

SHALL BE A SQUARE GRID, EQUAL IN BOTH DIRECTIONS. DOMES SHALL BE ALIGNED IN THE DIRECTION OF PEDESTRIAN TRAVEL AND DIRECTED TOWARD RAMP ON OPPOSITE SIDE OF STREET

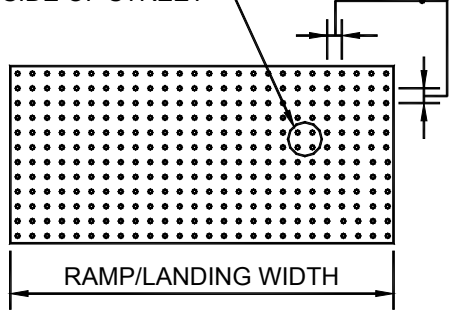

PLAN VIEW

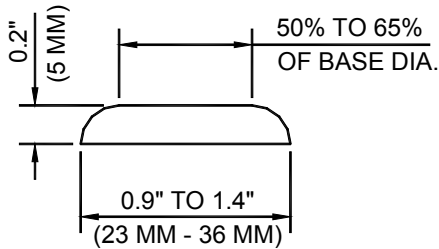

ELEVATION

**TRUNCATED DOME
DETECTABLE WARNING**

NOTE:
PAVERS WITH TRUNCATED DOMES SHALL VISUALLY CONTRAST WITH SURROUNDING PAVERS.

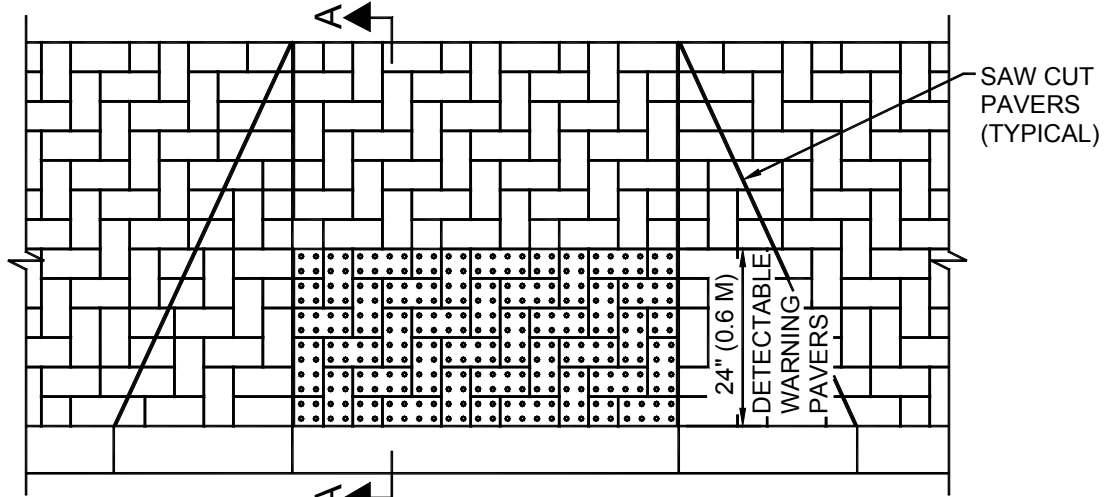

PLAN

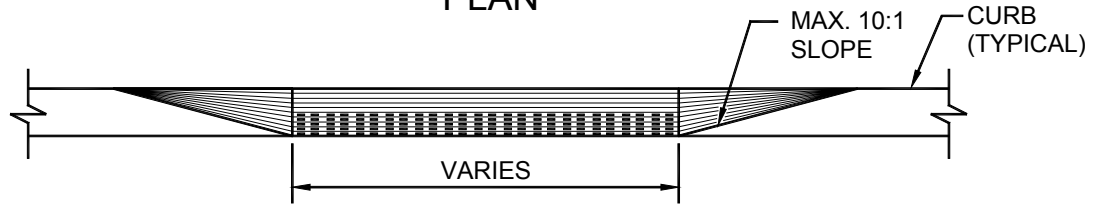

ELEVATION

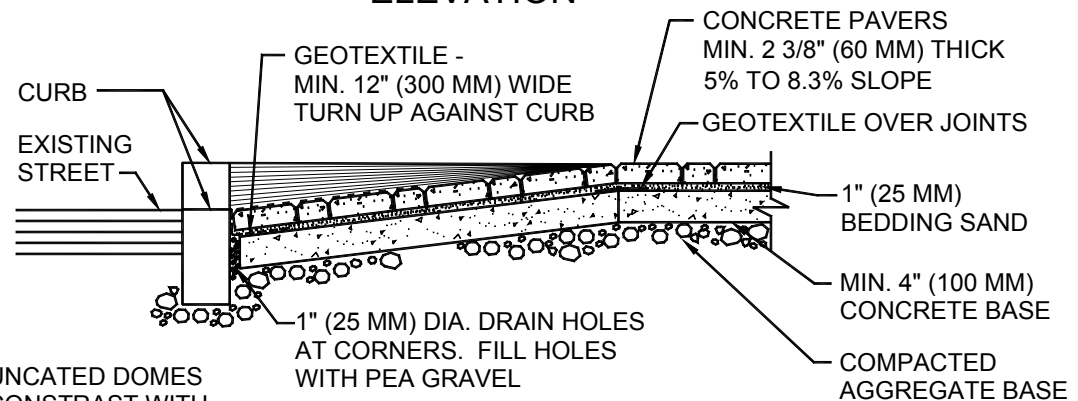

SECTION A-A

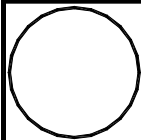

**CURB RAMP WITH
DETECTABLE WARNINGS**

DRAWING NO. ICPI-75

SCALE NO SCALE