

Provided By:



MULTI-WYTHER CONCRETE MASONRY WALLS

INTRODUCTION

Multiwythe masonry walls can take one of several forms: composite, noncomposite or veneer walls. The primary differences between these wall systems are in construction details and how applied loads are assumed to be carried and distributed through the loadbearing system.

In composite masonry, multiwythe masonry members act with composite action (refs. 1, 2). That is, composite walls are designed so that the wythes act together as a single structural member to resist loads. This requires that the masonry wythes be connected by masonry headers (which are rarely used due to cost and detailing restrictions) or by a mortar or grout-filled collar joint and wall ties to help ensure adequate load transfer between wythes.

In contrast, each wythe of a noncomposite masonry wall (also referred to as a cavity wall) is connected to the adjacent wythe with metal wall ties, but they are designed such that each wythe individually resists the loads imposed on it. Transverse bending moments (flexure), such as those due to wind, are distributed to each wythe in proportion to its relative stiffness. Loads acting parallel to the plane of a noncomposite wall (in-plane) are resisted only by the wythe on which the loads are applied, neglecting stress transfer between wythes.

In a veneer wall, the backup wythe is designed as the load-resisting system, with the veneer providing the architectural wall finish. The anchored veneer transfers all out-of-plane loads to the backup through wall ties, while supporting its own weight in-plane. Veneer walls are not covered in this TEK. Architectural detailing is covered in *Concrete Masonry Veneer Details*, TEK 05-10B (ref. 3). Prescriptive design and detailing requirements are included in *Concrete Masonry Veneers*, TEK 03-06C, and (ref. 4), while engineered design procedures are outlined in *Structural Design of Unreinforced Composite Masonry*, TEK 16-02B (ref. 5). Note that although *Building Code Requirements for Masonry Structures* defines a cavity wall as a noncomposite masonry wall, the term cavity wall is also commonly used to describe a veneer wall with masonry backup.

Although Building Code Requirements for Masonry Structures includes design provisions for noncomposite and composite

masonry walls, these design approaches are rarely taken with masonry walls, as they require two structural walls to be constructed adjacent to one another. In other words, if the structural design dictates the use of a 12-in. (305-mm) thick wall, it is often easier and more cost effective to use a single 12-in. (305-mm) wythe rather than a composite system consisting of 4-in. and 8-in. (102- and 203-mm) units. The primary advantage of using composite and noncomposite construction is in applications where different architectural features are desired on each side of a fully exposed concrete masonry wall. Greater flexibility in moisture control and insulation, as well as increased fire resistance rating and sound transmission class, can also be realized when compared to single wythe walls.

Information on the allowable stress design method, the strength design method and empirical design can be found in references 6, 7 and 8, respectively. The criteria specific to noncomposite and composite masonry walls are discussed in this TEK. Design tables are included in *Design of Concrete Masonry Noncomposite Walls*, TEK 16-04A, and *Structural Design of Unreinforced Composite Masonry*, TEK 16-02B (refs. 9, 10).

NONCOMPOSITE WALLS

In noncomposite construction, the wythes are connected by wall ties, as opposed to being rigidly bonded as in composite walls. The joint between wythes of noncomposite walls are not permitted to contain headers, grout or mortar.

With the exception of structural load paths and wall tie spacing requirements, architectural details for noncomposite masonry walls are nearly indistinguishable from those for masonry veneer on masonry backup. See *Concrete Masonry Veneer Details*, TEK 05-01B and *Concrete Masonry Veneers*, TEK 03-06C (refs. 3, 4).

Structural Design

Noncomposite walls are designed as follows: imposed vertical loads are carried by the wythe closest to the center of span of the supported member; bending moments are distributed to each wythe in proportion to its relative stiffness; and loads acting parallel to the plane of the wall (shear loads) are carried only by the wythe affected. In addition, the cavity width is limited to 4 ½ in. (114 mm) unless a detailed wall tie analysis is performed.

Transverse (out-of-plane) loads are distributed based on the wythe flexural stiffness as indicated by the moment of inertia, as follows:

$$W_i = w_T \left[\frac{E_m I_i}{E_m I_i + E_m I_o} \right] \quad W_o = w_T \left[\frac{E_m I_o}{E_m I_i + E_m I_o} \right]$$

Building Code Requirements for Masonry Structures includes prescriptive wall tie spacing requirements to aid compatible lateral deflection between wythes (see Figure 1). Wire wall ties, which may also include cross wires of horizontal joint reinforcement, are used to connect the wythes. Unless a detailed analysis is performed, the prescriptive requirements apply. In addition to the provisions shown in Figure 1, these prescriptive requirements include:

- Collar joints may not contain headers, grout, or mortar.
- Where the cross wires of joint reinforcement are used as ties, the joint reinforcement is required to be ladder-type or tab-type, as the truss-type restricts differential in-plane movement between the two wythes. Adjustable joint reinforcement assemblies are also permitted, and are considered to be a type of adjustable tie.
- Additional requirements for wall ties can be found in *Anchors and Ties for Masonry*, TEK 12-01B (ref. 11).

COMPOSITE WALLS

Composite walls are multiwythe walls where both wythes act structurally as one unit. They depend on sufficient stress transfer across the joint between wythes for composite action. In addition to the general design requirements to ensure sufficient structural capacity that are applicable to all structural masonry walls, *Building Code Requirements for Masonry*

Structures contains prescriptive requirements for bonding the wythes of composite walls as well as allowable shear stresses for the collar joint. While not prohibited by the code (ref. 2), wythes of composite masonry walls should not be constructed with dissimilar materials, such as clay and concrete masonry, as rigidly bonding such materials together does not permit differential movement between wythes.

Composite walls are most often designed with the axial load from floor slabs or the roof carried by the inner wythe of masonry. The vertical joint between wythes may contain either vertical or horizontal reinforcement, or reinforcement may be placed in either wythe. The thickness of the joint between adjacent wythes is not limited in thickness but is typically sized to accommodate modular layout and any reinforcement that may be placed in the joint. Stresses in each wythe due to axial load and flexure are calculated using the modular ratio, *n*, to transform sections using elastic analysis and assuming no slip at the collar joint, as shown in the following example.

Example: Reinforced Composite Wall Transformed Section and Neutral Axis

Consider a composite masonry wall constructed of 6-in. (152-mm) concrete masonry, a 2-in. (51-mm) grouted collar joint containing vertical No. 4 (M#13) bars at 48 in. (1,219 mm) on center, and 4-in. (102-mm) concrete brick. Moduli of elasticity for the materials are:

- concrete masonry: $E_m = 900 f'_m = 900(1,500 \text{ psi}) = 1,350,000 \text{ psi} (9,310 \text{ MPa})$
- grout: $E_g = 500 f'_g = 500(2,000 \text{ psi}) = 1,000,000 \text{ psi} (6,890 \text{ MPa})$
- steel: $E_s = 29,000,000 \text{ psi} (200 \text{ GPa})$

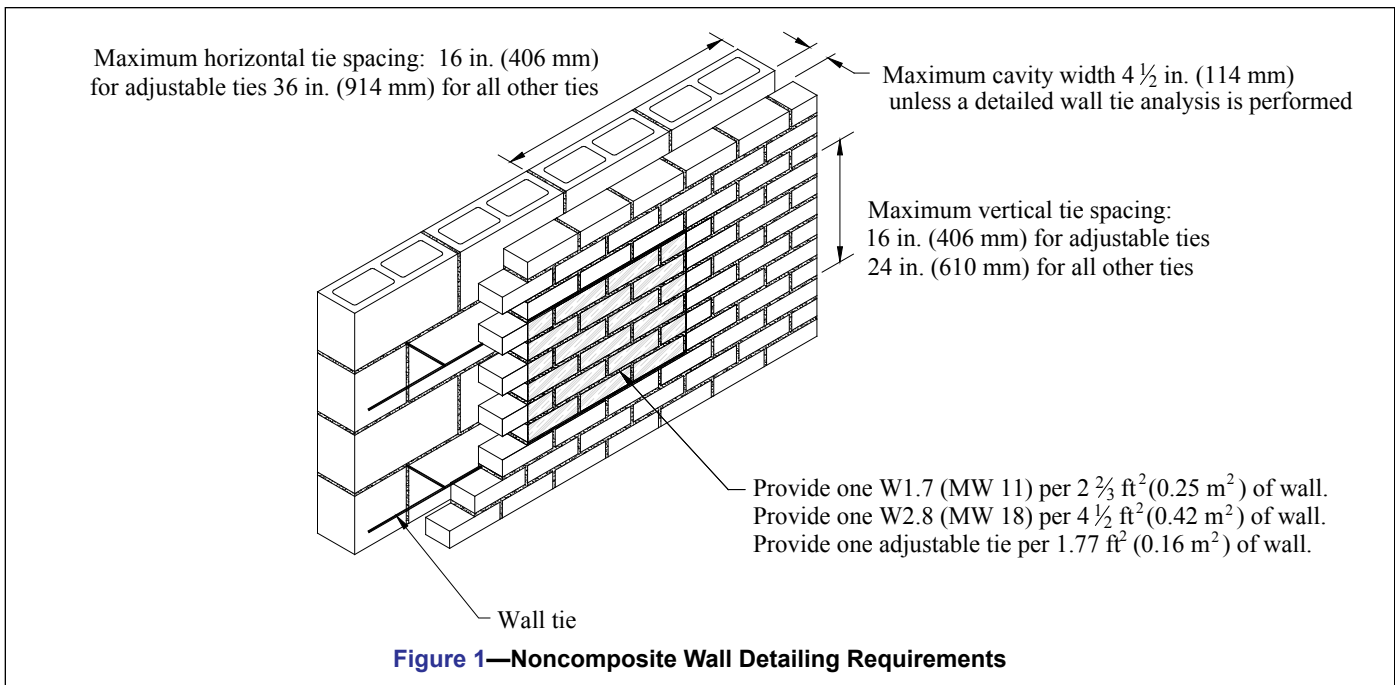

Figure 1—Noncomposite Wall Detailing Requirements

The modular ratio, n , for grout and steel are:

$$n_g = E_g / E_m = 1,000,000 / 1,350,000 = 0.74$$

$$n_s = E_s / E_m = 29,000,000 / 1,350,000 = 21.5$$

Using these modular ratios, equivalent areas of grout and steel based on a 12-in. (305-mm) width of concrete masonry are:

$$n_g A_g = 0.74 (2 \text{ in.} \times 12 \text{ in.}) = 17.8 \text{ in.}^2 (11,480 \text{ mm}^2)$$

$$n_s A_s = 21.5 (0.20 \text{ in.}^2/\text{bar} \times 0.25 \text{ bar}/\text{ft}) = 1.08 \text{ in.}^2 (697 \text{ mm}^2)$$

The resulting transformed section is shown in Figure 2.

The net cross-sectional areas of the 6-in. (152-mm) and 4-in. (102-mm) concrete masonry wythes are 24.0 in.²/ft (0.051 m²/m) and 43.5 in.²/ft (0.092 m²/m), respectively (ref. 12). Determine the total transformed area, A_{tr} :

$$A_{tr} = 24 + 17.8 + 1.08 + 43.5 \text{ in.}^2/\text{ft} \\ = 86.4 \text{ in.}^2/\text{ft} (0.18 \text{ m}^2/\text{m})$$

Next, determine the neutral axis location of the transformed section, by calculating \bar{x} , the distance from the neutral axis of the 6-in. (152-mm) concrete masonry to the neutral axis of the transformed section.

$$\bar{x} = \frac{\sum A_n x}{A_{tr}} = \frac{(17.8 \times 3.81) + (1.08 \times 3.81) + (43.5 \times 6.625)}{86.4} \\ = 4.17 \text{ in.} (106 \text{ mm})$$

Moments of inertia of the three wall elements are:

$$(I_{cm})_{6\text{-in.}} = 130.0 \text{ in.}^4/\text{ft} (1.78 \times 10^8 \text{ mm}^4/\text{m}) \text{ (ref. 12)}$$

$$I_g = (1/12) bh^3 = (1/12)(8.9)(2)^3 = 5.9 \text{ in.}^4/\text{ft} (8.10 \times 10^7 \text{ mm}^4/\text{m})$$

$$I_s = (1/12) bh^3 = (1/12)(2.2)(0.5)^3 = 0.023 \text{ in.}^4/\text{ft} (3.13 \times 10^4 \text{ mm}^4/\text{m})$$

$$(I_{cm})_{4\text{-in.}} = 47.6 \text{ in.}^4/\text{ft} (6.50 \times 10^7 \text{ mm}^4/\text{m}) \text{ (ref. 12)}$$

Using the parallel axis theorem, the moment of inertia of the transformed section, I_{tr} , is:

$$I_{tr} = \sum (I_o + Ad^2) \\ = [130.3 + (24)(4.17)^2] + [5.9 + (17.8)(4.17 - 3.81)^2] \\ + [0.023 + (1.08)(4.17 - 3.81)^2] \\ + [47.6 + (43.5)(6.625 - 4.17)^2] \\ = 865.8 \text{ in.}^4/\text{ft} (1.18 \times 10^9 \text{ mm}^4/\text{m})$$

Stresses in each element are then determined using: the transformed moment of inertia, I_{tr} ; the modular ratio, n ; the area of the transformed section, A_{tr} ; and the distance from the

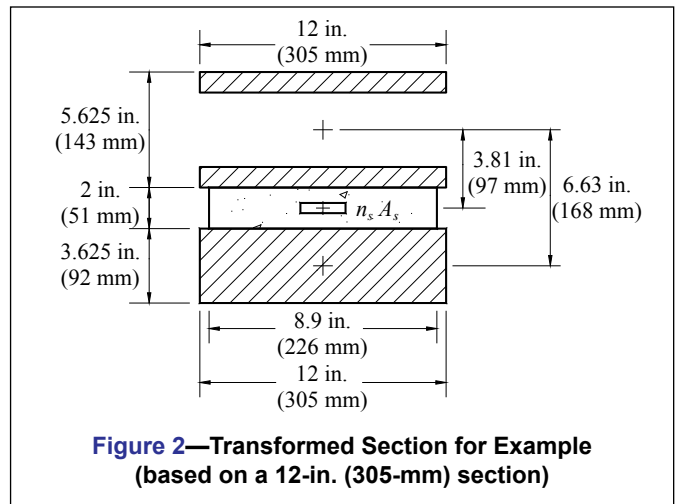

Figure 2—Transformed Section for Example (based on a 12-in. (305-mm) section)

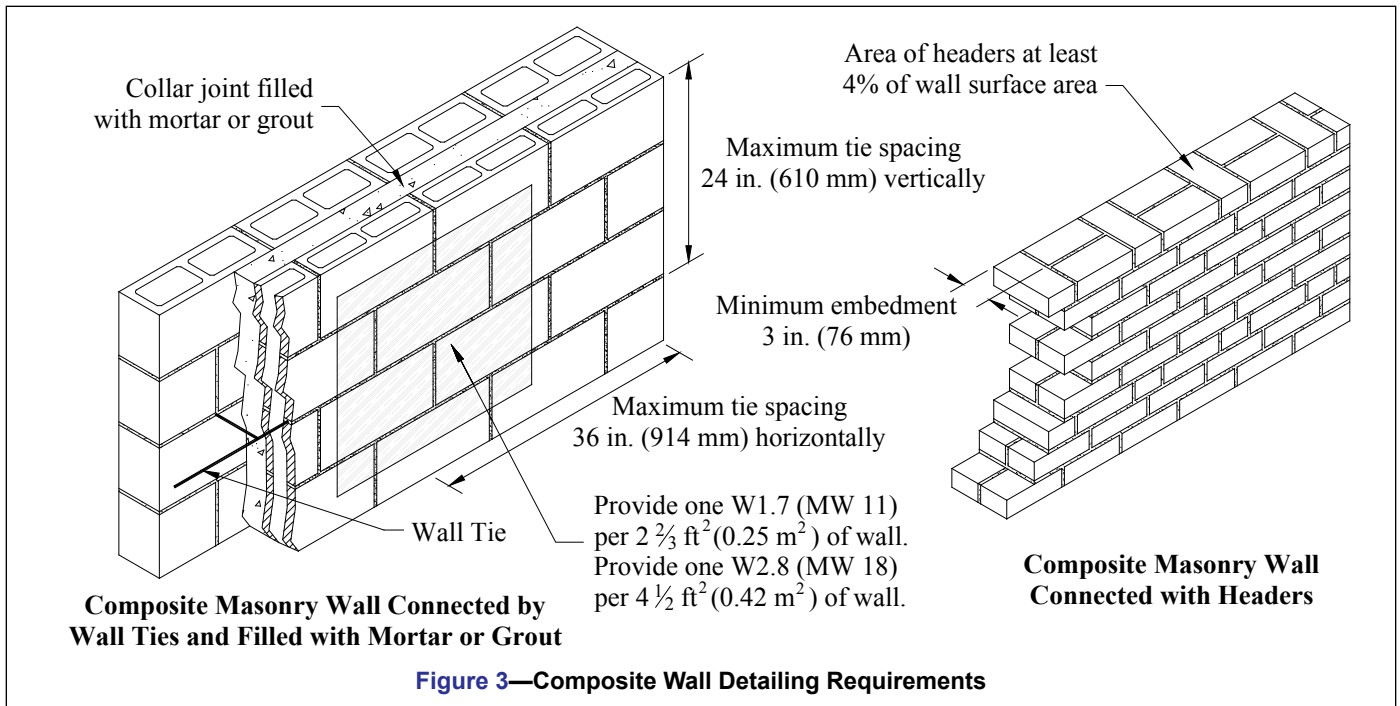

Figure 3—Composite Wall Detailing Requirements

extreme fiber to the neutral axis of the composite section, c . For example, the calculated tension in the steel due to flexure is:

$$f_s = n_s \frac{Mc_s}{I_{tr}}$$

Bonding the Wythes

To ensure shear transfer, *Building Code Requirements for Masonry Structures* requires that the joint between wythes either be filled with mortar or grout and connected by wall ties or be crossed by connecting masonry headers.

Wall tie spacing requirements are illustrated in Figure 3.

Although allowed, the use of masonry headers is an outdated method of connecting masonry wythes and is not recommended for several reasons. Headers are less ductile than metal wall ties, making accommodation for differential movement a critical issue. Differential movement can shear the headers, effectively eliminating the composite action, particularly with the combination of concrete masonry and clay masonry wythes. Also, walls bonded by headers are also more susceptible to water penetration

When headers are used, they must be uniformly spaced and have a total cross-sectional area not less than four percent of the total wall surface area. Headers are also required to be embedded at least 3 in. (76 mm) into each wythe. See Figure 3.

Construction Considerations

In composite masonry construction, insulation and vapor retarders, if required, can not be located in the joint between wythes, as is commonly done in noncomposite construction. Insulation can be located either in the cores of the inner wythe or on the wall interior.

Because the two wythes of a composite wall act as one structural unit, vertical movement joints, including fire-rated control joints, should extend through both wythes at the same location across the cavity joint.

NOTATIONS

- A_n = net cross-sectional area of a wall element, in.2/ft (mm²/m)
- A_{tr} = area of the transformed section, in.2/ft (mm²/m)
- c = the distance from the extreme fiber to the neutral axis of the composite section, in. (mm)
- d = distance from extreme compression fiber to centroid of tension reinforcement, in. (mm)
- E_g = modulus of elasticity of grout, psi (MPa)
- E_m = modulus of elasticity of masonry in compression, psi (MPa)
- E_s = modulus of elasticity of steel, psi (MPa)
- f'_g = specified compressive strength of grout, psi (MPa)
- f'_m = specified compressive strength of masonry, psi (MPa)
- f_s = calculated tensile or compressive stress in reinforcement, psi (MPa)
- I_{cm} = moment of inertia of concrete masonry, in.⁴/ft (mm⁴/m)
- I_g = moment of inertia of the grout, in.⁴/ft (mm⁴/m)
- I_s = moment of inertia of the steel, in.⁴/ft (mm⁴/m)
- I_i = average moment of inertia of inner wythe, in.⁴/ft (mm⁴/m)
- I_o = average moment of inertia of outer wythe, in.⁴/ft (mm⁴/m)
- I_{tr} = moment of inertia of transformed section, in.⁴/ft (mm⁴/m)
- M = maximum moment at the section under consideration, in-lb/ft (N-mm/m)
- n = modular ratio
- W_i = transverse load on inner wythe, psf (kPa)
- W_o = transverse load on outer wythe, psf (kPa)
- w_T = total transverse load, psf (kPa)
- x = distance from the neutral axis of an element to the neutral axis of the transformed section, in. (mm)
- \bar{x} = distance from the neutral axis of the 6-in. (152-mm) concrete masonry to the neutral axis of the transformed section, in. (mm)

REFERENCES

1. *International Building Code, 2003, With Commentary*. International Code Council, Inc., 2004.
2. *Building Code Requirements for Masonry Structures*, ACI 530-05/ASCE 5-05/TMS 402-05. Reported by the Masonry Standards Joint Committee, 2005.
3. *Concrete Masonry Veneer Details*, TEK 05-1B, Concrete Masonry & Hardscapes Association, 2003.
4. *Concrete Masonry Veneers*, TEK 03-06C, Concrete Masonry & Hardscapes Association, 2012.
5. *Structural Design of Unreinforced Composite Masonry*, TEK 16-02B, Concrete Masonry & Hardscapes Association, 2001.
6. *ASD of Concrete Masonry (2012 IBC & 2011 MSJC)*, TEK 14-7C, Concrete Masonry & Hardscapes Association, 2004.
7. *Strength Design Provisions for Concrete Masonry*, TEK 14-04B, Concrete Masonry & Hardscapes Association, 2008.
8. *Empirical Design of Concrete Masonry Walls*, TEK 14-08B, Concrete Masonry & Hardscapes Association, 2008.
9. *Design of Concrete Masonry Noncomposite Walls*, TEK 16-04A, Concrete Masonry & Hardscapes Association, 2004.
10. *Structural Design of Unreinforced Composite Masonry* TEK 16-02B, Concrete Masonry & Hardscapes Association, 2001.
11. *Anchors and Ties for Masonry*, TEK 12-01B, Concrete Masonry & Hardscapes Association, 2011.
12. *Weights and Section Properties of Concrete Masonry Assemblies*, CMU-TEC-002-23, Concrete Masonry & Hardscapes Association, 2023.

ABOUT CMHA

The Concrete Masonry & Hardscapes Association (CMHA) represents a unification of the Interlocking Concrete Pavement Institute (ICPI) and National Concrete Masonry Association (NCMA). CMHA is a trade association representing US and Canadian producers and suppliers in the concrete masonry and hardscape industry, as well as contractors of interlocking concrete pavement and segmental retaining walls. CMHA is the authority for segmental concrete products and systems, which are the best value and preferred choice for resilient pavement, structures, and living spaces. CMHA is dedicated to the advancement of these building systems through research, promotion, education, and the development of manufacturing guides, design codes and resources, testing standards, and construction practices.

Disclaimer:

The content of this CMHA Tech Note is intended for use only as a guideline and is made available "as is." It is not intended for use or reliance upon as an industry standard, certification or as a specification. CMHA and those companies disseminating the technical information contained in the Tech Note make no promises, representations or warranties of any kind, expressed or implied, as to the accuracy or completeness of content contained in the Tech Note and disclaim any liability for damages or injuries resulting from the use or reliance upon the content of Tech Note. Professional assistance should be sought with respect to the design, specifications, and construction of each project.