

Provided By:



## STRATEGIES FOR TERMITE RESISTANCE

### INTRODUCTION

Termites are distributed widely throughout the United States, causing substantial damage to unprotected wood buildings. Although there are over forty species of termites in the United States alone (over 2,500 species around the world), most termite damage is attributed to subterranean termites. Recently, much attention and concern has been directed to the relative newcomer, the very aggressive Formosan termite, found mainly in the southern states and Hawaii, but is dramatically increasing in numbers and spreading toward the northern states. In Southern Louisiana the population is estimated to have increased more than 3,000% in the past ten years alone.

Concrete masonry is one of the best products available for termite resistance since it does not provide a source of nutrition. Entire structures can be constructed of concrete and masonry materials, virtually eliminating the possibility of damage from termites. This includes a composite block/steel bar joist floor system that is immune to termite attack (ref. 2).

This TEK focuses on measures to reduce the possibility of subterranean termite entry into a building. While termites do not cause any damage to masonry materials, they do feed on any products containing cellulose, most notably wood. Buildings that do not use wood or cellulose products as a construction material are not prone to termite infestation making concrete masonry the perfect application for both above and below grade construction. Concrete masonry is very versatile with an almost endless array of architectural

shapes, sizes textures and colors available. When wood is used as a construction material, the further the food source is from the soil, the lower the likelihood of termite infestation such as the traditional wood roof framing.

Subterranean termites nest in the ground because they require a moist, humid environment to survive. Entry into a building must be gained through a sheltered path, such as a crack in a foundation wall or slab. If a sheltered path to the food source is not available, it is possible for termites to build their own access

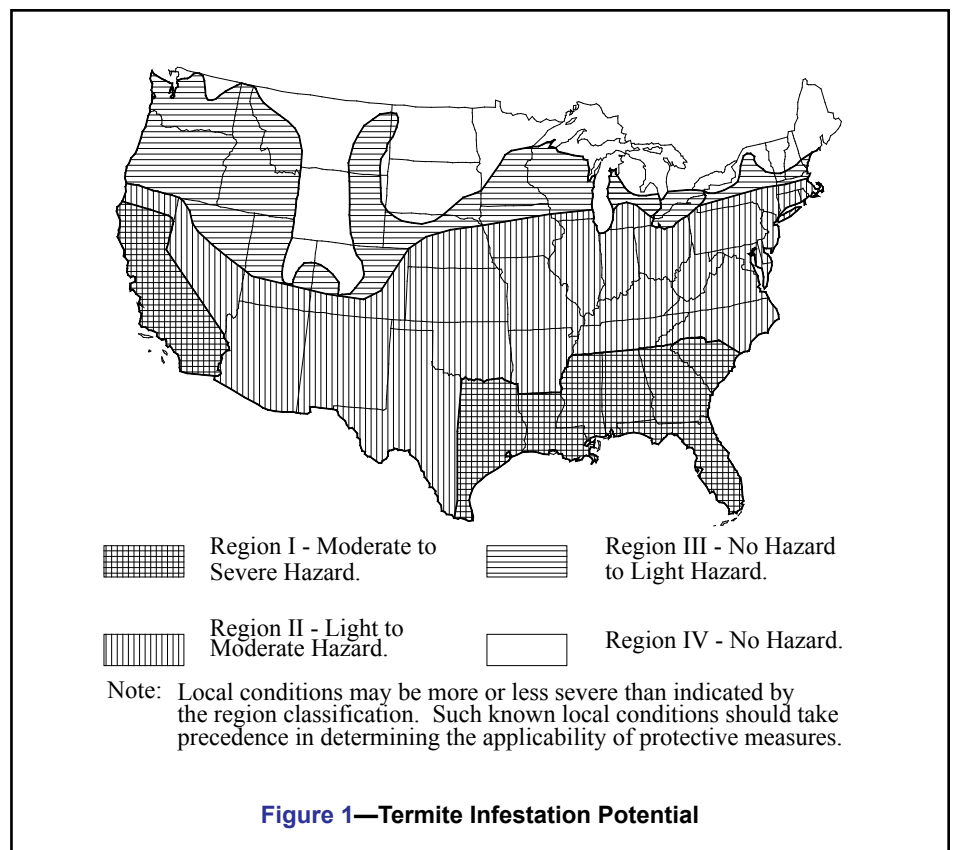

Figure 1—Termite Infestation Potential

tunnels, which protect them from sunlight and open air. Often, these access tunnels can be the only direct sign of a termite infestation.

It is important to consider the potential for termite infestation during the construction phase since the building construction practices themselves can help protect against future infestation. Many of these measures focus on proper design and quality construction to reduce possible entry routes and to provide a hostile (that is, dry) environment to ward off termites. These same methods may already be employed for protection from water penetration or soil gas entry.

Strategies for termite control include:

- building out of all concrete masonry;
- minimizing cracks in walls and slabs;
- sealing around all wall and floor penetrations;
- adequate drainage around the foundation and adjacent soil;
- providing access to inspect for termite tunnels;
- installing barriers to prevent termite entry;
- maintaining a minimum clearance between wood members and soil;
- treating soil with chemicals to repel termites; and
- utilizing termite resistant construction materials.

The level of termite control employed on a particular job should be consistent with the expected severity of the termite hazard. This level of severity for a particular location can be determined from local experience or from the state entomological authorities. Where such information is not available, Figure 1 may serve as a guide.

**SITE CONDITIONS**

While preparing the site prior to construction, all roots, stumps, dead timber, and other wood debris should be removed from the site. Similarly, wood scraps from construction should be properly disposed. Leaving this material on site or in the backfill provides additional food sources for termites, attracting them and increasing the likelihood of infestation. Similarly, wood grade stakes or bracing stakes should be removed before or during a concrete placement and not be cast into the concrete. Leaving them in place attracts termites and provides a direct path for them through the concrete. Refer to Figure 2 for a summary of critical termite access areas.

Backfilling with a free draining soil, incorporating a subgrade drainage system, and installing proper above-grade water drainage will help keep the foundation and adjacent soil dry, providing a less hospitable environment for termites.

In extreme circumstances, subterranean termites may not require constant access to and from the adjacent soil. Where conditions exist such that wood remains continuously wet, termites do not need to return to the soil to obtain water. However, such conditions are rare if proper design and construction for water penetration resistance are adhered to.

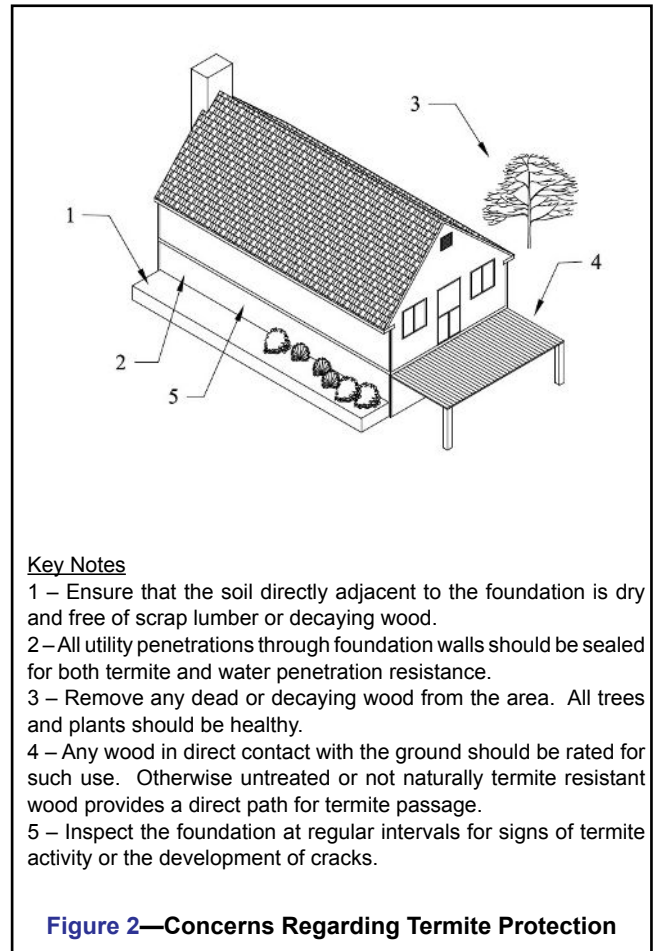

**REDUCING ENTRY ROUTES**

Once the termites have established a path, they have unimpeded access to the entire structure. Therefore, keeping termites out of the structure should always be the paramount objective. In addition to the obvious points of entry, such as wood in direct contact with the soil, other obscure (but critical) termite entry routes include:

- through cracks in exposed wall faces or slabs. Termites are capable of moving through a crack only 1/32 inch (0.79 mm) wide;
- direct access from soil under porches or patio slabs;
- along the outside of pipes penetrating slabs or foundation walls; and
- access tunnels on the interior or exterior of walls.

**MINIMUM CLEARANCE TO SOIL**

It is desirable to keep wood elements as far as possible from the soil to minimize termite access. Nonstructural wood elements, such as wood siding and trim, should be kept a minimum of 6 inches (152 mm) from the soil surface. Structural wood framing, sill plates, and sheathing should be kept at least 8 inches (203

mm) above the soil, or as otherwise required by local building codes. However, if the nonstructural wood is in contact with the structural wood (which is generally the case), the 6 inch (152 mm) minimum clearance should be increased to 8 inches (203 mm). These general clearances do not apply to pressure-treated wood or other termite and decay resistant woods.

## MINIMIZING CRACKS

Proper structural design of foundation walls, footings, and slabs will help prevent structural cracking that may allow termite entry. In addition to preventing cracks due to structural overload, cracking due to concrete shrinkage also needs to be addressed. Due to fluctuations in the temperature and moisture content, all materials have a tendency to expand and contract over time. With concrete masonry foundations, the primary concern focuses on shrinkage resulting in the development of tensile stresses. This is because the tensile strength of concrete is relatively small compared to the compressive strength; therefore shrinkage may result in small cracks within the masonry.

It is normally not necessary to provide control joints in below grade residential concrete masonry basement walls. A control joint is a planned joint in a concrete masonry wall at regular intervals that accommodates shrinkage movement without unsightly, random cracking. The lack of a need for control joints is attributed to the relatively low range of thermal and moisture fluctuations occurring in below grade walls afforded by the soil adjacent to the walls and to the water resistant systems applied to basement walls. In most below grade basement wall construction, it is possible to provide a reinforced bond beam at or near the top of the wall in lieu of control joints to minimize crack development. The bond beam also provides a cap, preventing termites from coming up through the empty cores of ungrouted block and gaining entry into the building. Joint reinforcement embedded in the horizontal bed joints, usually at 16 inches on center, also provides additional tensile strength for the masonry and aids in crack control. It should be pointed out that horizontal reinforcement will not completely eliminate cracking, but it will hold the cracks so tightly together that the termites cannot get through.

Additional measures to reduce the shrinkage cracking potential of concrete masonry include keeping the walls dry during construction. Because drying shrinkage is a primary cause of cracking in concrete masonry walls, it is important to minimize the potential for wetting concrete masonry during the construction process. At the jobsite, concrete block should be stored so as to protect the units from absorbing ground water or precipitation. This includes storing block on pallets (or otherwise isolating block from direct contact with the ground) and covering the units with plastic or other water-repellent materials.

Concrete masonry units should be dry when laid. Some surface moisture is acceptable; however, saturated units should be allowed to dry out before placement in the wall. Concrete masonry units should never be wetted before or during placement in the wall, as may be customary with other types of masonry units.

At the end of each workday, a weatherproof membrane should be placed over uncompleted walls to protect the units from rain or snow. Placing a board on top of the membrane will help hold it in place and will prevent the membrane from sagging into the masonry cores and allowing water to collect. To limit concrete slab cracking, the recommendations of the American Concrete Institute (ref. 5) for quality concrete placement should be followed.

In basement walls, the dampproofing and waterproofing measures employed to reduce water penetration aid in the prevention of termite entry. Waterproofing and dampproofing systems require that the barrier be continuous to prevent water penetration into voids or open seams. Similarly, the barrier is typically carried above the finished grade level to prevent water entry between the barrier and the foundation wall. Cracks exceeding 0.02 inches (0.5 mm) should be repaired before applying a waterproof or damp-proof barrier. However, the repair of hairline cracks is typically not required, as most barriers will either fill or span these small openings. In addition, waterproofing and dampproofing systems should be applied to clean dry walls. In all cases, manufacturer's directions should be carefully followed for proper installation.

Particular attention should be paid to reentrant corners at garages, porches, and fireplaces and to wall penetrations. Because stress concentrations develop at these intersections, pliable membranes and/or additional reinforcement are often recommended at these locations to span any potential cracks or hold them tightly together.

Typical water penetration measures include coatings, sheet membranes, and drainage boards. Coatings are sprayed, trowelled, or brushed onto below-grade walls, providing a continuous barrier to water entry. Coatings should be applied to clean, structurally sound walls. Walls should be brushed or washed to remove dirt, oil, efflorescence, or other materials that may reduce the bond between the coating and the wall.

Sheet membranes and panels (drainage boards) are less dependent on workmanship and on surface preparation than coatings. Many of the membrane systems are better able to remain intact in the event of settlement or other movement of the foundation wall. All seams, terminations, and penetrations must be properly sealed. Care must also be exercised during the backfilling process to ensure that the barrier is not damaged.

In crawl space and stem walls, which typically are not treated on the exterior to prevent water entry as basement walls are, crack control measures become more important. In these cases, termites can enter the block through small cracks and move unseen up ungrouted cores. In these instances, solid grouting or capping of the walls is recommended.

## CAPPING CONCRETE MASONRY WALLS

Various methods are used to seal the tops of masonry foundation walls. Should termites penetrate the face shell of a concrete masonry wall below, the cap prevents them from direct access to the wood superstructure. In reinforced construction, the masonry bond beam at the top of the wall serves as an effective cap, as shown in Figure 3.

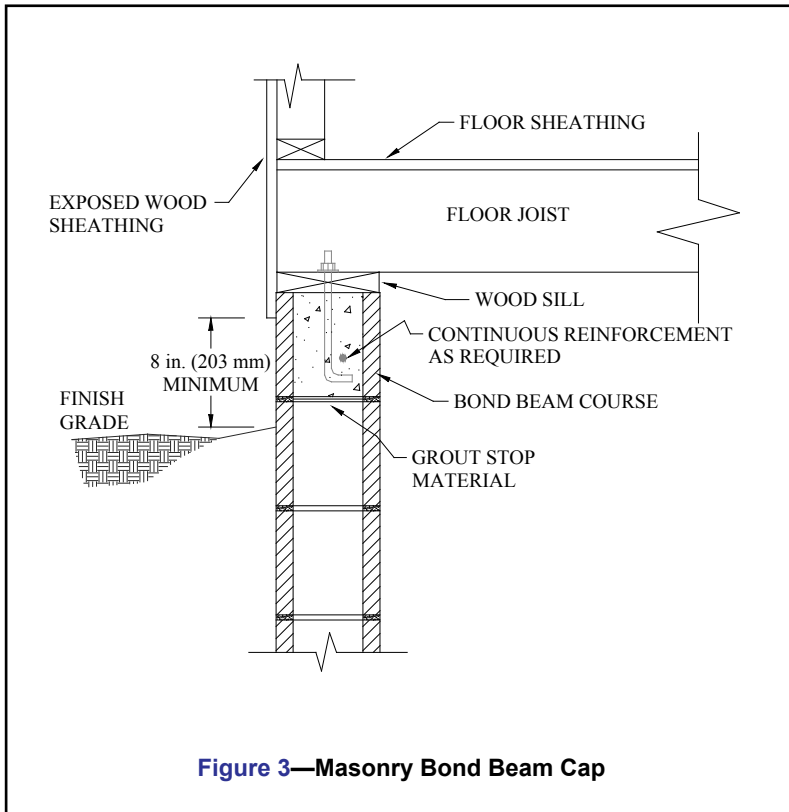

Figure 3—Masonry Bond Beam Cap

Bond beam units are specifically designed to accommodate horizontal reinforcement and grout as shown in Figure 4. Bond beam units can be either solid bottom or open bottom. The latter requires a screen grout stop or expanded metal to contain the grout within the unit. A reinforced bond beam is preferred to solid units or solid bottom units with solid head joints since the reinforcement in bond beams will hold any cracks that form tightly together to prevent termite entry through the cracks.

Proper grouting procedures are important to ensure bond with the masonry units and void free areas in bond beams and cells

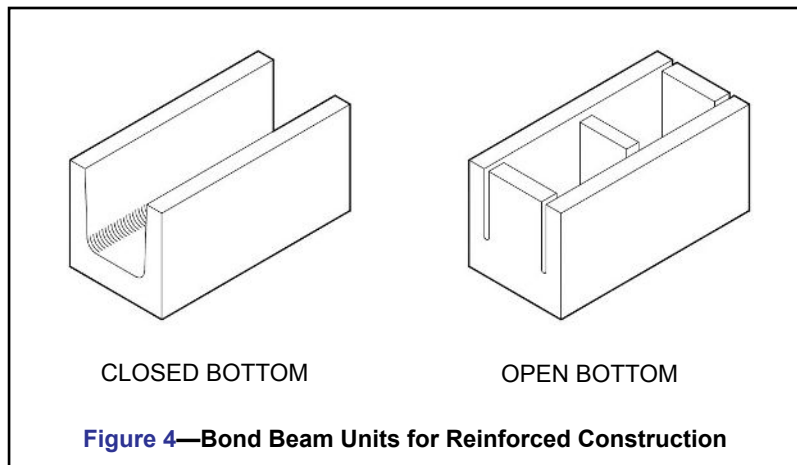

Figure 4—Bond Beam Units for Reinforced Construction

to be filled. Grout should conform to the *Specification for Grout for Masonry*, ASTM C 476 (ref. 7) or be specified to have a minimum compressive strength of 2,000 psi (13.8 MPa) at 28 days in accordance with the *Specification for Masonry Structures*, ACI 530.1/ASCE 6/TMS 402 (ref. 6). The Specification also requires enough water in the grout mixture to achieve a slump of 8 to 11 inches (203 to 279 mm) (ref. 6, 4) when tested in accordance with ASTM C 143 *Standard Test Method for Slump of Hydraulic Cement Concrete* (ref. 9). See Figure 5.

This high slump is contrary to the principles of cast-in-place concrete where high slump levels lead to reduced strengths and higher shrinkage. Many engineers mistakenly try to apply this same analogy to masonry – lowering the water content in an effort to reduce shrinkage potential. However, **in masonry construction, the high slump is critical** as it allows the grout to be fluid enough to flow around reinforcement and completely fill all the voids (ref. 3, 4, and 6). The initial high water-to-cement ratio is reduced significantly as the masonry units absorb the excess water, resulting in higher strengths and low shrinkage properties despite the high initial water-to-cement ratio. Additionally, as the excess water is absorbed into the masonry units, some of the cement is drawn into the unit with the water creating excellent bond and reducing the formation of voids.

Grout should also be placed in lifts not exceeding 5 ft. (ref. 6). A lift is the layer of grout placed in a single continuous operation. Additionally, each lift should be consolidated with either a  $3/4$  in. (19 mm) diameter low velocity vibrator. Consolidation eliminates voids, helping to ensure complete grout fill and good bond with the masonry units. After the water is absorbed from the grout mixture into the masonry (normally 3 to 10 minutes after placement, depending on the absorption characteristics of the unit and weather conditions), the grout should be reconsolidated to close the space left by the excess water that was absorbed (ref. 3). In any case, reconsolidation must be completed before the grout loses its plasticity.

Metal termite shields may be installed as a continuous barrier directly below the sill plate. If infestation occurs, termites are forced to build conspicuous access tunnels around the shield, making detection easy. Because termites require only a  $1/32$  inch (0.79 mm) gap for penetration, termite shields must be installed with great care to be effective. All seams must be soldered and all openings around anchor bolts and service leads must be sealed. Because of the extreme care required to provide an impenetrable metal termite shield, they generally are not to be relied on for termite protection.

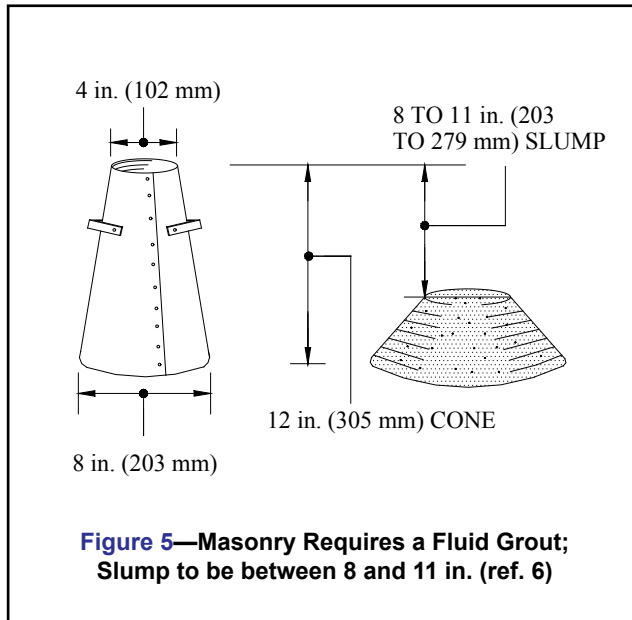

**Figure 5—Masonry Requires a Fluid Grout; Slump to be between 8 and 11 in. (ref. 6)**

### EXTERIOR INSULATION

The rigid plastic foams that are often used to insulate crawl space and the exterior side of basement walls can allow termites to create undetectable tunnels and is prohibited for such use by some codes (ref. 7). An advantage of concrete masonry foundation walls is their ability to accommodate insulation within the cores of the masonry units where it is protected from direct contact with the soil. Either rigid foam insulation inserts, granular fill insulation, or foamed-in-place insulation can be used for this purpose.

### ADDITIONAL CONSIDERATIONS FOR CRAWL SPACES

Figure 6 illustrates termite control measures for crawl space foundations. Crawl space floors should be kept at or above the exterior finished grade to facilitate drainage in the crawl space. Where this is not possible, or on sites where water flows toward the building due to the site slope, area drains should be installed. Unless specified otherwise by local codes, wood girders should be at least 12 inches (305 mm) above the crawl space floor, and wood joists should be no closer than 18 inches (457 mm) to the soil. In all cases, enough clearance should be maintained to allow access to the crawl space for inspection.

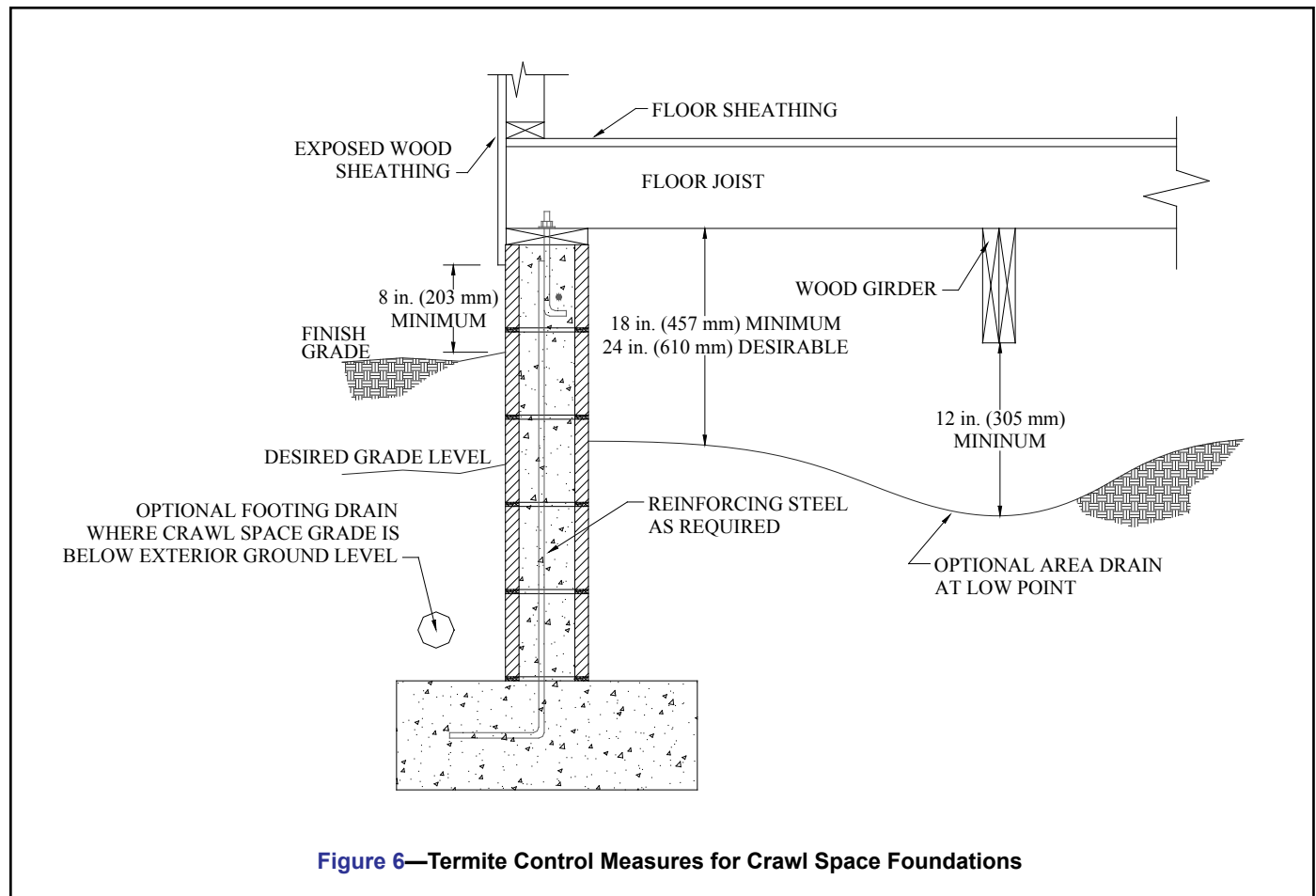

**Figure 6—Termite Control Measures for Crawl Space Foundations**

## CHEMICAL TREATMENTS

Numerous methods are available to create a pesticide barrier within the soil adjacent to a structure to prevent termite entry. Soil treatment before or during construction is often most effective as there is better access to the subgrade soil. If a slab-on-grade is also going to be used, the soil under the slab can also be pretreated. While post-construction treatment is far more common, it is also more difficult. Limited access to some areas may not allow for an effective chemical barrier to be established.

## REFERENCES

1. *Basement Manual: Design and Construction Using Concrete Masonry*, CMU-MAN-002-01, Concrete Masonry & Hardscapes Association, 2001.
2. *Concrete Masonry Homes: Recommended Practices*. U.S. Department of Housing and Urban Development, Office of Policy Development and Research, 1999.
3. *Grouting Concrete Masonry Walls*, CMHA TEK 03-02A, Concrete Masonry & Hardscapes Association, 2005.
4. *Grout for Concrete Masonry*, CMHA TEK 09-04A, Concrete Masonry & Hardscapes Association, 2005.
5. *Guide to Residential Cast-In-Place Concrete Construction*, ACI 332-84. American Concrete Institute, 1984.
6. *Specification for Masonry Structures*, ACI 530.1-99/ASCE 6-99/TMS 602-99. Reported by the Masonry Standards Joint Committee, 1999.
7. *Standard Building Code*. Southern Building Code Congress International, 1999: 2304.1.4.
8. *Standard Specification for Grout for Masonry*, ASTM C 476-99. American Society for Testing and Materials, 1999.
9. *Standard Test Method for Slump of Hydraulic Concrete, ASTM C 143/C 143M*. American Society for Testing and Materials, 1998

## CONCLUSION

Concrete masonry is an ideal construction material to resist termites. It does not provide food to attract them, and provides a barrier to prevent termite entry. It is also very versatile with an almost endless amount of architectural shapes, sizes, textures, and colors available. An innovative, totally termite proof concrete masonry floor system utilizing a hidden steel bar joist supporting system is also available.

## ABOUT CMHA

The Concrete Masonry & Hardscapes Association (CMHA) represents a unification of the Interlocking Concrete Pavement Institute (ICPI) and National Concrete Masonry Association (NCMA). CMHA is a trade association representing US and Canadian producers and suppliers in the concrete masonry and hardscape industry, as well as contractors of interlocking concrete pavement and segmental retaining walls. CMHA is the authority for segmental concrete products and systems, which are the best value and preferred choice for resilient pavement, structures, and living spaces. CMHA is dedicated to the advancement of these building systems through research, promotion, education, and the development of manufacturing guides, design codes and resources, testing standards, and construction practices.

### Disclaimer:

The content of this CMHA Tech Note is intended for use only as a guideline and is made available "as is." It is not intended for use or reliance upon as an industry standard, certification or as a specification. CMHA and those companies disseminating the technical information contained in the Tech Note make no promises, representations or warranties of any kind, expressed or implied, as to the accuracy or completeness of content contained in the Tech Note and disclaim any liability for damages or injuries resulting from the use or reliance upon the content of Tech Note. Professional assistance should be sought with respect to the design, specifications, and construction of each project.