

Provided By:



SAMPLING AND TESTING SEGMENTAL RETAINING WALL UNITS

INTRODUCTION

Segmental retaining wall (SRW) units are subject to the minimum requirements of *Standard Specification for Dry-Cast Segmental Retaining Wall Units*, ASTM C1372 (ref. 1). This standard includes criteria for minimum compressive strength, maximum water absorption, maximum permissible variations in dimensions, and, when required, freeze-thaw durability. Test methods used to demonstrate compliance with these requirements are outlined in this Tech Note.

SAMPLING SEGMENTAL RETAINING WALL UNITS

Segmental retaining wall units are sampled using the same procedures as used for other concrete masonry units. The purpose of selecting multiple test specimens for unit testing is to ensure that the range of results is representative of the entire lot of units from which the specimens were taken. Selecting units from only one portion of a pallet, or choosing only the most or least desirable units may misrepresent the properties of the lot.

Selected specimens should be randomly chosen from each lot, and should all have similar unit configurations and dimensions. A minimum of three units are required to be sampled for compression, absorption and dimensional evaluation in accordance with ASTM C140/C140M, *Standard Test Method for Sampling and Testing Concrete Masonry Units and Related Units* (ref. 2). When freeze-thaw durability testing is also performed, a total of five units should be selected. Since testing for compressive strength, absorption, and freeze-thaw are performed on coupon specimens, all tests can be performed on each sampled unit. Each test specimen

is marked with a unique identification, which makes the test specimen immediately identifiable at any point during the testing. Immediately after marking, each unit is weighed to determine the received weight. Note that any loose material should be removed prior to weighing.

MEASUREMENT OF DIMENSIONS

Unit dimensions are measured to verify that the overall length, width and height are within the allowable $\pm 1/8$ in. (3.2 mm) tolerances permitted by ASTM C1372. This tolerance does not apply to architectural surfaces, such as split faces.

For each unit, the overall width is measured at the mid-length of the unit across the top and bottom bearing surfaces of the unit using a steel scale marked with $1/10$ -in. (2.5-mm) divisions (or smaller). Similarly, the overall length is measured at the mid-height at the front and back of each specimen. For height, six total measurements are taken. Four of these measurements are at each corner of the specimen, and the remaining two are taken at mid-length of the front and back of the unit (See Figure 1). The reported overall dimensions are determined by

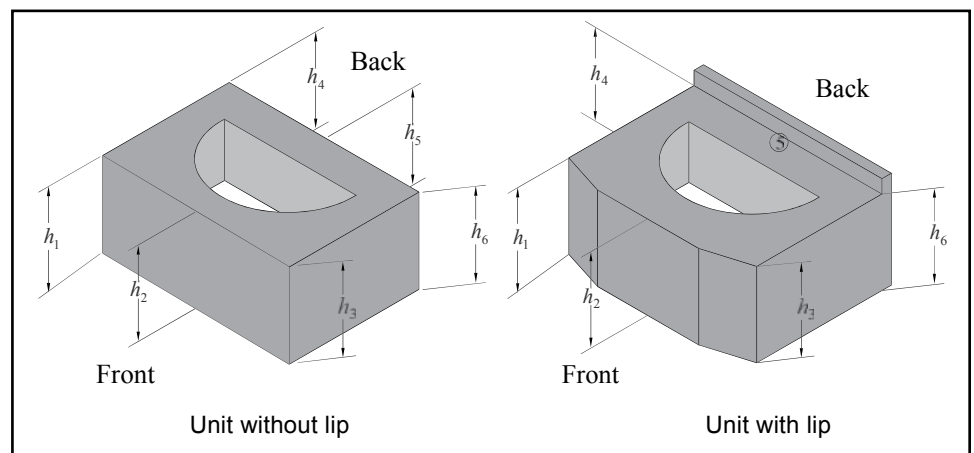

Figure 1—Height Measurements for SRW Units (ref. 2)

averaging the respective measurements for width and height, and reporting the front and back length of the unit separately.

Additional dimensional and testing information can be found in *Segmental Retaining Wall Units*, SRW-TEC-001-15 (ref. 3).

ABSORPTION TESTING

Absorption describes the amount of water a unit can hold when saturated. Absorption can be an indicator of the level of compaction of the concrete mix, the aggregate gradation, and the volume of voids within a unit. Data collected during absorption testing is used to calculate absorption and density. During absorption testing, the weight of each specimen is determined in the following order and condition: received weight; immersed weight; saturated weight; and oven-dry weight. The immersed and saturated weights are determined following 24 to 28 hours of immersion in water and prior to oven drying the specimens.

ASTM C140/C140M allows for absorption testing of either full units or coupons. Because of the size and weight of SRW units, coupon specimens are typically tested in lieu of full size units. When reduced-size unit are used for absorption testing, the reduced-size specimen must have an initial weight of at least 20% of the full-size unit weight. This is intended to ensure that a sufficiently sized specimen is tested in order for the results to be representative of the entire unit.

The absorption specimens are immersed in water with a temperature between 60 and 80°F (15.6 to 26.7°C) for 24 to 28 hours, and each specimen is weighed while suspended and completely submerged in water to determine the immersed weight. After determining the immersed weight, the units are removed from the tank and allowed to drain for 60 ± 5 seconds by placing them on a 3/8-in. (9.5-mm) or coarser wire mesh. A damp cloth is used to remove surface water, since a dry cloth may absorb water from the masonry unit. Each unit is weighed again to determine the saturated weight.

Testing larger specimens for absorption requires particular attention to drying times, because it takes a greater length of time to remove all of the moisture from larger masses. To reach an oven-dry condition, the units must be dried for at least 24 hours in a ventilated oven at a temperature of 221 to 239°F (105 to 115°C). For most laboratories, this means a drying time of more than 24 hours, since several hours are typically required to raise the oven temperature to the specified range after the room-temperature SRW units are inserted.

Table 1—Maximum Water Absorption for SRW Units (ref. 1)

Unit weight classification ^a :	Lightweight < 105 pcf (< 1,682 kg/m ³)	Medium weight 105 to < 125 (1,682 to < 2,002 kg/m ³)	Normal weight ≥ 125 pcf (≥ 2,002 kg/m ³)
Max. absorption, lb/ft ³ (kg/m ³):	18 (288)	15 (240)	13 (208)

^a Based on oven-dry density of concrete.

After at least 24 hours, unit weights are recorded in two-hour intervals to ensure the units are no longer losing weight due to moisture loss. The unit is considered oven dry when two successive weighings differ by 0.2% or less. Note that when weighing the units using an electronic scale, insulating materials for the scale may be necessary, because heat radiating from a unit just removed from the oven may cause the scale to return inaccurate results.

ASTM C1372 (ref. 1) includes the maximum water absorption requirements shown in Table 1.

COMPRESSIVE STRENGTH TESTING

Compressive strength tests are used to ensure that the SRW units meet the minimum strength requirements of ASTM C1372: minimum net average compressive strength of 3,000 psi (20.7 MPa) for an average of three units with no individual unit less than 2,500 psi (17.2 MPa).

Some critical areas of compression testing that are necessary to ensure accurate testing include:

- appropriate capping stations with stiff, planar plates with smooth surfaces,
- compression machines with spherically seated heads and bearing plates meeting the requirements of ASTM C140/C140M (ref. 2), and
- proper specimen alignment within the testing machine (specimen’s center of mass aligned with machine’s center of thrust).

ASTM C140/C140M testing procedures for compressive strength of SRW units are the same as those for conventional concrete masonry units (see TEK 18-07, ref. 4), with the exception that coupons are tested in lieu of full-size units.

The tested compressive strength can be influenced by the size and shape of the specimen tested and the location where the coupon was taken. For these reasons, it is important that all retaining wall units be tested using a similar size and

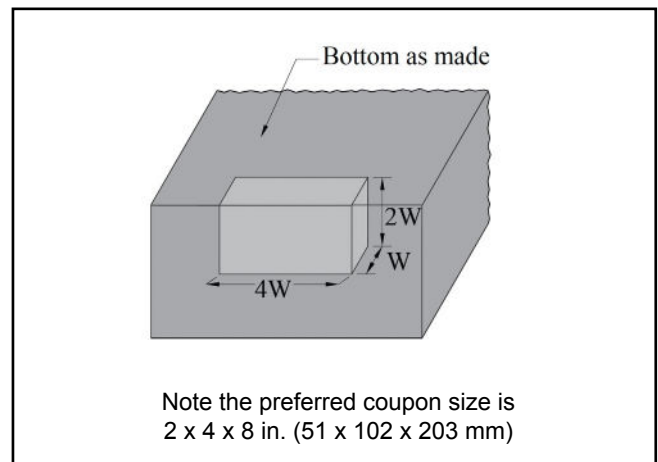

Figure 2—SRW Coupon for Compressive Strength Testing

shape specimen. In addition, the SRW unit supplier should be contacted for the recommended coupon sample location. Proper equipment and procedures are essential to prevent damaging the test specimen as a result of saw-cutting. Water-cooled, diamond-tipped blades on a masonry table saw are recommended. The blade should ideally have a diameter large enough to make each required cut in a single pass.

ASTM C140/C140M requires coupons to have a height to thickness ratio of 2:1 before capping and a length to thickness ratio of 4:1 (see Figure 2). The coupon width must be as close to 2 in. (51 mm) as possible based on the configuration of the unit but not less than 1.5 in. (38 mm). The preferred size is 2 x 4 x 8 in. (51 x 102 x 203 mm) (width x height x length). Coupon dimensions must be within 1/8 in. (3 mm) of the targeted dimensions. The coupon height is taken to be in the same direction as the unit height dimension. If these procedures are followed, the compressive strength of the coupon is considered to be the same as the strength of the whole unit.

FREEZE-THAW DURABILITY

In areas where the segmental retaining wall is likely to be exposed to repeated freezing and thawing under saturated conditions, ASTM C1372 requires that freeze-thaw durability be demonstrated in one of the following ways:

1. proven field performance,
2. each of five specimens must have less than 1% weight loss after 100 cycles, or
3. four of five specimens must each have less than 1.5% weight loss after 150 cycles.

When required, testing is in accordance with ASTM C1262, *Standard Test Method for Evaluating the Freeze-Thaw Durability of Dry-Cast Segmental Retaining Wall Units and Related Concrete Units* (ref. 5), an accelerated laboratory test that provides an indication of relative performance when the units are placed in service. Testing in accordance with ASTM C1262 can be conducted using water or saline (3% sodium chloride by weight) as the test solution. ASTM C1372, however, does not require freeze-thaw evaluation in saline, recognizing that

for most applications tests in water are considered sufficient. If the units are to be exposed to deicing salts on a regular basis, local project specifications should be consulted to determine if testing in saline is required.

Freeze-thaw durability test methods are prescribed because freeze-thaw durability cannot be reliably predicted based on factors such as compressive strength, absorption or concrete density. A unit’s freeze-thaw durability can be influenced by manufacturing variables such as:

- aggregate type,
- production methods,
- cement content and
- presence of admixtures; as well as field variables, including:

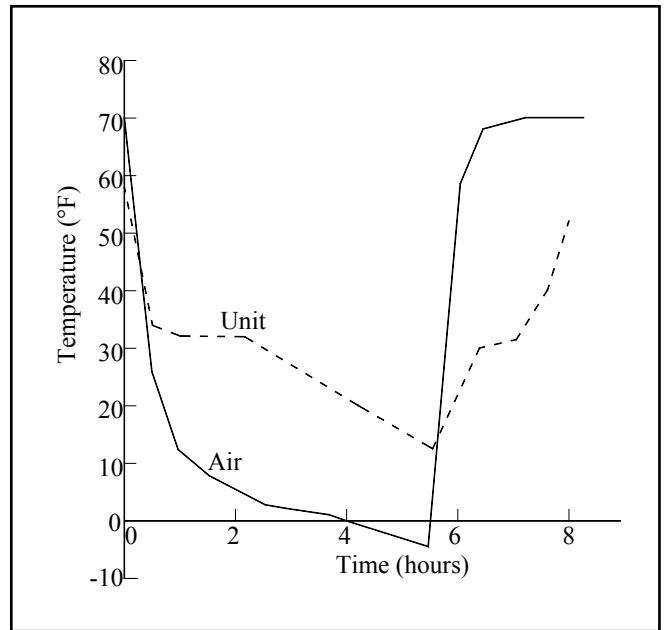

Figure 5—Freeze-Thaw Cycle Requirements

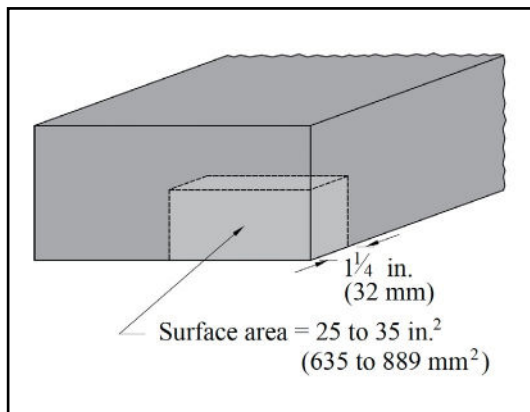

Figure 3—Coupon for Freeze-Thaw Durability Testing

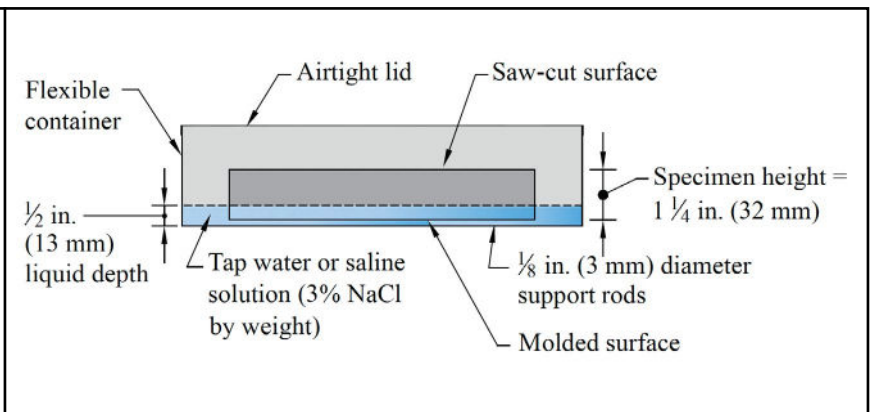

Figure 4—Freeze-Thaw Immersion

- exposure to moisture (source, volume, frequency)
- environment (drainage, exposure to shade or sunlight, exposure to salt and chemicals) and
- temperature (rate of change, peak values, number of cycles, cycle lengths).

C1262 testing is carried out on five specimens representative of the entire lot. These units should be marked for identification, as for C140/C140M testing. Specimens are not permitted to be oven-dried prior to starting freeze-thaw testing.

One coupon is saw-cut from each SRW unit. The side of the coupon has a surface area 25 to 35 in.² (161 to 225 cm²) and a thickness of 1¼ in. ± 1/16 in. (32 ± 2 mm) (see Figure 3). The coupon should be cut from the exposed face of the unit (as it will be placed in service), unless that face is split, fluted, ribbed or otherwise nonplanar. In these cases, the coupon should be cut from another flat molded surface. Saw-cut coupons are then rinsed in water (not submerged), brushed with a soft bristle brush to remove residue and any loose particles, then allowed to air dry on edge for at least 48 hours.

Each specimen is placed in a container, as shown in Figure 4, with the appropriate test solution. After one hour, more liquid is added as necessary to maintain the prescribed level. After 24 hours in the container, the specimen is removed and allowed to drain for one minute on a 3/8-in. (9.5-mm) or coarser wire mesh, removing surface water with a damp cloth. The specimen is immediately weighed to determine the reference

weight W_p , after which the specimen is returned to the container and additional water or saline is added if necessary prior to the cyclic freeze-thaw testing.

Specimens are then subjected to freezing and thawing cycles, as follows (see Figure 5):

Freeze cycle: 4 to 5 hr, or longer to ensure that all water is frozen, at 0 ± 10°F (-17 to -5°C) air temperature

Thaw cycle: 2.5 to 96 hr, to ensure that all ice has thawed, at 75 ± 10°F (24 ± 5°C) air temperature.

After every 20 cycles when using water (or 10 cycles using saline) any residue is collected, dried and weighed to determine the percentage weight loss, as follows:

- determine weight of residue from each evaluation period, W_r , from (weight of the dried residue and filter paper) - (initial weight of the filter paper)
- add W_r from each evaluation period to determine total accumulated residue weight, $W_{residue}$
- after the freeze-thaw testing is complete, dry each specimen and weigh to determine W_{final}
- calculate the initial weight of the specimen from: $W_{initial} = W_{final} + W_{residue}$
- determine the cumulative weight loss of each residue collection interval both in grams and as a percentage of $W_{initial}$ as shown in Table 2.

Table 2—Procedure for Calculating Weight Loss Due to Freeze-Thaw Testing (ref. 3)

Interval number:	Residue weight, g:	Cumulative weight loss, g:	Cumulative weight loss, %:
1	W_{r1}	$W_{initial} - W_{r1}$	$(W_{initial} - W_{r1}) / W_{initial}$
2	W_{r2}	$W_{initial} - (W_{r1} + W_{r2})$	$[W_{initial} - (W_{r1} + W_{r2})] / W_{initial}$
⋮	⋮	⋮	⋮
n	W_m	$W_{initial} - (W_{r1} + W_{r2} + \dots + W_m)$	$[W_{initial} - (W_{r1} + W_{r2} + \dots + W_m)] / W_{initial}$

REFERENCES

1. *Standard Specification for Dry-Cast Segmental Retaining Wall Units*, C1372. ASTM International, 2017.
2. *Standard Test Methods for Sampling and Testing Concrete Masonry Units and Related Units*, ASTM C140/C140M-14a. ASTM International, 2022b.
3. *Segmental Retaining Wall Units*, SRW-TEC-001-15, Concrete Masonry & Hardscapes Association, 2014.
4. *Compressive Strength Testing Variables for Concrete Masonry Units*, TEK 18-07, Concrete Masonry & Hardscapes Association, 2004.
5. *Standard Test Method for Evaluating the Freeze-Thaw Durability of Dry-Cast Segmental Retaining Wall Units and Related Concrete Units*, ASTM C1262-10. ASTM International, 2010.

ABOUT CMHA

The Concrete Masonry & Hardscapes Association (CMHA) represents a unification of the Interlocking Concrete Pavement Institute (ICPI) and National Concrete Masonry Association (NCMA). CMHA is a trade association representing US and Canadian producers and suppliers in the concrete masonry and hardscape industry, as well as contractors of interlocking concrete pavement and segmental retaining walls. CMHA is the authority for segmental concrete products and systems, which are the best value and preferred choice for resilient pavement, structures, and living spaces. CMHA is dedicated to the advancement of these building systems through research, promotion, education, and the development of manufacturing guides, design codes and resources, testing standards, and construction practices.

Disclaimer:

The content of this CMHA Tech Note is intended for use only as a guideline and is made available “as is.” It is not intended for use or reliance upon as an industry standard, certification or as a specification. CMHA and those companies disseminating the technical information contained in the Tech Note make no promises, representations or warranties of any kind, expressed or implied, as to the accuracy or completeness of content contained in the Tech Note and disclaim any liability for damages or injuries resulting from the use or reliance upon the content of Tech Note. Professional assistance should be sought with respect to the design, specifications, and construction of each project.