



# Basement Manual

## Design and Construction Using Concrete Masonry

CMU-MAN-002-01



MASONRY &  
HARDSCAPES

# BASEMENT MANUAL

*Design and Construction Using Concrete Masonry*

## **NATIONAL CONCRETE MASONRY ASSOCIATION**

The National Concrete Masonry Association (NCMA) is a not-for-profit organization whose mission is to support and advance the common interests of its members in the manufacture, marketing, research, and application of concrete masonry products. The Association is an industry leader in providing technical assistance and education, marketing, research and development, and product and system innovation to its members and to the industry.

**NATIONAL**  
**NCMA**  
**CONCRETE MASONRY**  
**ASSOCIATION**

## DISCLAIMER

NCMA promotes the use of concrete masonry through the development and dissemination of technical information. This manual was compiled to assist the designer, builder, or owner in the preparation of constructing with concrete masonry. The discussion, design tables, and construction details are intended to assist architects and engineers in the design of foundation walls and to acquaint builders and contractors with recommended construction methods and details.

The material presented does not cover all possible situations but is intended to represent some of the more widely used concrete masonry construction details and other pertinent information. Factors such as soil conditions and building code requirements can vary significantly, even in the same locality. For this reason, the information contained in this handbook is necessarily of a general nature when illustrating typical design conditions, assumptions, and procedures. The actual design of foundation walls, preparation of working drawings, and similar services are best accomplished by a qualified architect or engineering familiar with local conditions and code requirements.

Care has been taken to ensure that the information included in this manual is as accurate as possible. However, NCMA does not assume responsibility for errors or omissions resulting from the use of this manual or in preparation of plans or specifications.

## COPYRIGHT

Copyright © 2001 National Concrete Masonry Association  
NCMA Publication Number TR 68B  
ISBN 1-881384-14-4

### NCMA TECHNICAL STAFF

Robert D. Thomas, *Vice President of Engineering*  
Dennis W. Graber, P.E., *Director of Technical Publications*  
Jason J. Thompson, *Structural Engineer*  
R. Lance Carter, P.E., *Manager of Engineered Landscape Products*  
Jeffrey H. Greenwald, P.E., *Director of Research and Development*  
Charles B Clark, A.I.A., P.E., *Manager of Codes, Standards and National Accounts*

NATIONAL

**NCMA**

CONCRETE MASONRY  
ASSOCIATION

Published by  
National Concrete Masonry Association  
13750 Sunrise Valley Drive  
Herndon, VA 20171  
[www.ncma.org](http://www.ncma.org)

Printed in the United States of America

# Table of Contents

## Chapter 1 – Introduction

Section 1.1 – Application	Page 1-1
Section 1.2 – Attributes of Concrete Masonry	Page 1-2
Section 1.2.1 – Low Cost for Construction and Maintenance	Page 1-2
Section 1.2.2 – Strength and Durability	Page 1-3
Section 1.2.3 – Interior Architecture	Page 1-3
Section 1.2.4 – Energy Efficiency	Page 1-3
Section 1.2.5 – Noise Control	Page 1-3
Section 1.2.6 – Fire Resistance	Page 1-4
Section 1.2.7 – Safe Haven	Page 1-4
Section 1.2.8 – Radon Infiltration Resistance	Page 1-4
Section 1.2.9 – Insect Resistance	Page 1-4

## Chapter 2 – Structural Design

Section 2.1 – General Design Considerations and Assumptions	Page 2-1
Section 2.2 – Loads on Foundation Walls	Page 2-4
Section 2.2.1 – Dead Loads	Page 2-4
Section 2.2.2 – Live Loads	Page 2-5
Section 2.2.3 – Lateral Earth Pressure	Page 2-5
Section 2.2.4 – Wind and Blast Pressure	Page 2-8
Section 2.2.4.1 – Wind	Page 2-8
Section 2.2.4.2 – Blast	Page 2-11
Section 2.2.5 – Earthquake Loads	Page 2-11
Section 2.2.6 – Load Combinations	Page 2-14
Section 2.2.7 – Load Distribution and Structural Continuity	Page 2-14
Section 2.3 – Structural Elements	Page 2-15
Section 2.3.1 – Pilasters	Page 2-15
Section 2.3.2 – Columns	Page 2-15
Section 2.3.3 – Lintels and Beams	Page 2-15
Section 2.3.4 – Anchors	Page 2-15
Section 2.3.4.1 – Post-Installed Anchors	Page 2-16
Section 2.3.4.2 – Embedded Anchors	Page 2-16
Section 2.4 – Bending Moments and Shear Forces	Page 2-22
Section 2.4.1 – Simply Supported Elements	Page 2-22
Section 2.5 – Section Properties	Page 2-34
Section 2.6 – Allowable Stress Design	Page 2-39
Section 2.6.1 – Design Assumptions	Page 2-39
Section 2.6.1.1 – Material Properties	Page 2-39
Section 2.6.2 – Reinforced Concrete Masonry Walls	Page 2-39
Section 2.6.3 – Unreinforced Concrete Masonry Walls	Page 2-39
Section 2.6.4 – Pre-Engineered Design	Page 2-86
Section 2.7 – Empirical Design	Page 2-86
Section 2.7.1 – Design Assumptions	Page 2-86
Section 2.8 – Design Examples	Page 2-91

Section 2.8.1 – Design Example No. 1	Page 2-91
Section 2.8.2 – Design Example No. 2	Page 2-92

### **Chapter 3 – Energy Conservation and Noise Abatement**

Section 3.1 – Energy Conservation with Foundation Walls	Page 3-1
Section 3.1.1 – Building Code Requirements	Page 3-1
Section 3.1.2 – Typical Thermal Values	Page 3-1
Section 3.2 – Insulation Strategies	Page 3-2
Section 3.2.1 – Integral Insulation	Page 3-2
Section 3.2.2 – Exterior Insulation	Page 3-7
Section 3.2.3 – Interior Insulation	Page 3-7
Section 3.3 – Sound Abatement	Page 3-8
Section 3.3.1 – Sound Transmission Classification	Page 3-8

### **Chapter 4 – Water Penetration Resistance**

Section 4.1 – Introduction	Page 4-1
Section 4.2 – Identifying Potential Problems	Page 4-1
Section 4.2.1 – Sources of Water	Page 4-1
Section 4.2.2 – Potential Water Penetration Locations	Page 4-2
Section 4.2.2.1 – Construction Considerations	Page 4-2
Section 4.3 – Diverting Surface Water	Page 4-3
Section 4.4 – Drainage Systems	Page 4-4
Section 4.4.1 – Perimeter Drains	Page 4-5
Section 4.4.2 – Free Draining Backfill	Page 4-7
Section 4.4.3 – Sump Pumps	Page 4-7
Section 4.4.4 – Wall Drains	Page 4-7
Section 4.4.5 – Drainage Boards	Page 4-7
Section 4.5 – Damp-Proofing and Waterproofing	Page 4-8
Section 4.5.1 – Damp-proofing	Page 4-9
Section 4.5.2 – Waterproofing	Page 4-10
Section 4.6 – Condensation	Page 4-10
Section 4.7 – Groundwater Drainage	Page 4-13
Section 4.8 – Flashing	Page 4-14

### **Chapter 5 – Crack Control**

Section 5.1 – Introduction	Page 5-1
Section 5.2 – Sources of Potential Cracks	Page 5-1
Section 5.3 – Accommodating Movement	Page 5-1
Section 5.3.1 – Controlling Shrinkage	Page 5-1
Section 5.3.1.1 – Control Joints	Page 5-2
Section 5.3.1.2 – Horizontal Reinforcement	Page 5-3
Section 5.3.1.3 – Construction Practices	Page 5-4
Section 5.3.2 – Controlling Differential Movement	Page 5-5
Section 5.3.3 – Controlling Excessive Deflection	Page 5-5
Section 5.3.4 – Controlling Differential Settlement	Page 5-5
Section 5.3.5 – Controlling Structural Overload	Page 5-5

<b>Chapter 6 – Insect Protection</b>	
Section 6.1 – Introduction	Page 6-1
Section 6.2 – Site Conditions	Page 6-2
Section 6.3 – Reducing Entry Routes	Page 6-3
Section 6.3.1 – Minimizing Cracks	Page 6-3
Section 6.3.2 – Minimum Clearance to Soil	Page 6-4
Section 6.3.3 – Capping Concrete Masonry Walls	Page 6-4
Section 6.3.4 – Exterior Insulation	Page 6-4
Section 6.3.5 – Additional Considerations for Crawl Spaces	Page 6-5
Section 6.4 – Chemical Treatments	Page 6-5
<b>Chapter 7 – Soil Gas Resistance</b>	
Section 7.1 – Introduction	Page 7-1
Section 7.2 – Site Evaluation	Page 7-1
Section 7.3 – Reducing Radon Entry	Page 7-2
Section 7.3.1 – Concrete Masonry Basements	Page 7-2
Section 7.3.2 – Crawl Spaces	Page 7-4
Section 7.3.2.1 – Attached Crawl Spaces	Page 7-4
Section 7.3.3 – Slabs-On-Grade	Page 7-5
Section 7.3.3.1 – Slabs at Difference Elevations	Page 7-6
Section 7.3.4 – Other General Precautions	Page 7-6
Section 7.3.4.1 – Concrete Joints and Pipe Openings	Page 7-6
Section 7.3.4.2 – Drainage Systems	Page 7-6
Section 7.4 – Radon Removal	Page 7-8
Section 7.4.1 – Depressurization	Page 7-8
Section 7.4.1.1 – Subslab Depressurization	Page 7-8
Section 7.4.1.2 – Perimeter Drain Depressurization	Page 7-9
Section 7.4.2 – Crawl Space Venting	Page 7-9
Section 7.4.3 – Attached Crawl Space Venting	Page 7-10
<b>Chapter 8 – Construction</b>	
Section 8.1 – Introduction	Page 8-1
Section 8.2 – Materials	Page 8-4
Section 8.2.1 – Concrete Masonry Units	Page 8-4
Section 8.2.1.1 – Concrete Masonry Unit Properties	Page 8-4
Section 8.2.1.2 – Concrete Masonry Unit Admixtures	Page 8-5
Section 8.2.2 – Mortar	Page 8-5
Section 8.2.2.1 – Mortar Materials	Page 8-5
Section 8.2.2.2 – Mortar Mixing	Page 8-6
Section 8.2.2.3 – Mortar Admixtures	Page 8-6
Section 8.2.3 – Grout	Page 8-6
Section 8.2.3.1 – Grout Materials	Page 8-6
Section 8.2.3.2 – Grout Admixtures	Page 8-6
Section 8.2.4 – Reinforcing Steel	Page 8-7
Section 8.3 – Footing Construction	Page 8-8
Section 8.4 – Concrete Masonry Construction	Page 8-9

Section 8.4.1 – Laying of Units	Page 8-9
Section 8.4.2 – Grout Placement	Page 8-10
Section 8.4.2.1 – Low-Lift Grouting	Page 8-10
Section 8.4.2.2 – High-Lift Grouting	Page 8-11
Section 8.5 – Construction Tolerances	Page 8-12
Section 8.5.1 – Tolerances for Placement of Reinforcing Bars	Page 8-12
Section 8.5.2 – Tolerances for Constructing Masonry	Page 8-12
Section 8.5.3 – Tolerances for Concrete Footings	Page 8-13
Section 8.5 – Backfilling	Page 8-13

## **Appendix**

Appendix A – Metric Conversions	Page A-2
Appendix B – Definitions	Page A-3
Appendix C – Notations	Page A-20
References	Page A-22

# Chapter 1

## Introduction

### 1.1 Application

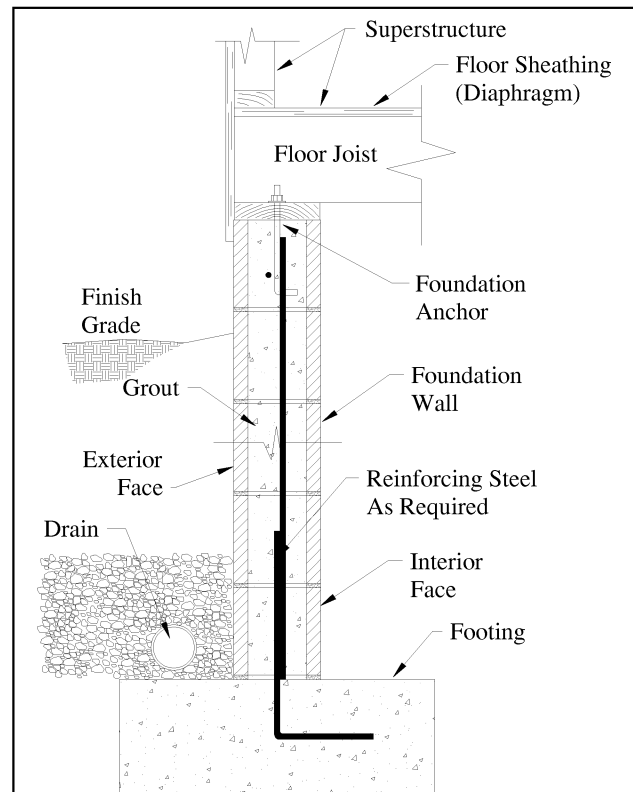
As a general definition, foundation walls are building walls constructed below the floor nearest to the finish grade. Foundation walls serve as support for the superstructure or other structural members, as enclosure walls around excavated areas, or as both supporting and enclosure walls. (Foundation walls enclosing usable areas under a building are also called basement walls.) In turn, footings support foundation walls, which transfer the applied loads to the soil on which they rest.

Historically, the use of concrete masonry in foundations was confined almost entirely to residential and light commercial construction where vertical and lateral loads carried by the foundations seldom exceed those that can be safely resisted by plain concrete masonry of practical and economical thickness. However, over the past several decades, the development of reinforcing technologies and design philosophies has expanded the use of concrete masonry to nearly any conceivable design or function. Some of these applications include using reinforced concrete masonry in the construction of:

- deep foundations;
- foundation or basement walls subjected to large lateral soil pressures;
- foundation or basement walls supporting heavy compressive loads;
- foundation or basement walls where the unsupported wall length or height will exceed that recommended for plain (unreinforced) concrete masonry; and
- any combination of these applications.

The discussion, design tables, and suggested construction details presented in this manual

have been prepared to assist architects and engineers in the design of unreinforced and reinforced concrete masonry foundation and basement walls, and to acquaint builders and owners with the recommended construction details and practices associated with these technologies.



**Figure 1-1: Typical Foundation Schematic**

Since soil conditions, building code requirements, and other factors affecting the design may vary appreciably even within the same geographic locality. Therefore, the information contained within this document is necessarily of a general nature and intended only to illustrate typical design conditions, assumptions, and procedures. The drawings included are not intended to serve, and should be not used as, working



drawings. A qualified architect or structural engineer familiar with local conditions and code requirements is best qualified to render working drawings and similar services.

### **1.2 Attributes of Concrete Masonry**

Concrete masonry possesses numerous attributes that make it well suited for basement and foundation wall construction; including its strength, durability, insulating properties, and resistance to fire, termites, and noise. These attributes are the primary reasons why both basements and other structures have historically been constructed of concrete masonry.

Often, basements are constructed with standard “gray” block, which can be unfinished or used as a backup for other finishes such as plaster, paint, or gypsum wallboard. Where desired however, architectural units are used to add attractive finishes to the interior wall of a basement. The incorporation of architectural units into foundation construction removes the need to apply a secondary finish. Architectural units can be used as the finish surface for interior basement walls, or in the case of an exposed foundation (such as a walkout basement), for the exterior surface.

One often-overlooked advantage of concrete masonry is its ability (as a result of its modular size) to easily accommodate variations in floor plans or wall heights differing from traditional formed concrete walls. Corners, tees, and arcs can easily be laid out for intersecting walls, returns, bay windows, and fireplaces as shown in Figure 1.2. Forming or framing these floor plan changes with other materials is often more difficult and costly.



**Figure 1-2: Concrete Masonry Can Accommodate Most Any Foundation Layout**

#### ***1.2.1 Low Cost for Construction and Maintenance***

Masonry construction costs are relatively low since the materials are inexpensive, the construction is straightforward, and the work proceeds rapidly. This is particularly true if the basement walls are to be finished, since square and plumb masonry walls are easy to fur out and drywall. Other wall systems lack the precision of handcrafted masonry walls. Additionally, the use of architectural concrete masonry units to provide a finished wall surface can eliminate the costs associated with adding additional finish materials.

Maintenance costs for concrete masonry walls are low as well since concrete masonry is tough, durable, and colorfast. Painting is not needed unless it is desired on the exposed portions of the foundation. In addition, if deemed necessary, cleaning is

typically accomplished with only soap and water.

### ***1.2.2 Strength and Durability***

Disasters such as earthquakes, hurricanes, and explosions have repeatedly shown the capacity of properly designed and constructed concrete masonry structures.

The high strength of concrete masonry makes it ideal for resisting vertical structural loads and lateral soil pressures on basement walls, especially since concrete masonry walls can be easily and economically reinforced. Design information and selection tables are provided in Chapter 2 to assist engineers, architects, and builders in evaluating the structural adequacy of concrete masonry foundation walls.

### ***1.2.3 Interior Architecture***

A wide variety of colors and textures of concrete masonry units are available to meet the needs of the owner, builder, or architect. Faces that are split, scored, burnished, and fluted provide added options to standard formed block surfaces. These architectural units can be used in the entire wall or only in portions to achieve specific patterns.

Additionally, basement walls can be constructed of standard gray block and finished at a later date by the owners. Since masonry walls are constructed square and plumb, finishing with furring strips and drywall is straightforward.

Because of the modular nature of concrete masonry, windows and doors of a variety of shapes and sizes can be easily incorporated into masonry wall construction, giving basements warm natural lighting. For additional protection and privacy, glass block units can be used in lieu of traditional glass windows.

### ***1.2.4 Energy Efficiency***

In many areas, insulation is not required for concrete masonry basement walls. If desired, or when required, concrete masonry walls are easily insulated with a variety of products including rigid board insulation, insulation inserts, loose fill insulation, foam insulation, and fibrous batt insulation. Depending on the particular site conditions and the preference of the owner, insulation may be placed on the outside of block walls, on the interior side of the walls, or in the ungrouted cores of hollow units.

Additionally, the thermal mass of concrete masonry contributes to maintaining consistent temperatures in basements, thus providing a more comfortable area. Walkout basement doors and large window wells may also contribute to reducing heating loads by allowing solar energy into basements. This issue is covered in further detail in Chapter 3.

### ***1.2.5 Noise Control***

Concrete masonry is an ideal noise control material in two important ways. First, masonry walls act as barriers which block sound transmission over a wide range of frequencies. For above grade foundation walls, outdoor sounds are thus reflected away by the concrete masonry. Interior masonry walls also isolate sound between rooms. This property of concrete masonry to impede the passage of sound has made it a material of choice for highway sound walls, apartments, and hotel separation walls. For below grade spaces however, the more relevant sound characteristic of masonry may be its ability to absorb and dissipate noise generated within a room. Refer to Chapter 3 for additional information and strategies on noise abatement.

### ***1.2.6 Fire Resistance***

Concrete masonry is a noncombustible material, effectively resisting the passage of flames, smoke, and heat through its mass. Accordingly, building codes assign high fire ratings to concrete masonry walls, making them superior firewalls for hotels, apartments and other structures. These same attributes make concrete masonry desirable for foundation walls and basements to safeguard against the spread of fires and to support the structure above without degradation under extreme heat.

### ***1.2.7 Safe Haven***

Basements provide areas of refuge during violent storms, tornadoes, or hurricanes since the surrounding earth protects the basement area from high winds and flying debris. Concrete masonry is especially well suited for such safe havens because of its inherent strength and toughness, as demonstrated by the excellent performance of above grade concrete masonry structures during such natural disasters.

### ***1.2.8 Radon Infiltration Resistance***

Concrete masonry basements effectively resist infiltration of radon and soil gases with little increase in the cost of the basement. Chapter 7 describes methods to reduce radon infiltration based on *Building Radon Resistant Foundations* (Ref. 1). Most of the recommendations contained herein and in Reference 1, such as providing barriers on the exterior face of the walls, are typically already provided as part of the standard practice for basement construction.

For localities prone to radon infiltration, subslab depressurization systems are installed to remove radon before it can enter a home. The cores of hollow concrete masonry units can be used to locate vents used to reduce radon concentrations. These systems, as well as others that promote a

healthy living environment, can be easily accommodated with concrete masonry construction.

### ***1.2.9 Insect Resistance***

For many areas of the country, protection from termite infestation is an important design consideration. However, since termites feed only on materials that contain cellulose (most notably wood), masonry construction is not affected. Nonetheless, when incorporating a wood superstructure with a concrete masonry foundation, insect protection strategies need to be considered as outlined in Chapter 6.

## Chapter 2

# Structural Design

### 2.1 General Design Considerations and Assumptions

The design and construction of masonry in general can be broken into two distinct categories; that of reinforced and unreinforced masonry. Each type of construction has specific benefits in certain applications and design circumstances. Since both reinforced and unreinforced masonry are used extensively in foundation construction, each will be addressed in forthcoming sections of this manual.

Furthermore, the design of masonry can be broken into several individual categories, specifically; empirical design, allowable stress design, and strength design. Allowable stress design and strength design of masonry are each engineered design methods, requiring the knowledge of; magnitude and location of applied loads, strength of materials used in construction, and size and location of structural elements. Conversely, the empirical design approach, occasionally referred to as a “cook book” method, requires little knowledge of the loads or materials, but instead relies upon the historical performance of masonry as a construction material in specific categories of use.

Due to the similarities between strength design and allowable stress design of masonry, only the latter will be covered in this manual. It should be stressed that although the resulting design configuration is often similar – if not identical – between allowable stress design and strength design, the underlying assumptions, loads, and material design strengths vary significantly between the two practices. Hence, the design loads and structural capacities presented in this manual should only be

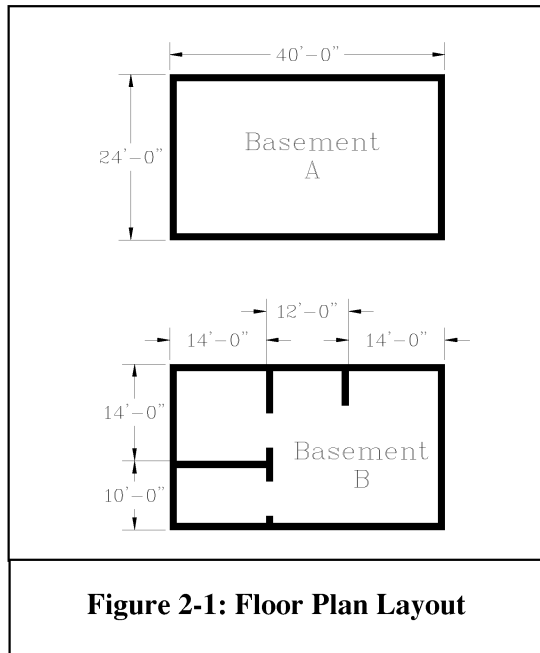
applied to allowable stress design methods, and not extrapolated to strength design procedures. Empirically designed masonry, it is discussed briefly in Section 2.7.

The principal factors to be considered in the structural design of foundation walls are:

1. the magnitude of the vertical and horizontal loads which the walls must resist;
2. the manner in which the walls resist the applied loads; and
3. the general design and layout of the building.

Both the applied loads and the wall design will vary with the general layout of the building under consideration. As an example, take the two basement configurations shown in Figure 2-1. Each basement contains roughly the same square footage, however, basement configuration B will exhibit significantly more rigid characteristics and carry more lateral load than basement A due to the support provided by the interior cross walls. Basement configuration B is more apt to distribute lateral soil pressures both vertically (to the footing below the wall and the floor above the wall) and horizontally (to the interior cross walls). Thus the total load such a wall can carry is greater than configuration A, which will distribute most lateral loads vertically.

A similar phenomenon is observed when offsets are introduced to a rectangular floor plan. However, to simplify the philosophy presented in this manual, most discussion will assume that the distribution of loads is in only one direction.



Although the number of design considerations is limitless, this manual will attempt to address some of the most common considerations of residential basement construction and design.

Figure 2-2 shows several types of concrete masonry foundations walls. Basement walls are one of the most common foundation wall types that are designed; hence, they are a primary focus of this manual. Basement walls (as addressed in this manual) are walls either partially or fully below grade, which enclose (or are enclosed by) habitable or potentially habitable space (see Figure 2-2a).

By contrast, crawl space walls, which include curtain walls and possibly pier footings, do not enclose habitable space (Figure 2-2b). Crawl space walls tend to be shorter than basement walls and are not generally supported laterally by a slab at their base.

Stem walls are foundation walls that typically do not support unbalanced (equal backfilling on both sides of the wall) backfill loads (Figure 2-2c).

Basement, crawl space, and stem walls are typically supported at their tops by a first floor diaphragm. Retaining walls, in contrast, are usually not supported at their tops unless it is with tiebacks or a whaler (Figure 2-2d).

The above definitions are general in nature. It is important to note that many walls may overlap the configurations outlined above. For instance, a basement wall may have to act more as a cantilevered retaining wall if a large open stairway is constructed adjacent to it. Similarly, crawl space walls may sometimes step down to become basement walls. The design of all of these walls however, must consider loads transmitted from the above grade structure and the pressure exerted by the soil.

Because masonry units, mortar, and grout are strong in compression and relatively weaker in tension, much of the discussion in this section is focused on assuring that the tensile strength of foundation walls is adequate. In areas of high-wind, high seismic risk, or large lateral earth pressures, reinforcing steel may need to be incorporated into concrete masonry walls to increase the tensile strength and shear strength of the walls.

Compressive loads on masonry walls must also be checked, but because of the high compressive strength inherent in concrete masonry construction, typical wall widths are usually more than sufficient to carry and distribute the loads from residential and light industrial buildings. Moreover, compressive loads sometimes offset, or counteract, the oftentimes more critical lateral soil pressures. It is often conservative, therefore, to ignore the vertical loads since they tend to reduce soil pressure effects. However, in light of providing economical designs, interaction diagrams are provided in this

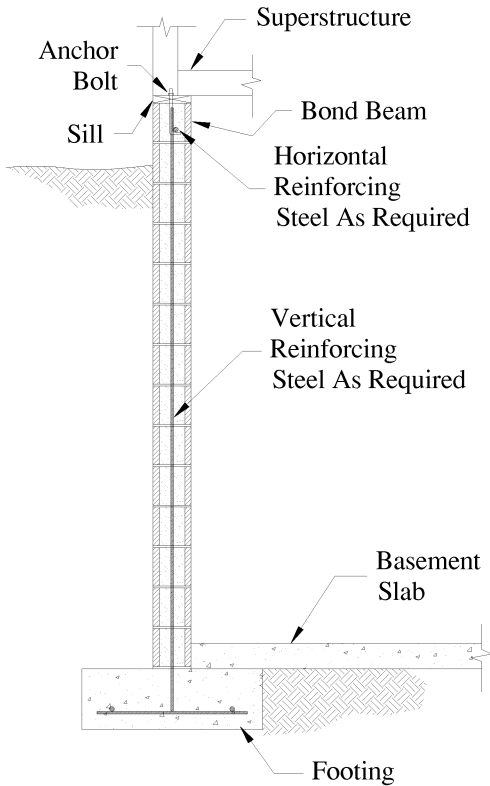


Figure 2-2a: Basement Wall

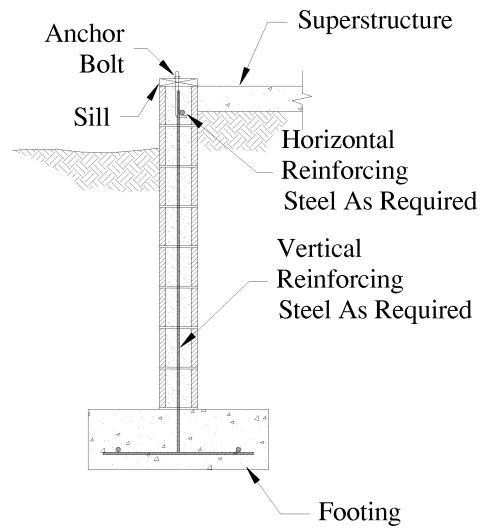


Figure 2-2c: Stem Wall

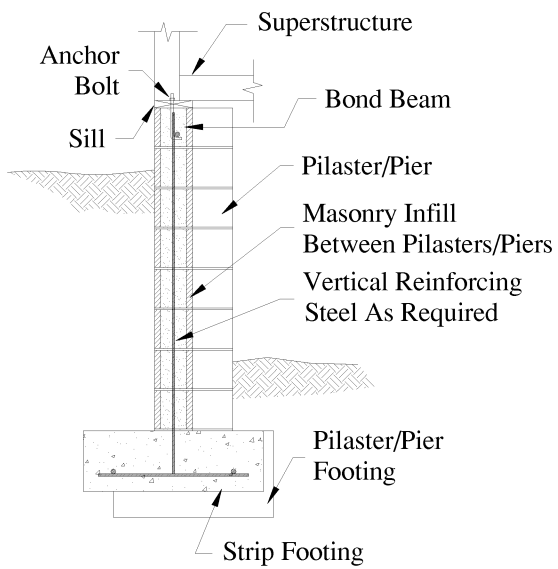


Figure 2-2b: Crawl Space Wall

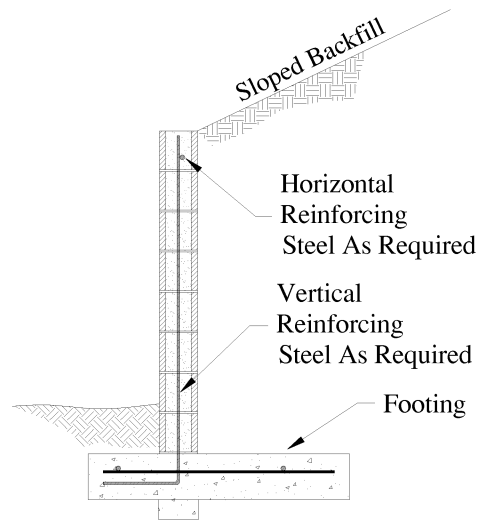


Figure 2-2d: Retaining Wall

Figure 2-2: Typical Foundation Walls

manual to take into account the combined effects of vertical and lateral loads.

This manual primarily bases design procedures, tables, and minimum structural design requirements on the provisions reported by the Mason Standards Joint Committee in the national masonry design Code ACI 530/ASCE 5/TMS 402 (Ref. 8). In addition to these provisions of the MSJC, requirements established in the 2000 International Building Code (IBC) (Ref. 6) are also presented. For additional information, refer to these and other referenced documents.

## **2.2 Loads on Foundation Walls**

Loads may be classified as either vertical (generally gravity) or horizontal (lateral), as static (not changing quickly over time) or dynamic (quickly changing over time), as concentrated, uniformly distributed, or other depending upon their source, nature, and how they are transmitted to a structural member. Since a safe and economical foundation wall is one that will carry the maximum expected loads with a reasonable factor of safety, successful design of these walls is greatly dependent upon the assumptions made as to the loads acting upon the superstructure and the foundation.

A complete discussion of the various forces that are required for consideration in building design by the International Building Code (Ref. 6) is not included here, but the designer should be familiar with the subject as it pertains to the design of foundations. Although the general observations presented in this section are applicable to most designs, there are many factors and variables that cannot be covered in detail in this brief discussion. Accordingly, designers interested in topics not covered herein are encouraged to refer to

current published literature specific to the subject.

### **2.2.1 Dead Loads**

The dead load acting on a foundation wall consists of the weight of the superstructure bearing on the wall and the weight of the wall itself. These loads are easily calculated from the weights of the materials used in the construction. The key to identifying a dead load is that it is constant in magnitude and location.

In the design of foundation walls, it can be assumed that vertical compressive stresses resulting from dead loads will be effective in reducing any vertical tensile stresses developed in resisting bending. It is important to remember that only moments and stresses due to dead loads may safely be considered as contributing to opposing moments and stresses due to lateral forces. In contrast, live loads or other transient types of loads should not be considered effective in opposing tensile stresses developed from lateral loads as their magnitude or orientation can change quickly over time.

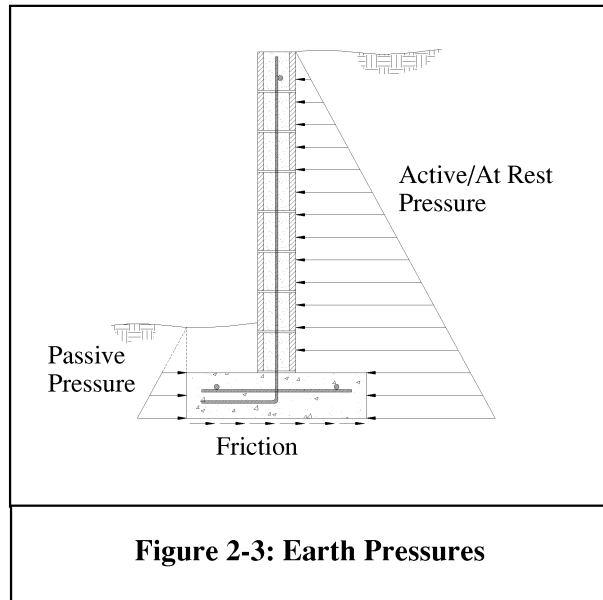
Precautions should be taken during erection to insure that the dead load assumed in the design will actually be present and acting on the foundation before the foundation is subjected to lateral load. For example, if the design of a basement wall is based on the assumption that the vertical dead load of the superstructure will reduce the tensile stresses due to earth pressure, the walls should not be backfilled prior to erection of the supporting diaphragm. If early backfilling is unavoidable, temporary bracing should be provided to ensure that applied loads do not exceed the strength of the wall. More information on bracing of masonry construction is provided in Chapter 8.

### 2.2.2 Live Loads

As a simple definition, live loads are any loads applied to a building by its use or occupancy. The IBC (Ref. 6) does not recognize “environmental loads” due to wind, snow, rain, or earthquakes as live loads. Instead, live loads result from the weight of the people and furnishings within a building. Live loads may be variable, transient, or moving; as for example with the weight of people or moveable objects.

The type and magnitude of live loads to be considered will vary according to locality, occupancy, and other factors. Static live loads generally may be predicted to a reasonable degree of accuracy. Building codes (Ref. 13) specify minimum design static live loads in pounds per square foot for floor areas. Live loads, although variable in magnitude and location, are treated in essentially the same manner as dead loads and analyzed as if applied statically to the structure. A summary of relevant uniform live loads for one and two family residential dwellings is presented in Table 2-1.

Location	Uniform Load (psf)
Uninhabitable attics without storage	10
Uninhabitable attics with storage	20
Habitable attics and sleeping areas	30
All other interior areas	40



**Figure 2-3: Earth Pressures**

### 2.2.3 Lateral Earth Pressure

Foundation walls enclosing excavated areas must resist lateral forces resulting from the pressure of the retained earth against the exterior wall face.

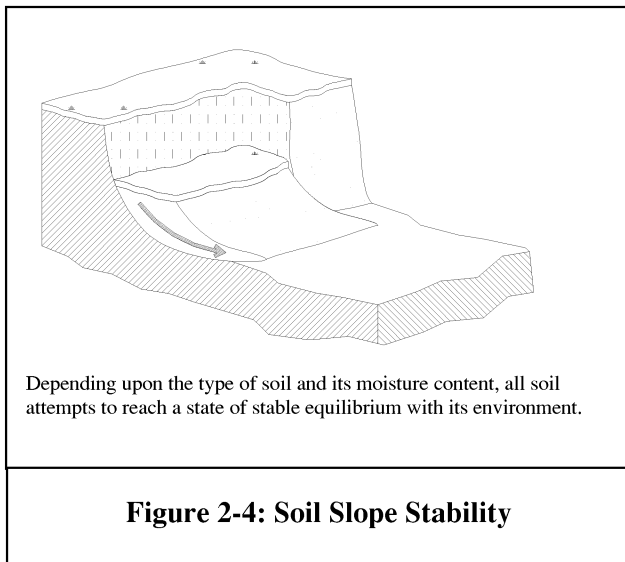
The soil pressure the wall must resist depends on a number of factors including the soil type, the soil density, the amount of water in the soil, and the rigidity of the wall itself. Various theories and assumptions have been made over the years to help describe the effects of these, as well as other soil parameters. Three types of soil pressures are now commonly used in design; active earth pressure, at-rest earth pressure, and passive earth pressure.

Passive pressure develops when an object is being pushed against a soil mass. In such cases the internal friction of the soil works to resist the applied load. Passive pressure, along with the friction between the footing and the soil, helps prevent foundation and retaining walls from sliding. (Figure 2-3) Passive pressure should not be used as a resisting force in design unless it will be present for the design life of the structure.

While passive pressure can be thought of as the pressure exerted *on* the soil by a foundation, active pressure and at-rest pressure are pressures exerted *by* the soil on the foundation. These pressures develop as gravity and other factors try to move the soil mass into a more stable position. (Figure 2-4) As a general comparison, passive



pressure opposes the motion of a structure while active and at-rest pressures advances the motion of a structure. The difference between active and at-rest pressure depends largely on the rigidity of the wall system supporting the soil. If the wall can rotate or deflect away from the retained soil somewhat, the internal friction of the soil is mobilized to help resist further movement. Conversely, a highly rigid wall does not deflect and allow the internal friction of the soil to be mobilized, therefore greater earth pressures are generated.



As a general rule-of-thumb, residential concrete masonry basement walls that are supported at the top by wood floor diaphragms and at the bottom by the foundation are typically designed to resist active earth pressures. If sufficient deflection is not anticipated, as may be seen in some short heavily reinforced basement walls supported by concrete diaphragms, at-rest soil pressures are used in the design. For further guidance refer to Table 2-2,

which summarizes typical minimum wall deflections necessary for active soil pressures to control the design.

Since the physical properties of the soil, soil conditions, and other factors influencing the pressure of retained earth on a wall may vary considerably even in the same locality, the magnitude of the earth pressure expected to act on a foundation wall should be estimated by someone familiar with actual conditions and with the type of soil in question. In large projects where soil tests and foundation studies are made, theoretical methods of estimating lateral earth pressures should be used. In practice, soil tests and theoretical analyses are not often incorporated into small-scale projects. When the soil properties are not determined by actual test, empirical or semi-empirical methods are generally employed as discussed in the following paragraphs. When estimating lateral earth pressures by empirical methods, it is advisable to check the design through comparison with previous construction of the same type and in the same locale.

In basement design, all three of the above pressures, active, at-rest, and passive, are all commonly estimated using the equivalent fluid pressure approach, which assumes the soil pressure increases linearly with depth. (Figure 2-5) Common equivalent fluid pressures for a variety of soils are shown in Table 2-3 along with other soil parameters. Where saturated soils are anticipated, the density of water (62.4 pcf) must be added to the design pressures of Table 2-3.

Soil Type	Minimum Deflection Necessary (in.)
Dense cohesionless (sand)	0.0005 times wall height
Loose cohesionless (sand)	0.002 times wall height
Stiff cohesive (clay)	0.01 times wall height
Soft cohesive (clay)	0.02 times wall height

**Table 2-3: Typical Values for Soil Equivalent Fluid Pressures**

Soil Classification	Internal Friction Angle (degrees)	Soil Consistency	Unit Weight of Soil (pcf)	Equivalent Soil Fluid Pressure, P <sub>EF</sub> (psf/ft of depth)		
				Active	At-Rest	Passive
Coarse sand or sand and gravel	45	Compact	140	24	41	816
	38	Firm	120	29	46	505
	32	Loose	90	28	42	293
Medium sand	40	Compact	130	28	46	598
	34	Firm	110	31	49	389
	30	Loose	90	30	45	270
Fine sand	34	Compact	130	37	57	460
	30	Firm	100	33	50	300
	28	Loose	85	31	45	235
Fine silty sand or sandy silt	32	Compact	130	40	61	423
	30	Firm	100	33	50	300
	28	Loose	85	31	45	235
Fine uniform sand	30	Compact	135	45	68	405
	28	Firm	110	40	58	305
	26	Loose	85	33	48	218
Clay silt	20	Medium	120	59	79	245
		Soft	90	44	59	184
Silty clay	15	Medium	120	71	89	204
		Soft	90	53	67	153
Clay	10	Medium	120	85	99	170
		Soft	90	63	74	128
Clay	0	Medium	120	120	120	120
		Soft	90	90	90	90

The values provided in Table 2-3 assume a level backfill, a vertical wall face in contact with the soil, and no friction between the interface of the wall and the soil. For situations other than those covered by Table 2-3, a more detailed analysis may be warranted.

For sloping backfill or other soil types, the coefficient of active pressure can be determined from the following relationship:

$$K_a = \frac{\cos^2(\phi)}{\left(1 + \sqrt{\frac{\sin(\phi)\sin(\phi - \alpha)}{\cos(\alpha)}}\right)^2}$$

Similarly, the coefficient of passive pressure can be calculated from:

$$K_p = \frac{\cos^2(\phi)}{\left(1 - \sqrt{\frac{\sin(\phi)\sin(\phi + \alpha)}{\cos(\alpha)}}\right)^2}$$

Finally, the coefficient for at-rest pressure is calculated as:

$$K_o = 1 - \sin(\phi)$$

Where  $\phi$  is the internal friction angle of the soil and  $\alpha$  is the angle of the slope of the backfill measured relative to the horizon.

Under certain conditions, earth pressures on basement walls may be substantially increased through the application of superimposed loads on the earth adjacent to the walls. This may occur where a roadway, other structures, stacked materials, or heavy equipment are located or operated near the structure during or subsequent to construction. When considering the effect of such superimposed loads, designers frequently follow the practice of converting the superimposed load to an equivalent

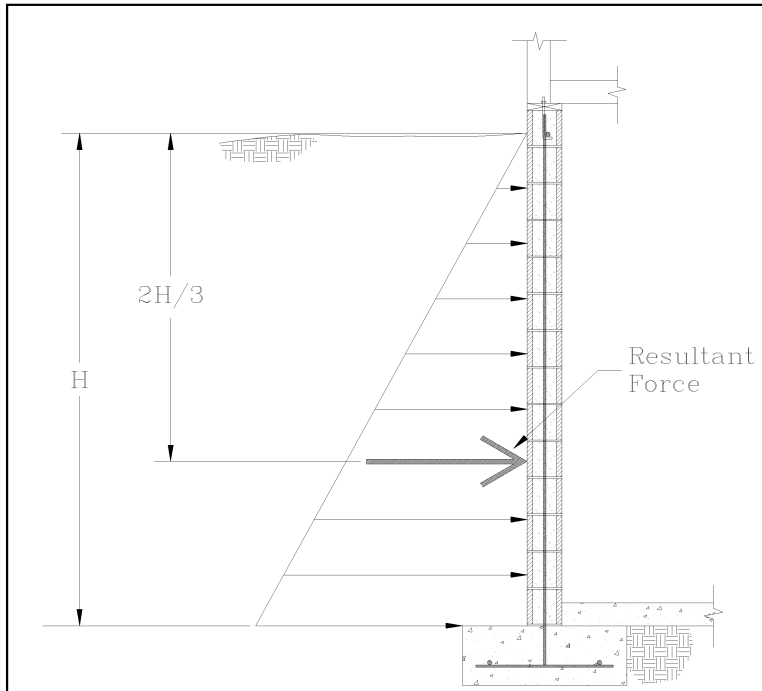
depth of fill. For example, consider a load of 300 psf adjacent to a foundation wall retaining a compacted coarse sand fill weighing 140 pcf. Assuming that at-rest conditions apply, from Table 2.3 the equivalent fluid pressure is 41 psf. Taking the ratio of the lateral at-rest earth pressure (41 psf/ft) to the unit weight of the soil (140 pcf) we see that approximately 29.3% of the soil's weight is transferred laterally to the foundation. Assuming that a similar phenomenon will apply to the superimposed load of 300 psf, we multiply the surcharge load by 29.3% to yield 87.9 psf transferred laterally from the surcharge load to the foundation. The magnitude and position of the resultant of the lateral earth pressure on the wall is calculated assuming a trapezoidal earth pressure diagram (Figure 2-6) in lieu of the triangular diagram generally assumed where no superimposed load or surcharge is considered.

### 2.2.4 Wind and Blast Pressure

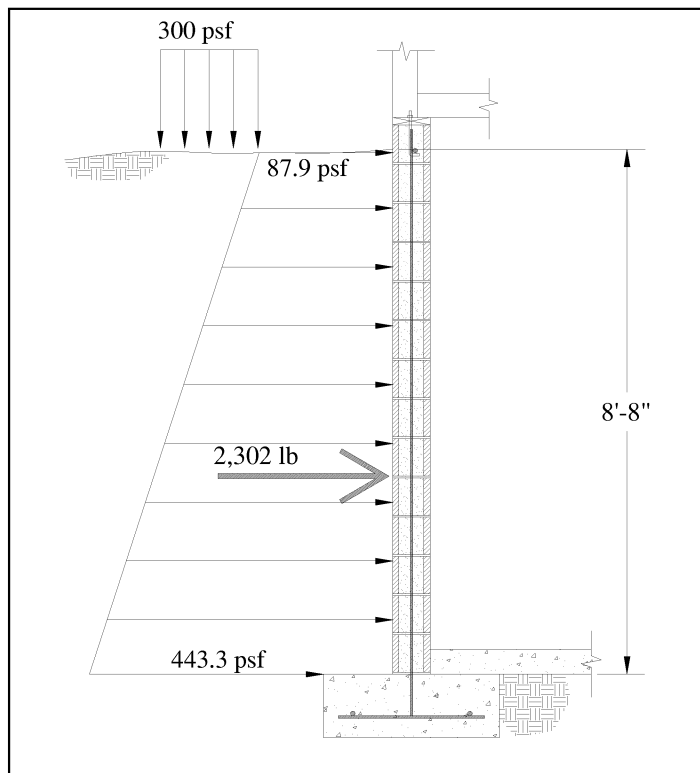
#### 2.2.4.1 Wind

Because foundation walls are typically fully or partially below grade, direct wind pressures on foundation walls seldom control their designs. The action of the superstructure in resisting wind pressure however, can produce compressive, uplift, and shearing or racking loads on foundation walls, which should not be overlooked.

In calculating wind loads on foundation walls, it is usually assumed that the superstructure will act as a unit in resisting wind pressures and in transmitting the wind load to the foundation. Actual wind pressures vary



**Figure 2-5: Equivalent Fluid Pressure Soil Loading**



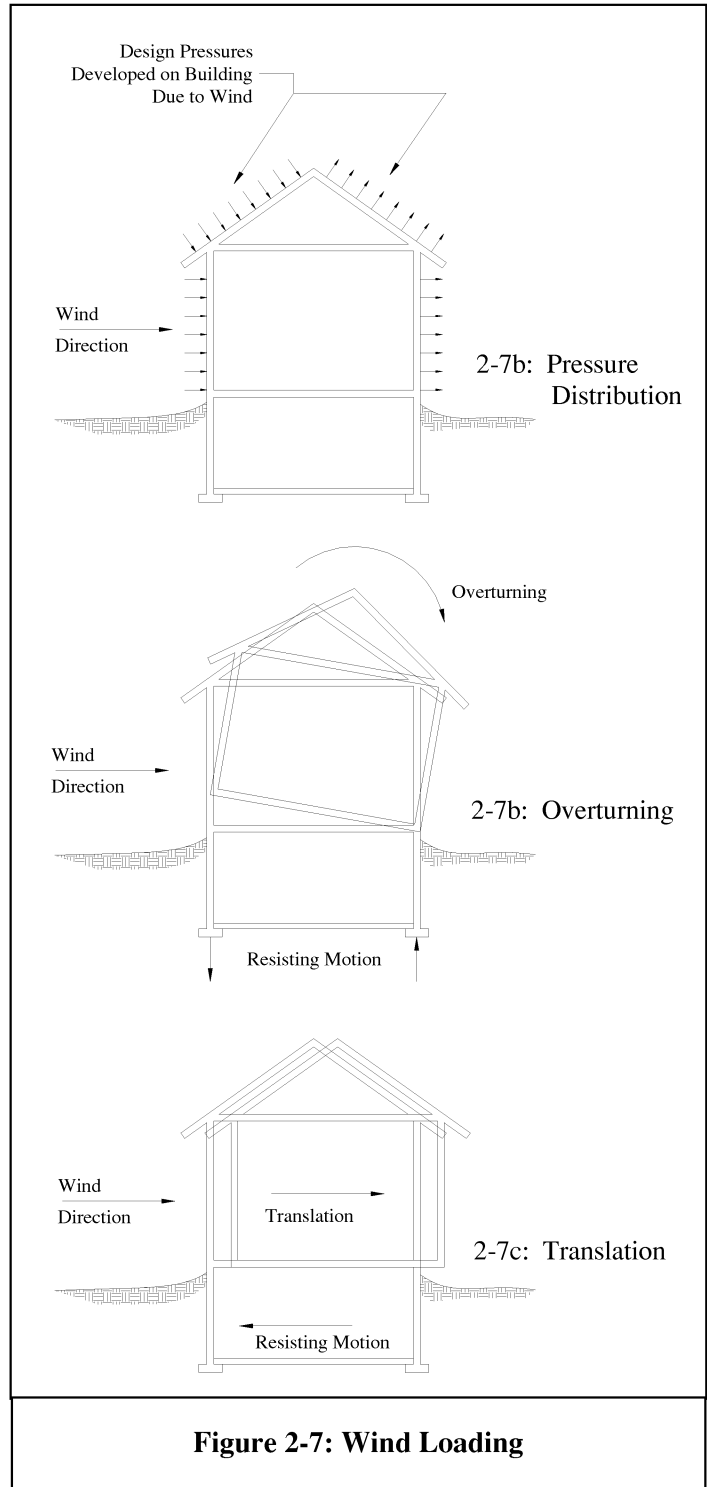
**Figure 2-6: Superimposed Surface Loads**

with wind velocity and the structure's size, shape, orientation, height above ground, and amount of shielding, as well as other factors. As shown in Figure 2-7a, windward walls and slopes of pitched roofs will normally be subjected to positive pressures assumed to act normal (perpendicular) to the surface. Leeward and side walls, the leeward slope of pitched roofs, and flat roofs usually will be subject to negative pressures (suction).

Since any calculation of actual wind pressures involves a number of indeterminate factors which cannot always be eliminated in the design stage, it is customary in building design to substitute an assumed uniformly distributed static lateral pressure for the actual wind pressures when analyzing the overall stability of the structure. The assumed static pressure should allow for both positive pressure on windward side and negative pressure on the leeward side. The design wind load is taken as the resultant of this assumed pressure uniformly distributed over the gross area of the vertical projection of the building elevation perpendicular to the wind flow.

As shown in Figure 2-7b and 2-7c, wind causes overturning and translation of the superstructure with respect to the foundation. In addition, rotation or torsion of the superstructure can be induced for buildings having irregular elevations as shown in building elevation A of Figure 2-8. In the analysis of the loads developed on foundation walls in resisting such movements, it is commonly assumed that the foundation wall perpendicular to the direction of the wind flow resists the overturning moment. This results in increasing the direct vertical

compressive load on the leeward walls and decreasing that on the windward walls. It is further assumed that the force tending to cause translation will be transmitted to the foundation walls parallel to the wind flow



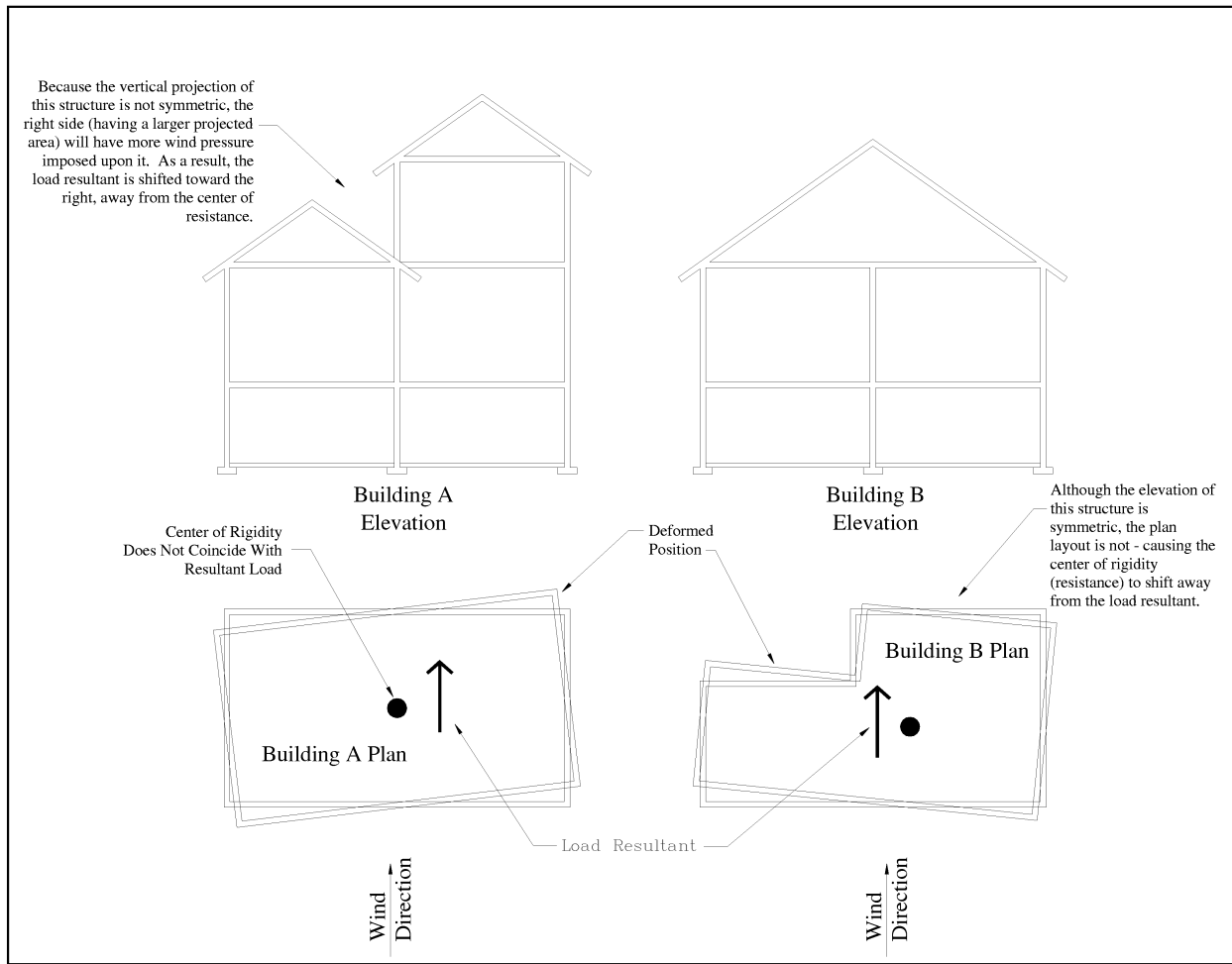
**Figure 2-7: Wind Loading**

by the first floor acting as a diaphragm. This will produce racking or horizontal shearing loads on these walls. As with structures having irregular elevations, structures with irregular plan layouts often have a center of resistance (rigidity) that does not coincide with the line of action of the resultant wind force. As a result, a rotational moment is developed which will affect the distribution of the racking load on the foundation walls as shown in building elevation B of Figure 2-8.

footing. However, the resulting stresses are rarely significant and typically are not computed for conventional residential structures.

Stresses developed in resisting uplift and overturning are seldom critical except in foundations supporting light superstructures subject to high wind pressure. In such cases, the overturning moment may exceed the dead load moment and result in tensile or uplift loads exceeding allowable loads on the windward walls. Accordingly, special attention should be given to providing a direct load path from the roof to the foundation design itself to insure there is adequate uplift capacity. Similarly, high

Theoretically, translation of the superstructure also produces bending in the walls perpendicular to the movement, as illustrated in Figure 2-9 for a fixed base



**Figure 2-8: Rotational Effects of Irregular Building Elevation or Rigidity**

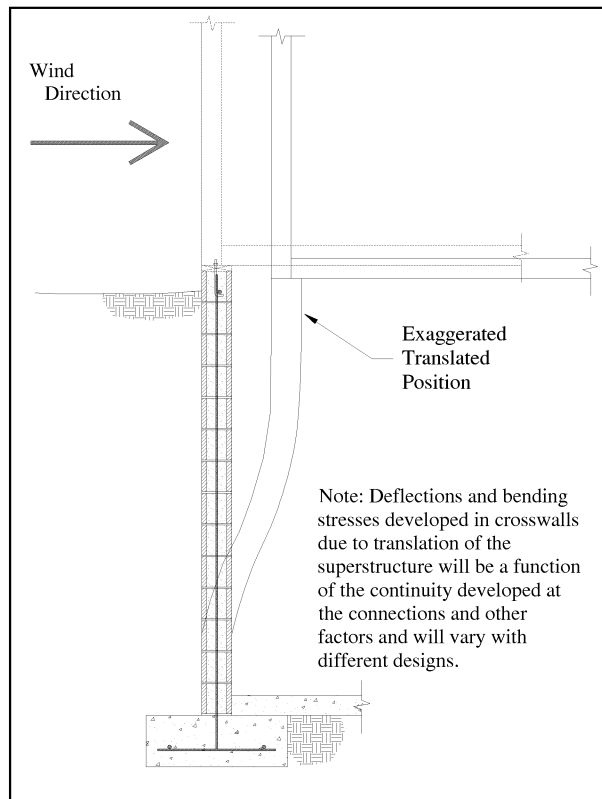
horizontal (in-plane) shearing stresses may be developed in foundations supporting superstructures with a high ratio of exposed area to depth in the direction of the wind flow. In such designs, special attention should be given to the shearing or racking resistance of the walls parallel to the wind flow. Where the floor bearing on the foundation will not have sufficient rigidity to provide diaphragm action, high shear and bending stresses may be expected in the walls normal to the lateral force. In such cases, consideration should be given to the need for interior shear walls, pilasters, or bond beams to stiffen such walls.

#### 2.2.4.2 Blast

Blast forces are similar to wind forces in many respects, since both are aerodynamic (pressure differential) in nature. The principal difference lies in the magnitude and the time duration of the pressures imposed on buildings. Blast forces also impose a surcharge effect on earth pressures acting directly on foundations. Ordinary explosives (non-nuclear) can create pressures far exceeding normal wind pressures for structures located near the blast source. However, the time duration of maximum pressure is so short, usually measured in fractions of a second, that the pressure greatly dissipates before the building can respond or be stressed to failure. For this reason, a static lateral pressure, equal to the average pressure which might be expected at an assumed distance from the blast force, is usually used in design, rather than the maximum pressure. (Ref. 12B)

#### 2.2.5 Earthquake Loads

Over time, the tectonic plates that combine to create the crust of the earth slowly move relative to one another. When this relative movement causes two plates to collide,



**Figure 2-9: Bending Due to Translation**

stresses and strains are generated at the point of contact, or fault line. Once the stresses and strains reach a sufficiently large level, the two plates suddenly slip past one another. This sudden slippage propagates shock waves that pass through the earth, causing movement and vibration of the ground at points far distant from the original source. It is this movement that we term as an earthquake.

Ground motions associated with earthquakes consist of both horizontal (lateral) and vertical ground vibrations. Since the horizontal motion is usually significantly greater and produces the most destructive force, the vertical movements are usually disregarded during the design of most structures. In reality, since the primary loads structures are designed to carry stem from gravity forces that act in the vertical direction, the resulting vertical loading from

earthquakes is typically relatively small compared to the conventional gravity induced loads.

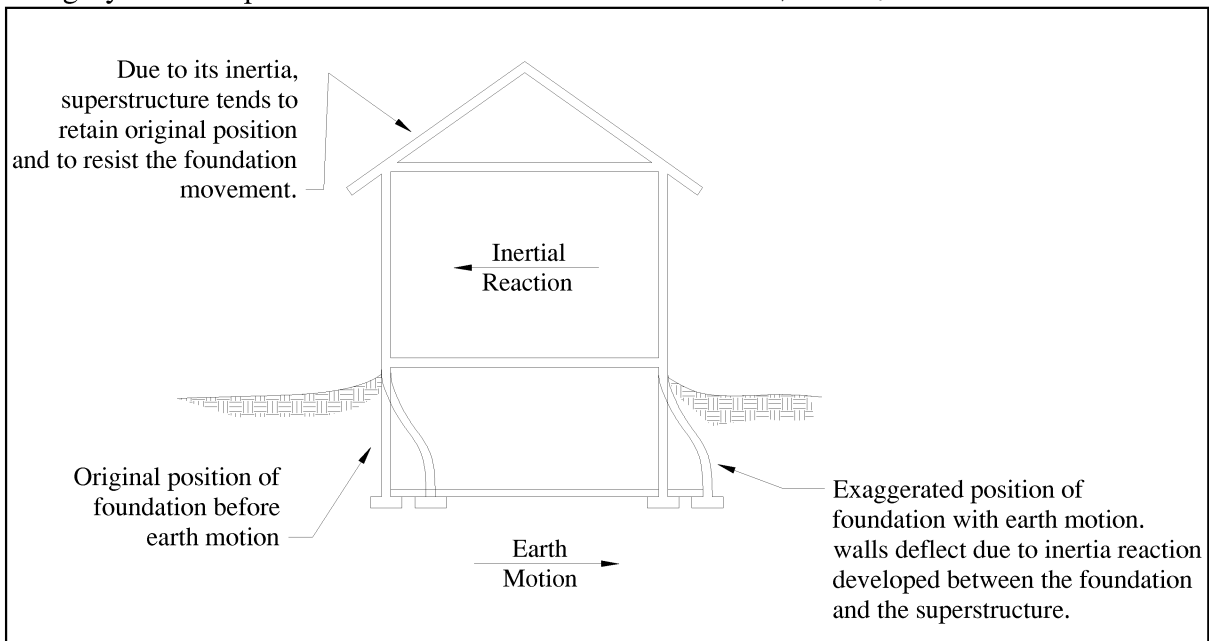
The effect of horizontal ground movements on buildings is illustrated in Figure 2-10. As shown, the building foundation must move with the ground, whereas the superstructure tends to remain at rest in its original position due to inertia. As the foundation displaces, it exerts a force on the superstructure tending to set it in motion. Or conversely, the superstructure exerts a force on the foundation tending to keep it in its original position. The force developed is a function of the acceleration of the horizontal movement and the mass of the superstructure. These two factors, mass and acceleration, have been adopted as direct measures of the force structures are required to resist if subjected to an earthquake.

In accordance with current earthquake design practice, it is customary to assume that the actual reactions produced in a building by an earthquake will be similar to

those resulting from a horizontal static force, acting in any direction on the building as a whole or on each principal mass, such as one story of the building. This method is practical and has been adopted by many building codes (Ref. 6). It has proven quite satisfactory even though it is not an exact measure of the actual forces involved.

Once the design lateral force has been determined, essentially the same methods employed in designing for wind forces may be applied in calculating earthquake stresses. As the direction of the earthquake waves cannot be predetermined (just as with wind), the design load is assumed to act in any direction. Since movements not parallel to the axes of the building can be resolved into components parallel to the axes, it is satisfactory to consider that the force is applied parallel to either of the two horizontal axes of a structure.

As in the case of wind forces, earthquake forces will tend to cause overturning, translation, and/or rotation of the

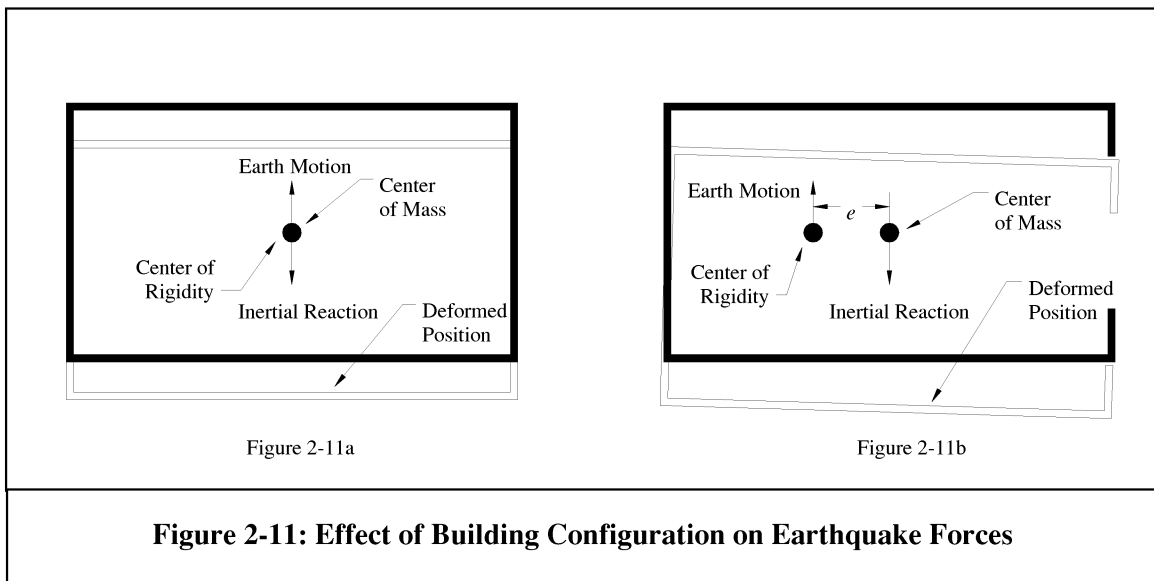


**Figure 2-10: Effect of Earthquake Motion on Foundations**

superstructure with respect to the foundation. (Figures 2-7 and 2-8) As in wind design, the stresses developed in the foundation walls and in the connections between the foundation and the superstructure should be investigated as a result. It should be noted, that whereas wind stresses tend to become more critical as the weight of the construction is decreased in any given design, the reverse is true in the case of earthquake forces. Since the force applied to a structure due to earth movements varies directly with the weight of the structure, stresses due to earthquake forces may become more critical as the weight of the construction is increased. Also, when considering the rotational or torsional effect of earthquake forces, the resultant force will act through the center of mass of the structure, which often does not coincide with the assumed point of application of the resulting earthquake forces. (Figure 2-11) The rotational moment acting on the foundation will be equal to the resultant earthquake force times the distance ( $e$  in Figure 2-11b) from the center of mass of the structure to its center of rigidity, that is, the center of resistance to horizontal translation.

An exaggerated illustration of the effect of earthquake forces in causing rotation is shown in Figure 2-11. Where the center of mass and the center of rigidity coincide, as in Figure 2-11a, no rotational moment is introduced. If however, a portion of one shear wall is removed as in Figure 2-11b, the center of rigidity will become offset from the center of mass and a rotational moment will be introduced. As a result, the wall farthest from the center of rigidity will be deformed and stressed more highly than the wall that is closest to the center of rigidity.

Again, it is assumed that the floor bearing on the foundation acts as a diaphragm in transmitting horizontal shearing forces from the superstructure to the foundation. The overturning will produce compressive and uplift forces on the walls perpendicular to the earth movement. Translation will produce horizontal shearing forces on the parallel walls, and rotation will increase the shearing force in some walls and decrease it in others. The effect of translation in causing bending in walls perpendicular to the direction of loading should be considered where the first floor would not have sufficient rigidity for diaphragm action.





Once the seismic base shear force is determined, it must be distributed into the foundation walls depending on whether the first floor diaphragm is flexible or rigid. For flexible diaphragms, such as typical wood frame floors, the seismic shear force is distributed in proportion to the tributary floor area that each shear wall supports. For example, for a typical rectangular building, 50% of north-south earthquake base shear forces are transmitted to both the east and west building walls.

Rigid diaphragms, by contrast, transmit not only the direct shear force but also torsional forces generated by rotation of the building's center of mass about the center of rigidity. For rigid diaphragms, the foundation walls must resist both the shear and the rotational forces. The magnitude of the shear and rotational forces a wall must carry is directly proportional to the wall's rigidity relative to the rigidity of the other supporting walls. That is, seismic forces are distributed in accordance with the relative stiffness of the supporting elements.

For most small and medium size buildings, concrete masonry foundation shear walls seldom control the design. Because most foundation walls extend around the entire perimeter of a building (and sometimes within the building plan as well), there is typically more than adequate shear wall length to carry the applied seismic shear loads. Connections between the above grade construction and the foundation walls, though, are vital to ensure an adequate transfer of loads.

### **2.2.6 Load Combinations**

Building codes (Ref. 6 and 13) require design loads to be applied to structures in various combinations. These load combinations are intended to account for the combined effects of several load situations

occurring simultaneously. Accordingly, load combinations, such as dead loads plus live loads, must be considered since these loadings may occur at the same time. Extremely improbable load combinations however, (i.e. hurricane force winds occurring at the same time as a severe earthquake) need not be considered as such an analysis would be far too conservative.

As previously discussed, dead and other loads applied axially to a foundation wall counteract the induced flexural tension resulting from lateral soil loads. Therefore, such axial loads can often be ignored when determining the flexural capacity of a given wall. However, such an analysis can result in an over-conservative design. When considering the axial interaction of loads on the flexural capacity of a wall, only dead loads should be considered, as other load types (such as live loads) are not always present. The designer should consider these load combinations carefully to ascertain that the structure is being correctly designed.

### **2.2.7 Load Distribution and Structural Continuity**

Although considerable effort is provided during the design process to ensure that individual elements possess adequate strength or capacity, it is equally as vital to ensure that a continuous load path is created throughout any structure so that applied loads will be transferred from one element, through a connection, to another element, and eventually to the soil through the foundation. This manual includes a number of design tables and details for use by the designer. These tables assume adequate support and connection is provided between the foundation and support structure. The tables also assume the foundation walls are adequately supported at the top by floor or roof diaphragms and at the bottom by footings. The design of these supports

(footings, diaphragms, etc.) however is outside the scope of the manual and must be verified by the designer.

### **2.3 Structural Elements**

As implied throughout this manual, any given structure is generally composed of numerous individual elements; all acting together to resist anticipated loads. Although individual elements are designed separately, they rely upon one another in ensuring that the performance of the overall structure is satisfactory. (This statement becomes apparent in Section 2.2.7 regarding structural continuity.) Although not directly covered in this manual due to the infinite number of combinations of element connections and relative element sizes, the compatibility of individually designed elements should be checked upon completion of the design. In addition to walls, which are the focus of this manual, other structural elements are listed in the following paragraphs.

#### **2.3.1 Pilasters**

Pilasters, or thickened wall sections, may be used to laterally support basement walls and to carry vertical loads from floor beams. They can be designed so that the wall can span either horizontally between pilasters or cross walls or so that the wall can be designed for two-way bending (distributing loads both horizontally and vertically). Either of these alternate design methods may lead to a more economical foundation system than designing the walls to span only in the vertical direction.

Pilasters may be constructed with the same units used in the construction of the wall or with special concrete masonry units. (Figure 8-8) Vertical reinforcing steel is typically added to increase the flexural capacity of the pilaster. When ties enclose the vertical steel, the strength of the

reinforcing steel may also be used to resist compression loads. For additional information on the design and construction of pilasters, refer to Ref. 12C.

#### **2.3.2 Columns**

Unlike pilasters, which are built integrally into a wall, columns are isolated elements whose primary function is to carry vertical axial loads. Since columns are rarely incorporated into foundation construction, their design is not covered in this manual. The user is referred to Ref. 16 for additional information.

#### **2.3.3 Lintels and Beams**

Horizontal structural members known as lintels or beams are used to span openings in concrete masonry walls created by doors and windows. The purpose of these members is to support the weight of the wall above the opening, as well as any additional dead and live loads imposed onto that wall. Although lintels in foundation walls may be precast or cast-in-place concrete or structural steel members, reinforced concrete masonry is often preferred because no special lifting equipment is required and the bond pattern and surface texture of the surrounding masonry is not interrupted.

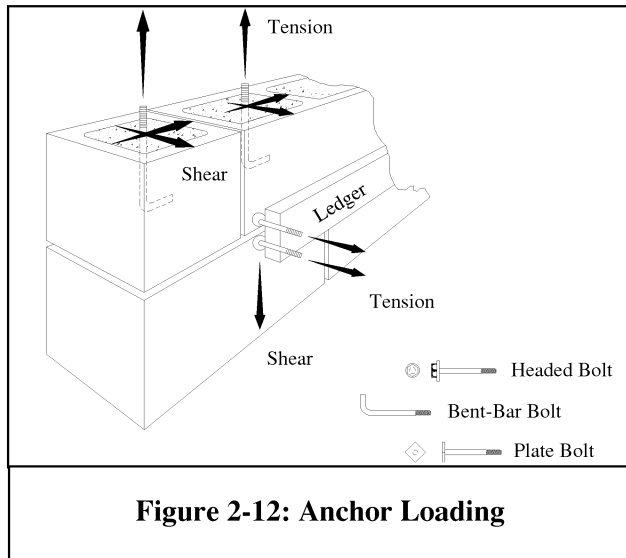
Primarily designed as simply supported beams, lintels are sometimes constructed as a portion of a continuous bond beam course, especially when they occur at the top course of a basement wall.

For additional information on the design of concrete masonry and precast lintels, refer to Ref. 15.

#### **2.3.4 Anchors**

Although anchors are not generally considered a structural element, anchors, and the connections they create, are extremely critical to the overall performance

of a building. The vitality of anchors and connections thus justifies their being covered herein.



The function of anchors is to transfer loads from the masonry to attachments such as ledgers, sill plates, weld plates, etc. Anchors may also be used to transfer loads from these elements into the masonry. Both shear and tension are transferred through anchors to resist design forces such as uplift due to wind or vertical loads on ledgers due to gravity as illustrated in Figure 2-12.

Anchor bolts are generally divided into two categories: embedded anchors, which are placed in grout during construction of the masonry; and post-installed anchors, which are installed after construction of the masonry.

#### 2.3.4.1 Post-Installed Anchors

Post-installed anchors achieve shear and tension (pullout) resistance by means of expansion against the sides of a hole drilled in the masonry, or by bonding with epoxy or other adhesive. Due to the vast number of types and configurations available with post-installed anchors, their design is not covered by any design codes. Therefore, the user

should adhere to manufacturer’s literature when designing with such components.

#### 2.3.4.2 Embedded Anchors

Conventional anchor bolts, which are cast into the masonry during construction, are available in standard sizes (diameters and lengths) or can be fabricated to meet specific project requirements. Anchor bolt types consist of headed bolts, bent bar anchors, and plate anchors.

- Headed bolts are usually either square or hex-headed and are popular due to their wide availability and relatively low cost. Washers may be placed against the bolt head to enlarge the bearing area, thereby increasing pullout resistance.
- Bent bar anchors are currently fabricated in a variety of shapes since no standard exists governing the geometric properties. The “L” and “J” shapes are the most common.
- Plate anchors are fabricated by welding a rectangular or circular steel plate at a right angle to the axis of the bolt. The dimensions of the steel plate (length, width, or diameter) should be at least one inch plus the bolt diameter and the thickness should be at least 5/8 of the bolt diameter.

In new masonry construction, anchor bolts are commonly embedded at:

- Top of walls – to attach sill plates and weld plates to support wood and steel joists, trusses, and beams.
- Top of columns – to attach steel bearing plates to support wood and steel beams.
- Surface of walls – to attach wood or steel ledger beams used to support wood and steel joists and trusses.

To keep the anchor bolts properly aligned during grout placement, the bolts should be tied in place or held within the necessary tolerances using templates.

Based on the design provisions of Reference 8, Tables 2-4 through 2-11 provide allowable axial and shear capacities for common combinations of anchor bolt diameters, embedment lengths, and edge distances. For design configurations other than those covered by Tables 2-4 through 2-11, the anchor bolt design equations for  $B_a$  and  $B_v$  shown in Figure 12-13a can be used.

**Figure 12-13a: Anchor Design**<sup>Ref. 8</sup>

Allowable Tensile Loads

Masonry controlled:

$$B_a = 0.5 A_p \sqrt{f'_m}$$

Steel controlled:

$$B_a = 0.2 A_b f_y$$

Where  $A_p$  shall be the lesser of:

$$A_p = \pi l_b^2$$

$$A_p = \pi l_{be}^2$$

Allowable Shear Loads

Masonry controlled:

$$B_v = 350 \sqrt[4]{f'_m A_b}$$

Steel controlled:

$$B_v = 0.12 A_b f_y$$

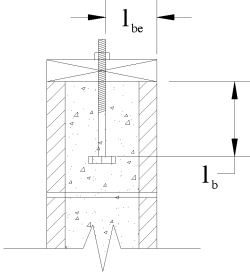
Combined Loads

$$\frac{b_a}{B_a} + \frac{b_v}{B_v} \leq 1$$

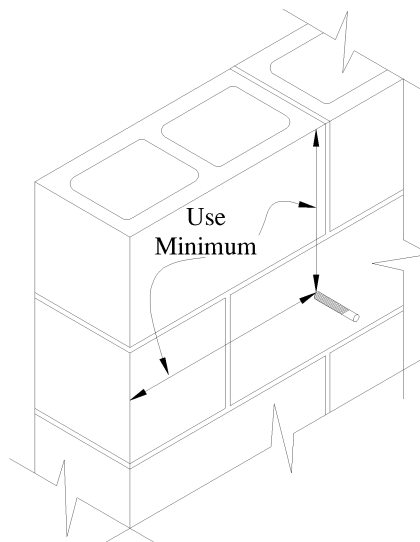
Additional Requirements

1. Where projected areas overlap,  $A_p$  of each bolt shall be reduced by one-half of the overlapping area.
2. Where  $l_{be}$  is less than  $12d_b$ ,  $B_v$  shall be reduced by linear interpolation to zero at an  $l_{be}$  distance of 1 inch.
3. The minimum embedment shall be 2 inches or  $4d_b$ , whichever is greater.

**Figure 2-13b: Anchor Dimensioning**



For anchors embedded in the side of a masonry wall, the edge distance is the minimum distance measured either to the top or the side of the wall.



**Table 2-4: Allowable Axial Capacity,  $B_a$ , of  $1/2$ -inch Anchor Bolts (lb)**

		Anchor Bolt Edge Distance, $l_{be}$ (in.)												
		1.5	2.0	2.5	3.0	3.5	4.0	5.0	6.0	7.0	8.0	9.0	10.0	11.0
Anchor Bolt Embedment, $l_b$ (in.)	3.0	136	243	380	547	547	547	547	547	547	547	547	547	547
	3.5	136	243	380	547	745	745	745	745	745	745	745	745	745
	4.0	136	243	380	547	745	973	973	973	973	973	973	973	973
	4.5	136	243	380	547	745	973	1231	1231	1231	1231	1231	1231	1231
	5.0	136	243	380	547	745	973	1413	1413	1413	1413	1413	1413	1413
	5.5	136	243	380	547	745	973	1413	1413	1413	1413	1413	1413	1413
	6.0	136	243	380	547	745	973	1413	1413	1413	1413	1413	1413	1413
	6.5	136	243	380	547	745	973	1413	1413	1413	1413	1413	1413	1413
	7.0	136	243	380	547	745	973	1413	1413	1413	1413	1413	1413	1413
	7.5	136	243	380	547	745	973	1413	1413	1413	1413	1413	1413	1413
	8.0	136	243	380	547	745	973	1413	1413	1413	1413	1413	1413	1413
	8.5	136	243	380	547	745	973	1413	1413	1413	1413	1413	1413	1413
	9.0	136	243	380	547	745	973	1413	1413	1413	1413	1413	1413	1413
	9.5	136	243	380	547	745	973	1413	1413	1413	1413	1413	1413	1413
10.0	136	243	380	547	745	973	1413	1413	1413	1413	1413	1413	1413	
10.5	136	243	380	547	745	973	1413	1413	1413	1413	1413	1413	1413	
11.0	136	243	380	547	745	973	1413	1413	1413	1413	1413	1413	1413	
11.5	136	243	380	547	745	973	1413	1413	1413	1413	1413	1413	1413	
12.0	136	243	380	547	745	973	1413	1413	1413	1413	1413	1413	1413	

**Table 2-5: Allowable Shear Capacity,  $B_v$ , of  $1/2$ -inch Anchor Bolts (lb)**

		Anchor Bolt Edge Distance, $l_{be}$ (in.)												
		1.5	2.0	2.5	3.0	3.5	4.0	5.0	6.0	7.0	8.0	9.0	10.0	11.0
Anchor Bolt Embedment, $l_b$ (in.)	3.0	144	289	434	579	724	848	848	848	848	848	848	848	848
	3.5	144	289	434	579	724	848	848	848	848	848	848	848	848
	4.0	144	289	434	579	724	848	848	848	848	848	848	848	848
	4.5	144	289	434	579	724	848	848	848	848	848	848	848	848
	5.0	144	289	434	579	724	848	848	848	848	848	848	848	848
	5.5	144	289	434	579	724	848	848	848	848	848	848	848	848
	6.0	144	289	434	579	724	848	848	848	848	848	848	848	848
	6.5	144	289	434	579	724	848	848	848	848	848	848	848	848
	7.0	144	289	434	579	724	848	848	848	848	848	848	848	848
	7.5	144	289	434	579	724	848	848	848	848	848	848	848	848
	8.0	144	289	434	579	724	848	848	848	848	848	848	848	848
	8.5	144	289	434	579	724	848	848	848	848	848	848	848	848
	9.0	144	289	434	579	724	848	848	848	848	848	848	848	848
	9.5	144	289	434	579	724	848	848	848	848	848	848	848	848
10.0	144	289	434	579	724	848	848	848	848	848	848	848	848	
10.5	144	289	434	579	724	848	848	848	848	848	848	848	848	
11.0	144	289	434	579	724	848	848	848	848	848	848	848	848	
11.5	144	289	434	579	724	848	848	848	848	848	848	848	848	
12.0	144	289	434	579	724	848	848	848	848	848	848	848	848	

Notes:

- 1) Values based on the 1999 ACI 530/ASCE 5/TMS 402 (Ref. 8).
- 2) Masonry compressive strength,  $f'_m = 1,500$  psi.
- 3) Anchor bolt yield strength,  $f_y = 36,000$  psi.
- 4) Anchor bolt spacing must be greater than the lesser of  $2l_{be}$  or  $l_b$ .

**Table 2-6: Allowable Axial Capacity,  $B_a$ , of  $5/8$ -inch Anchor Bolts (lb)**

		Anchor Bolt Edge Distance, $l_{be}$ (in.)												
		1.5	2.0	2.5	3.0	3.5	4.0	5.0	6.0	7.0	8.0	9.0	10.0	11.0
Anchor Bolt Embedment, $l_b$ (in.)	3.0	136	243	380	547	547	547	547	547	547	547	547	547	547
	3.5	136	243	380	547	745	745	745	745	745	745	745	745	745
	4.0	136	243	380	547	745	973	973	973	973	973	973	973	973
	4.5	136	243	380	547	745	973	1231	1231	1231	1231	1231	1231	1231
	5.0	136	243	380	547	745	973	1520	1520	1520	1520	1520	1520	1520
	5.5	136	243	380	547	745	973	1520	1840	1840	1840	1840	1840	1840
	6.0	136	243	380	547	745	973	1520	2190	2190	2190	2190	2190	2190
	6.5	136	243	380	547	745	973	1520	2190	2208	2208	2208	2208	2208
	7.0	136	243	380	547	745	973	1520	2190	2208	2208	2208	2208	2208
	7.5	136	243	380	547	745	973	1520	2190	2208	2208	2208	2208	2208
	8.0	136	243	380	547	745	973	1520	2190	2208	2208	2208	2208	2208
	8.5	136	243	380	547	745	973	1520	2190	2208	2208	2208	2208	2208
	9.0	136	243	380	547	745	973	1520	2190	2208	2208	2208	2208	2208
	9.5	136	243	380	547	745	973	1520	2190	2208	2208	2208	2208	2208
	10.0	136	243	380	547	745	973	1520	2190	2208	2208	2208	2208	2208
10.5	136	243	380	547	745	973	1520	2190	2208	2208	2208	2208	2208	
11.0	136	243	380	547	745	973	1520	2190	2208	2208	2208	2208	2208	
11.5	136	243	380	547	745	973	1520	2190	2208	2208	2208	2208	2208	
12.0	136	243	380	547	745	973	1520	2190	2208	2208	2208	2208	2208	

**Table 2-7: Allowable Shear Capacity,  $B_v$ , of  $5/8$ -inch Anchor Bolts (lb)**

		Anchor Bolt Edge Distance, $l_{be}$ (in.)												
		1.5	2.0	2.5	3.0	3.5	4.0	5.0	6.0	7.0	8.0	9.0	10.0	11.0
Anchor Bolt Embedment, $l_b$ (in.)	3.0	124	249	374	498	623	748	997	1246	1325	1325	1325	1325	1325
	3.5	124	249	374	498	623	748	997	1246	1325	1325	1325	1325	1325
	4.0	124	249	374	498	623	748	997	1246	1325	1325	1325	1325	1325
	4.5	124	249	374	498	623	748	997	1246	1325	1325	1325	1325	1325
	5.0	124	249	374	498	623	748	997	1246	1325	1325	1325	1325	1325
	5.5	124	249	374	498	623	748	997	1246	1325	1325	1325	1325	1325
	6.0	124	249	374	498	623	748	997	1246	1325	1325	1325	1325	1325
	6.5	124	249	374	498	623	748	997	1246	1325	1325	1325	1325	1325
	7.0	124	249	374	498	623	748	997	1246	1325	1325	1325	1325	1325
	7.5	124	249	374	498	623	748	997	1246	1325	1325	1325	1325	1325
	8.0	124	249	374	498	623	748	997	1246	1325	1325	1325	1325	1325
	8.5	124	249	374	498	623	748	997	1246	1325	1325	1325	1325	1325
	9.0	124	249	374	498	623	748	997	1246	1325	1325	1325	1325	1325
	9.5	124	249	374	498	623	748	997	1246	1325	1325	1325	1325	1325
	10.0	124	249	374	498	623	748	997	1246	1325	1325	1325	1325	1325
10.5	124	249	374	498	623	748	997	1246	1325	1325	1325	1325	1325	
11.0	124	249	374	498	623	748	997	1246	1325	1325	1325	1325	1325	
11.5	124	249	374	498	623	748	997	1246	1325	1325	1325	1325	1325	
12.0	124	249	374	498	623	748	997	1246	1325	1325	1325	1325	1325	

Notes:

- 1) Values based on the 1999 ACI 530/ASCE 5/TMS 402 (Ref. 8).
- 2) Masonry compressive strength,  $f'_m = 1,500$  psi.
- 3) Anchor bolt yield strength,  $f_y = 36,000$  psi.
- 4) Anchor bolt spacing must be greater than the lesser of  $2l_{be}$  or  $l_b$ .

**Table 2-8: Allowable Axial Capacity,  $B_a$ , of  $3/4$ -inch Anchor Bolts (lb)**

		Anchor Bolt Edge Distance, $l_{be}$ (in.)												
		1.5	2.0	2.5	3.0	3.5	4.0	5.0	6.0	7.0	8.0	9.0	10.0	11.0
Anchor Bolt Embedment, $l_b$ (in.)	3.0	136	243	380	547	547	547	547	547	547	547	547	547	547
	3.5	136	243	380	547	745	745	745	745	745	745	745	745	745
	4.0	136	243	380	547	745	973	973	973	973	973	973	973	973
	4.5	136	243	380	547	745	973	1231	1231	1231	1231	1231	1231	1231
	5.0	136	243	380	547	745	973	1520	1520	1520	1520	1520	1520	1520
	5.5	136	243	380	547	745	973	1520	1840	1840	1840	1840	1840	1840
	6.0	136	243	380	547	745	973	1520	2190	2190	2190	2190	2190	2190
	6.5	136	243	380	547	745	973	1520	2190	2570	2570	2570	2570	2570
	7.0	136	243	380	547	745	973	1520	2190	2980	2980	2980	2980	2980
	7.5	136	243	380	547	745	973	1520	2190	2980	3180	3180	3180	3180
	8.0	136	243	380	547	745	973	1520	2190	2980	3180	3180	3180	3180
	8.5	136	243	380	547	745	973	1520	2190	2980	3180	3180	3180	3180
	9.0	136	243	380	547	745	973	1520	2190	2980	3180	3180	3180	3180
	9.5	136	243	380	547	745	973	1520	2190	2980	3180	3180	3180	3180
	10.0	136	243	380	547	745	973	1520	2190	2980	3180	3180	3180	3180
10.5	136	243	380	547	745	973	1520	2190	2980	3180	3180	3180	3180	
11.0	136	243	380	547	745	973	1520	2190	2980	3180	3180	3180	3180	
11.5	136	243	380	547	745	973	1520	2190	2980	3180	3180	3180	3180	
12.0	136	243	380	547	745	973	1520	2190	2980	3180	3180	3180	3180	

**Table 2-9: Allowable Shear Capacity,  $B_v$ , of  $3/4$ -inch Anchor Bolts (lb)**

		Anchor Bolt Edge Distance, $l_{be}$ (in.)												
		1.5	2.0	2.5	3.0	3.5	4.0	5.0	6.0	7.0	8.0	9.0	10.0	11.0
Anchor Bolt Embedment, $l_b$ (in.)	3.0	110	221	332	443	554	665	887	1109	1331	1553	1775	1775	1775
	3.5	110	221	332	443	554	665	887	1109	1331	1553	1775	1775	1775
	4.0	110	221	332	443	554	665	887	1109	1331	1553	1775	1775	1775
	4.5	110	221	332	443	554	665	887	1109	1331	1553	1775	1775	1775
	5.0	110	221	332	443	554	665	887	1109	1331	1553	1775	1775	1775
	5.5	110	221	332	443	554	665	887	1109	1331	1553	1775	1775	1775
	6.0	110	221	332	443	554	665	887	1109	1331	1553	1775	1775	1775
	6.5	110	221	332	443	554	665	887	1109	1331	1553	1775	1775	1775
	7.0	110	221	332	443	554	665	887	1109	1331	1553	1775	1775	1775
	7.5	110	221	332	443	554	665	887	1109	1331	1553	1775	1775	1775
	8.0	110	221	332	443	554	665	887	1109	1331	1553	1775	1775	1775
	8.5	110	221	332	443	554	665	887	1109	1331	1553	1775	1775	1775
	9.0	110	221	332	443	554	665	887	1109	1331	1553	1775	1775	1775
	9.5	110	221	332	443	554	665	887	1109	1331	1553	1775	1775	1775
	10.0	110	221	332	443	554	665	887	1109	1331	1553	1775	1775	1775
10.5	110	221	332	443	554	665	887	1109	1331	1553	1775	1775	1775	
11.0	110	221	332	443	554	665	887	1109	1331	1553	1775	1775	1775	
11.5	110	221	332	443	554	665	887	1109	1331	1553	1775	1775	1775	
12.0	110	221	332	443	554	665	887	1109	1331	1553	1775	1775	1775	

Notes:

- 1) Values based on the 1999 ACI 530/ASCE 5/TMS 402 (Ref. 8).
- 2) Masonry compressive strength,  $f'_m = 1,500$  psi.
- 3) Anchor bolt yield strength,  $f_y = 36,000$  psi.
- 4) Anchor bolt spacing must be greater than the lesser of  $2l_{be}$  or  $l_b$ .

**Table 2-10: Allowable Axial Capacity,  $B_a$ , of  $7/8$ -inch Anchor Bolts (lb)**

		Anchor Bolt Edge Distance, $l_{be}$ (in.)												
		1.5	2.0	2.5	3.0	3.5	4.0	5.0	6.0	7.0	8.0	9.0	10.0	11.0
Anchor Bolt Embedment, $l_b$ (in.)	3.0	NP	NP	NP	NP	NP	NP	NP	NP	NP	NP	NP	NP	NP
	3.5	136	243	380	547	745	745	745	745	745	745	745	745	745
	4.0	136	243	380	547	745	973	973	973	973	973	973	973	973
	4.5	136	243	380	547	745	973	1231	1231	1231	1231	1231	1231	1231
	5.0	136	243	380	547	745	973	1520	1520	1520	1520	1520	1520	1520
	5.5	136	243	380	547	745	973	1520	1840	1840	1840	1840	1840	1840
	6.0	136	243	380	547	745	973	1520	2190	2190	2190	2190	2190	2190
	6.5	136	243	380	547	745	973	1520	2190	2570	2570	2570	2570	2570
	7.0	136	243	380	547	745	973	1520	2190	2980	2980	2980	2980	2980
	7.5	136	243	380	547	745	973	1520	2190	2980	3422	3422	3422	3422
	8.0	136	243	380	547	745	973	1520	2190	2980	3893	3893	3893	3893
	8.5	136	243	380	547	745	973	1520	2190	2980	3893	4329	4329	4329
	9.0	136	243	380	547	745	973	1520	2190	2980	3893	4329	4329	4329
	9.5	136	243	380	547	745	973	1520	2190	2980	3893	4329	4329	4329
	10.0	136	243	380	547	745	973	1520	2190	2980	3893	4329	4329	4329
10.5	136	243	380	547	745	973	1520	2190	2980	3893	4329	4329	4329	
11.0	136	243	380	547	745	973	1520	2190	2980	3893	4329	4329	4329	
11.5	136	243	380	547	745	973	1520	2190	2980	3893	4329	4329	4329	
12.0	136	243	380	547	745	973	1520	2190	2980	3893	4329	4329	4329	

**Table 2-11: Allowable Shear Capacity,  $B_v$ , of  $7/8$ -inch Anchor Bolts (lb)**

		Anchor Bolt Edge Distance, $l_{be}$ (in.)												
		1.5	2.0	2.5	3.0	3.5	4.0	5.0	6.0	7.0	8.0	9.0	10.0	11.0
Anchor Bolt Embedment, $l_b$ (in.)	3.0	NP	NP	NP	NP	NP	NP	NP	NP	NP	NP	NP	NP	NP
	3.5	100	201	302	403	504	605	807	1009	1211	1413	1615	1817	1918
	4.0	100	201	302	403	504	605	807	1009	1211	1413	1615	1817	1918
	4.5	100	201	302	403	504	605	807	1009	1211	1413	1615	1817	1918
	5.0	100	201	302	403	504	605	807	1009	1211	1413	1615	1817	1918
	5.5	100	201	302	403	504	605	807	1009	1211	1413	1615	1817	1918
	6.0	100	201	302	403	504	605	807	1009	1211	1413	1615	1817	1918
	6.5	100	201	302	403	504	605	807	1009	1211	1413	1615	1817	1918
	7.0	100	201	302	403	504	605	807	1009	1211	1413	1615	1817	1918
	7.5	100	201	302	403	504	605	807	1009	1211	1413	1615	1817	1918
	8.0	100	201	302	403	504	605	807	1009	1211	1413	1615	1817	1918
	8.5	100	201	302	403	504	605	807	1009	1211	1413	1615	1817	1918
	9.0	100	201	302	403	504	605	807	1009	1211	1413	1615	1817	1918
	9.5	100	201	302	403	504	605	807	1009	1211	1413	1615	1817	1918
	10.0	100	201	302	403	504	605	807	1009	1211	1413	1615	1817	1918
10.5	100	201	302	403	504	605	807	1009	1211	1413	1615	1817	1918	
11.0	100	201	302	403	504	605	807	1009	1211	1413	1615	1817	1918	
11.5	100	201	302	403	504	605	807	1009	1211	1413	1615	1817	1918	
12.0	100	201	302	403	504	605	807	1009	1211	1413	1615	1817	1918	

Notes:

- 1) Values based on the 1999 ACI 530/ASCE 5/TMS 402 (Ref. 8).
- 2) Masonry compressive strength,  $f'_m = 1,500$  psi.
- 3) Anchor bolt yield strength,  $f_y = 36,000$  psi.
- 4) Anchor bolt spacing must be greater than the lesser of  $2l_{be}$  or  $l_b$ .



## **2.4 Bending Moments and Shear Forces**

Bending moments and shear forces develop in foundation walls due to the application of lateral loads and eccentric axial loads. Although there are a variety of design methods and assumptions regarding structural mechanics available to the designer, only those pertaining to the design of foundations are presented here.

As critical to the choice and application of the anticipated loads, the method of supporting an element (and hence how the element distributes the applied load) can significantly impact the magnitude of the loads that can be carried. Three of the most common support conditions when considering foundation designs are: simply supported, fixed, and free.

### ***2.4.1 Simply Supported Elements***

For ease of design, basement walls are commonly considered to span vertically between the first floor diaphragm and the basement slab or footing – neglecting the transference of loads horizontally to end walls, returns, or pilasters. Often, this method further assumes the wall is simply supported (pinned-pinned) at both the top and bottom, again simplifying the design. It should be noted that some connection details might provide some degree of fixity at the supports. Neglecting partial fixity at a support cannot, in general, be said to be

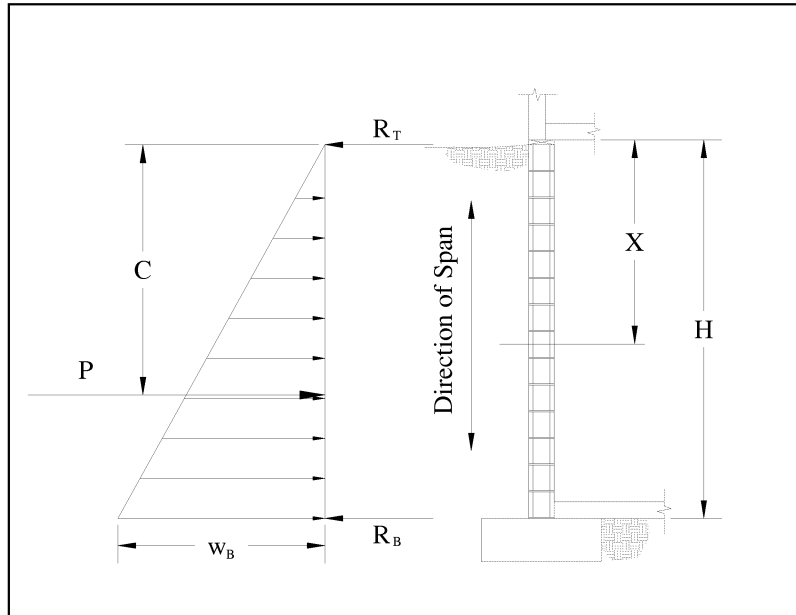
either conservative or non-conservative. However, for most residential foundation designs, when taking into account factors such as the degree of redundancy inherent in the overall structure combined with the relative properties of common construction materials (i.e., wood versus masonry), does not typically make simple supports a detrimental assumption.

For applications where it is assumed that the foundation wall is simply supported and spanning vertically, Figures 2-14a through 2-14d can be used to determine the maximum resulting bending moment and shear for a given circumstance. (Generally, only the maximum anticipated bending moment and shear are calculated at a critical section of an element. The entire length of an element is then designed to carry the maximum resulting stresses.) As outlined previously in this chapter, the earth pressures assumed in Figures 2-14a through 2-14d (as well as all other similar figures in this manual) were calculated by the equivalent fluid pressure method.

Where construction circumstances allow, design bending moments and shears have been computed for common construction configurations. Tables 2-12 through 2-18 list the maximum shear and bending moment for the design equations summarized in Figure 2-14b.

**Figure 2-14a: Triangular Loading on a Simply Supported Wall**

- $\Delta$  = soil density (lb/ft<sup>3</sup>)
- $K$  = coefficient of lateral earth pressure ( $K_a$  or  $K_o$ )
- $X$  = distance from top of wall (ft)
- $E_m$  = modulus of elasticity of masonry (lb/in<sup>2</sup>)
- $I_n$  = moment of inertia of masonry assemblage (in<sup>4</sup> per foot length of wall)
- $H$  = height of wall (ft)
- $C$  = distance to total lateral load from top of wall (ft)  
 $C = \frac{2H}{3}$



Load at base of wall,  $w_B$  (lb/ft per foot length of wall):  
 $w_B = \rho K H$

Total lateral load applied to wall,  $P$  (lb per foot length of wall):  
 $P = \frac{1}{2} w_B H = \frac{1}{2} \rho K H^2$

Reaction at top of wall,  $R_T$  (lb per foot length of wall):  
 $R_T = \frac{1}{6} \rho K H^2$

Reaction at bottom of wall,  $R_B$  (lb) and maximum shear,  $V_{max}$  (lb per foot length of wall):  
 $V_{max} = R_B = \frac{1}{3} \rho K H^2$

Location of maximum shear,  $X_{Vmax}$  (ft):  
 $X_{Vmax} = H$

Maximum bending moment,  $M_{max}$  (ft-lb per foot length of wall):  
 $M_{max} = \frac{\rho K H^3}{9\sqrt{3}} = \frac{w_B H^2}{9\sqrt{3}}$

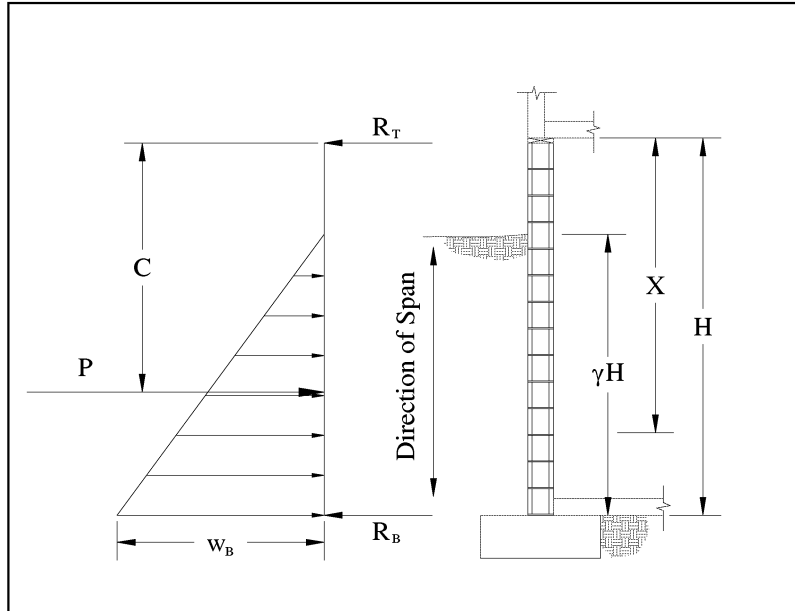
Location of maximum bending moment,  $X_{Mmax}$  (ft):  
 $X_{Mmax} = \frac{H}{\sqrt{3}}$

Maximum deflection,  $\Delta_{max}$  (in):  
 $\Delta_{max} = \frac{0.006522 w_B H^4}{E_m I_n} (1728 \text{ in}^3 / \text{ft}^3)$

Location of maximum deflection,  $X_{\Delta max}$  (ft):  
 $X_{\Delta max} = 0.519H$

**Figure 2-14b: Partial Triangular Loading on a Simply Supported Wall**

- $\rho$  = soil density (lb/ft<sup>3</sup>)
- $K$  = coefficient of lateral earth pressure ( $K_a$  or  $K_o$ )
- $X$  = distance from top of wall (ft)
- $E_m$  = modulus of elasticity of masonry (lb/in<sup>2</sup>)
- $I_n$  = moment of inertia of masonry assemblage (in<sup>4</sup> per foot length of wall)
- $H$  = height of wall (ft)
- $\gamma$  = ratio of height of backfill to total height of wall



Distance from top of wall to total lateral load,  $C$  (ft):

$$C = H - \frac{1}{3}\gamma H$$

Load at base of wall,  $w_B$  (lb/ft per foot length of wall):

$$w_B = \rho K \gamma H$$

Total lateral load applied to wall,  $P$  (lb per foot length of wall):

$$P = \frac{1}{2} w_B \gamma H = \frac{1}{2} \rho K (\gamma H)^2$$

Reaction at top of wall,  $R_T$  (lb per foot length of wall):

$$R_T = \frac{1}{6} \rho K \gamma^3 H^2 = \frac{1}{3} P \gamma$$

Reaction at bottom of wall,  $R_B$  (lb) and maximum shear,  $V_{max}$  (lb per foot length of wall):

$$V_{max} = R_B = \frac{1}{2} \rho K (\gamma H)^2 - \frac{1}{6} \rho K \gamma^3 H^2 = P \left( 1 - \frac{\gamma}{3} \right)$$

Location of maximum shear,  $X_{V_{max}}$  (ft):

$$X_{V_{max}} = H$$

Maximum bending moment,  $M_{max}$  (ft-lb per foot length of wall):

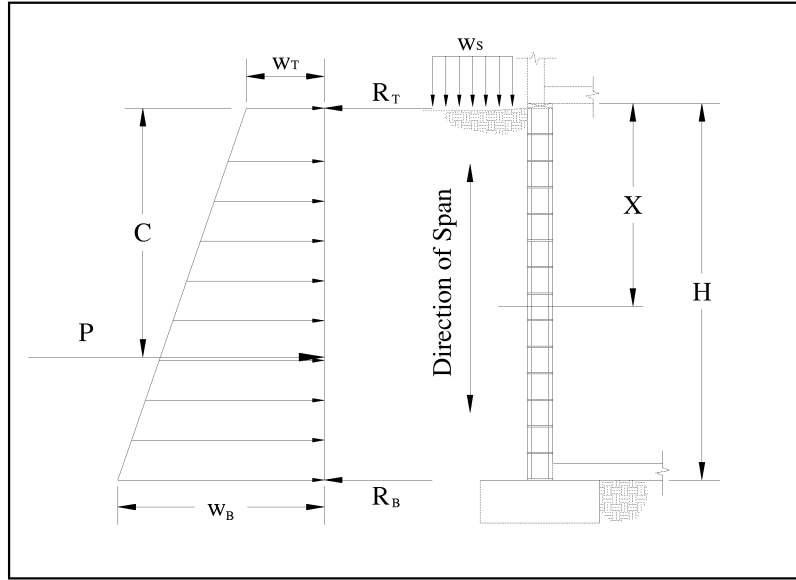
$$M_{max} = \left( \frac{1}{6} w_B (\gamma H)^2 \right) \left( 1 - \gamma + \frac{2\gamma}{3} \sqrt{\frac{\gamma}{3}} \right)$$

Location of maximum bending moment,  $X_{M_{max}}$  (ft):

$$X_{M_{max}} = H(1 - \gamma) + \gamma H \sqrt{\frac{\gamma}{3}}$$

**Figure 2-14c: Triangular Loading on a Simply Supported Wall with Nearby Surcharge Loading**

- $\Delta$  = soil density (lb/ft<sup>3</sup>)
- $K$  = coefficient of lateral earth pressure ( $K_a$  or  $K_o$ )
- $X$  = distance from top of wall (ft)
- $E_m$  = modulus of elasticity of masonry (lb/in<sup>2</sup>)
- $I_n$  = moment of inertia of masonry assemblage (in<sup>4</sup> per foot length of wall)
- $H$  = height of wall (ft)
- $w_s$  = surcharge load (psf)



Distance from top of wall to total lateral load,  $C$  (ft):

$$C = H/12 \left( \frac{2w_B + w_T}{w_B + w_T} \right)$$

Load at top of wall,  $w_T$  (lb/ft per foot length of wall):

$$w_T = K w_s$$

Load at base of wall,  $w_B$  (lb/ft per foot length of wall):

$$w_B = \rho K H + w_T$$

Total lateral load applied to wall,  $P$  (lb per foot length of wall):

$$P = H/2 (w_B + w_T)$$

Reaction at top of wall,  $R_T$  (lb per foot length of wall):

$$R_T = H/6 (2w_T + w_B)$$

Reaction at bottom of wall,  $R_B$  (lb) and maximum shear,  $V_{max}$  (lb per foot length of wall):

$$V_{max} = R_B = H/6 (2w_B + w_T)$$

Location of maximum shear,  $X_{Vmax}$  (ft):

$$X_{Vmax} = H$$

Maximum bending moment,  $M_{max}$  (ft-lb per foot length of wall):

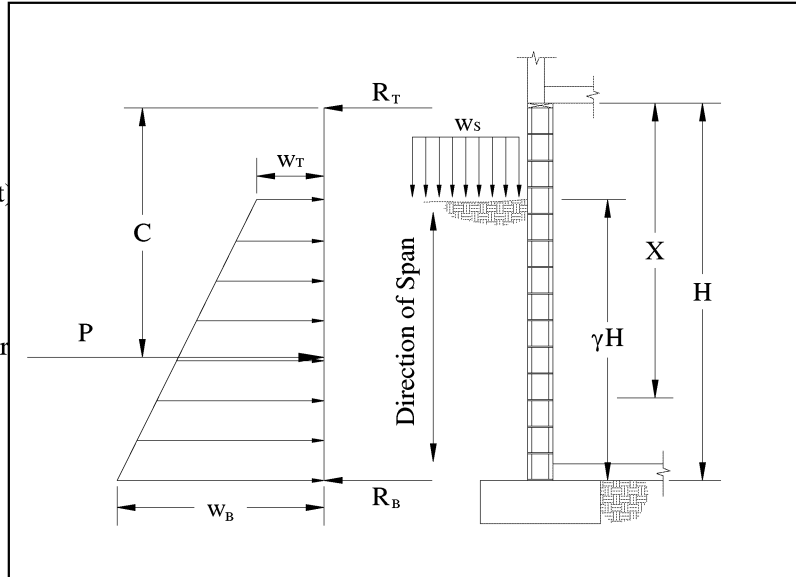
$$M_{max} = 0.0642H^2 (w_B + 0.92w_T)$$

Location of maximum bending moment,  $X_{Mmax}$  (ft):

$$X_{Mmax} = 0.56H$$

**Figure 2-14d: Partial Triangular Loading on a Simply Supported Wall with Nearby Surcharge Loading**

- $\rho$  = soil density (lb/ft<sup>3</sup>)
- $K$  = coefficient of lateral earth pressure ( $K_a$  or  $K_o$ )
- $X$  = distance from top of wall (ft)
- $E_m$  = modulus of elasticity of masonry (lb/in<sup>2</sup>)
- $I_n$  = moment of inertia of masonry assemblage (in<sup>4</sup> per foot length of wall)
- $H$  = height of wall (ft)
- $\gamma$  = ratio of height of backfill to total height of wall
- $w_s$  = surcharge load (psf)



Distance from top of wall to total lateral load,  $C$  (ft):

$$C = H \left( 1 - \frac{\gamma}{3} \right)$$

Load at base of wall,  $w_B$  (lb/ft per foot length of wall):

$$w_B = \rho K h + K w_s$$

Total lateral load applied to wall,  $P$  (lb per foot length of wall):

$$P = \frac{1}{2} \gamma H (w_B + w_T)$$

Reaction at top of wall,  $R_T$  (lb per foot length of wall):

$$R_T = \frac{h^2}{6H} (w_B + 2w_T)$$

Reaction at bottom of wall,  $R_B$  (lb) and maximum shear,  $V_{max}$  (lb per foot length of wall):

$$V_{max} = R_B = \frac{1}{2} (\gamma H) \left( w_B + w_T - \frac{1}{3} \gamma (w_B + 2w_T) \right)$$

Location of maximum shear,  $X_{Vmax}$  (ft):

$$X_{Vmax} = H$$

Maximum bending moment,  $M_{max}$  (ft-lb per foot length of wall):

$$M_{max} = \frac{1}{h} (w_B - w_T) \left( 0.5hC^2H^2 - \frac{1}{6}C^3H^3 \right) + 0.5w_T C^2H^2 - R_B CH$$

where  $C = 0.29$

Location of maximum bending moment,  $X_{Mmax}$  (ft):

$$X_{Mmax} = 0.70H$$

**Table 2-12a: Maximum Moment (ft-lb per linear foot of wall) for Simply Supported  
End Conditions With a Triangular Load to the Top of the Wall**

Wall Height (ft-in.)	Maximum Moment (ft-lb/ft) for an Equivalent Fluid Pressure (lb/ft <sup>2</sup> /ft) of:									
	30	35	40	45	50	60	75	95	105	120
4'-0"	123	144	164	185	205	246	308	390	431	493
4'-8"	196	228	261	293	326	391	489	619	685	782
5'-4"	292	341	389	438	487	584	730	925	1,022	1,168
6'-0"	416	485	554	624	693	831	1,039	1,316	1,455	1,663
6'-8"	570	665	760	855	950	1,140	1,426	1,806	1,996	2,281
7'-4"	759	885	1,012	1,138	1,265	1,518	1,897	2,403	2,656	3,036
8'-0"	985	1,150	1,314	1,478	1,642	1,971	2,463	3,120	3,449	3,941
8'-8"	1,253	1,462	1,670	1,879	2,088	2,506	3,132	3,967	4,385	5,011
9'-4"	1,565	1,825	2,086	2,347	2,608	3,129	3,912	4,955	5,476	6,259
10'-0"	1,925	2,245	2,566	2,887	3,208	3,849	4,811	6,094	6,736	7,698
10'-8"	2,336	2,725	3,114	3,503	3,893	4,671	5,839	7,396	8,175	9,343
11'-4"	2,802	3,268	3,735	4,202	4,669	5,603	7,004	8,871	9,805	11,206
12'-0"	3,326	3,880	4,434	4,988	5,543	6,651	8,314	10,531	11,639	13,302
12'-8"	3,911	4,563	5,215	5,867	6,519	7,822	9,778	12,385	13,689	15,645
13'-4"	4,562	5,322	6,082	6,843	7,603	9,124	11,404	14,446	15,966	18,247
14'-0"	5,281	6,161	7,041	7,921	8,801	10,562	13,202	16,723	18,483	21,123
14'-8"	6,072	7,084	8,096	9,108	10,120	12,143	15,179	19,227	21,251	24,287
15'-4"	6,938	8,094	9,251	10,407	11,563	13,876	17,345	21,970	24,283	27,752
16'-0"	7,883	9,197	10,510	11,824	13,138	15,766	19,707	24,962	27,590	31,531
16'-8"	8,910	10,395	11,880	13,365	14,850	17,819	22,274	28,214	31,184	35,639

**Table 2-12b: Maximum Shear Force (lb per linear foot of wall) for Simply Supported  
End Conditions With a Triangular Load to the Top of the Wall**

Wall Height (ft-in.)	Maximum Shear Force (lb/ft) for an Equivalent Fluid Pressure (lb/ft <sup>2</sup> /ft) of:									
	30	35	40	45	50	60	75	95	105	120
4'-0"	160	187	213	240	267	320	400	507	560	640
4'-8"	218	254	290	327	363	436	544	690	762	871
5'-4"	284	332	379	427	474	569	711	901	996	1,138
6'-0"	360	420	480	540	600	720	900	1,140	1,260	1,440
6'-8"	444	519	593	667	741	889	1,111	1,407	1,556	1,778
7'-4"	538	627	717	807	896	1,076	1,344	1,703	1,882	2,151
8'-0"	640	747	853	960	1,067	1,280	1,600	2,027	2,240	2,560
8'-8"	751	876	1,001	1,127	1,252	1,502	1,878	2,379	2,629	3,004
9'-4"	871	1,016	1,161	1,307	1,452	1,742	2,178	2,759	3,049	3,484
10'-0"	1,000	1,167	1,333	1,500	1,667	2,000	2,500	3,167	3,500	4,000
10'-8"	1,138	1,327	1,517	1,707	1,896	2,276	2,844	3,603	3,982	4,551
11'-4"	1,284	1,499	1,713	1,927	2,141	2,569	3,211	4,067	4,496	5,138
12'-0"	1,440	1,680	1,920	2,160	2,400	2,880	3,600	4,560	5,040	5,760
12'-8"	1,604	1,872	2,139	2,407	2,674	3,209	4,011	5,081	5,616	6,418
13'-4"	1,778	2,074	2,370	2,667	2,963	3,556	4,444	5,630	6,222	7,111
14'-0"	1,960	2,287	2,613	2,940	3,267	3,920	4,900	6,207	6,860	7,840
14'-8"	2,151	2,510	2,868	3,227	3,585	4,302	5,378	6,812	7,529	8,604
15'-4"	2,351	2,743	3,135	3,527	3,919	4,702	5,878	7,445	8,229	9,404
16'-0"	2,560	2,987	3,413	3,840	4,267	5,120	6,400	8,107	8,960	10,240
16'-8"	2,778	3,241	3,704	4,167	4,630	5,556	6,944	8,796	9,722	11,111

**Table 2-13a: Maximum Moment (ft-lb per linear foot of wall) for Simply Supported  
End Conditions With a Triangular Load to 0.9H**

Wall Height (ft-in.)	Maximum Moment (ft-lb/ft) for an Equivalent Fluid Pressure (lb/ft <sup>2</sup> /ft) of:									
	30	35	40	45	50	60	75	95	105	120
4'-0"	100	117	133	150	167	200	250	317	350	400
4'-8"	159	185	212	238	265	318	397	503	556	635
5'-4"	237	277	316	356	395	474	593	751	830	948
6'-0"	337	394	450	506	562	675	844	1,069	1,181	1,350
6'-8"	463	540	617	694	772	926	1,157	1,466	1,620	1,852
7'-4"	616	719	822	924	1,027	1,232	1,540	1,951	2,157	2,465
8'-0"	800	933	1,067	1,200	1,333	1,600	2,000	2,533	2,800	3,200
8'-8"	1,017	1,187	1,356	1,526	1,695	2,034	2,543	3,221	3,560	4,068
9'-4"	1,270	1,482	1,694	1,905	2,117	2,541	3,176	4,023	4,446	5,081
10'-0"	1,562	1,823	2,083	2,344	2,604	3,125	3,906	4,948	5,468	6,249
10'-8"	1,896	2,212	2,528	2,844	3,160	3,792	4,740	6,004	6,636	7,585
11'-4"	2,274	2,653	3,032	3,412	3,791	4,549	5,686	7,202	7,960	9,097
12'-0"	2,700	3,150	3,600	4,050	4,500	5,400	6,749	8,549	9,449	10,799
12'-8"	3,175	3,704	4,234	4,763	5,292	6,350	7,938	10,055	11,113	12,701
13'-4"	3,703	4,321	4,938	5,555	6,172	7,407	9,258	11,727	12,962	14,814
14'-0"	4,287	5,002	5,716	6,431	7,145	8,574	10,718	13,576	15,005	17,149
14'-8"	4,929	5,751	6,572	7,394	8,215	9,858	12,323	15,609	17,252	19,717
15'-4"	5,632	6,571	7,510	8,449	9,387	11,265	14,081	17,836	19,713	22,530
16'-0"	6,399	7,466	8,533	9,599	10,666	12,799	15,999	20,265	22,398	25,598
16'-8"	7,233	8,439	9,644	10,850	12,055	14,466	18,083	22,905	25,316	28,933

**Table 2-13b: Maximum Shear Force (lb per linear foot of wall) for Simply Supported  
End Conditions With a Triangular Load to 0.9H**

Wall Height (ft-in.)	Maximum Shear Force (lb/ft) for an Equivalent Fluid Pressure (lb/ft <sup>2</sup> /ft) of:									
	30	35	40	45	50	60	75	95	105	120
4'-0"	136	159	181	204	227	272	340	431	476	544
4'-8"	185	216	247	278	309	370	463	587	648	741
5'-4"	242	282	323	363	403	484	605	766	847	968
6'-0"	306	357	408	459	510	612	765	970	1,072	1,225
6'-8"	378	441	504	567	630	756	945	1,197	1,323	1,512
7'-4"	457	534	610	686	762	915	1,143	1,448	1,601	1,830
8'-0"	544	635	726	816	907	1,089	1,361	1,724	1,905	2,177
8'-8"	639	745	852	958	1,065	1,278	1,597	2,023	2,236	2,555
9'-4"	741	864	988	1,111	1,235	1,482	1,852	2,346	2,593	2,964
10'-0"	851	992	1,134	1,276	1,418	1,701	2,126	2,693	2,977	3,402
10'-8"	968	1,129	1,290	1,452	1,613	1,935	2,419	3,064	3,387	3,871
11'-4"	1,092	1,274	1,457	1,639	1,821	2,185	2,731	3,459	3,823	4,370
12'-0"	1,225	1,429	1,633	1,837	2,041	2,449	3,062	3,878	4,287	4,899
12'-8"	1,365	1,592	1,819	2,047	2,274	2,729	3,411	4,321	4,776	5,458
13'-4"	1,512	1,764	2,016	2,268	2,520	3,024	3,780	4,788	5,292	6,048
14'-0"	1,667	1,945	2,223	2,500	2,778	3,334	4,167	5,279	5,834	6,668
14'-8"	1,830	2,134	2,439	2,744	3,049	3,659	4,574	5,793	6,403	7,318
15'-4"	2,000	2,333	2,666	2,999	3,333	3,999	4,999	6,332	6,999	7,998
16'-0"	2,177	2,540	2,903	3,266	3,629	4,355	5,443	6,895	7,620	8,709
16'-8"	2,363	2,756	3,150	3,544	3,938	4,725	5,906	7,481	8,269	9,450

**Table 2-14a: Maximum Moment (ft-lb per linear foot of wall) for Simply Supported  
End Conditions With a Triangular Load to 0.8H**

Wall Height (ft-in.)	Maximum Moment (-lb/ft) for an Equivalent Fluid Pressure (lb/ft <sup>2</sup> /ft) of:									
	30	35	40	45	50	60	75	95	105	120
4'-0"	78	91	104	117	130	156	195	247	273	312
4'-8"	124	144	165	186	206	247	309	392	433	495
5'-4"	185	215	246	277	308	369	462	585	646	739
6'-0"	263	307	351	394	438	526	657	832	920	1,052
6'-8"	361	421	481	541	601	721	902	1,142	1,262	1,442
7'-4"	480	560	640	720	800	960	1,200	1,520	1,680	1,920
8'-0"	623	727	831	935	1,039	1,246	1,558	1,973	2,181	2,493
8'-8"	792	924	1,056	1,188	1,320	1,585	1,981	2,509	2,773	3,169
9'-4"	990	1,154	1,319	1,484	1,649	1,979	2,474	3,133	3,463	3,958
10'-0"	1,217	1,420	1,623	1,826	2,028	2,434	3,043	3,854	4,260	4,868
10'-8"	1,477	1,723	1,969	2,216	2,462	2,954	3,693	4,677	5,170	5,908
11'-4"	1,772	2,067	2,362	2,658	2,953	3,543	4,429	5,610	6,201	7,087
12'-0"	2,103	2,454	2,804	3,155	3,505	4,206	5,258	6,660	7,361	8,412
12'-8"	2,473	2,886	3,298	3,710	4,122	4,947	6,184	7,832	8,657	9,894
13'-4"	2,885	3,366	3,846	4,327	4,808	5,770	7,212	9,135	10,097	11,539
14'-0"	3,340	3,896	4,453	5,009	5,566	6,679	8,349	10,575	11,689	13,358
14'-8"	3,840	4,480	5,120	5,760	6,400	7,680	9,599	12,159	13,439	15,359
15'-4"	4,388	5,119	5,850	6,581	7,313	8,775	10,969	13,894	15,356	17,550
16'-0"	4,985	5,816	6,647	7,478	8,308	9,970	12,463	15,786	17,448	19,940
16'-8"	5,635	6,574	7,513	8,452	9,391	11,269	14,086	17,843	19,721	22,538

**Table 2-14b: Maximum Shear Force (lb per linear foot of wall) for Simply Supported  
End Conditions With a Triangular Load to 0.8H**

Wall Height (ft-in.)	Maximum Shear Force (lb/ft) for an Equivalent Fluid Pressure (lb/ft <sup>2</sup> /ft) of:									
	30	35	40	45	50	60	75	95	105	120
4'-0"	113	131	150	169	188	225	282	357	394	451
4'-8"	153	179	204	230	256	307	383	485	537	613
5'-4"	200	234	267	300	334	400	501	634	701	801
6'-0"	253	296	338	380	422	507	634	803	887	1,014
6'-8"	313	365	417	469	521	626	782	991	1,095	1,252
7'-4"	379	442	505	568	631	757	946	1,199	1,325	1,514
8'-0"	451	526	601	676	751	901	1,126	1,427	1,577	1,802
8'-8"	529	617	705	793	881	1,058	1,322	1,674	1,851	2,115
9'-4"	613	715	818	920	1,022	1,227	1,533	1,942	2,146	2,453
10'-0"	704	821	939	1,056	1,173	1,408	1,760	2,229	2,464	2,816
10'-8"	801	934	1,068	1,201	1,335	1,602	2,002	2,536	2,803	3,204
11'-4"	904	1,055	1,206	1,356	1,507	1,808	2,261	2,863	3,165	3,617
12'-0"	1,014	1,183	1,352	1,521	1,690	2,028	2,534	3,210	3,548	4,055
12'-8"	1,130	1,318	1,506	1,694	1,883	2,259	2,824	3,577	3,953	4,518
13'-4"	1,252	1,460	1,669	1,877	2,086	2,503	3,129	3,963	4,380	5,006
14'-0"	1,380	1,610	1,840	2,070	2,300	2,760	3,450	4,369	4,829	5,519
14'-8"	1,514	1,767	2,019	2,272	2,524	3,029	3,786	4,796	5,300	6,058
15'-4"	1,655	1,931	2,207	2,483	2,759	3,310	4,138	5,241	5,793	6,621
16'-0"	1,802	2,103	2,403	2,703	3,004	3,604	4,506	5,707	6,308	7,209
16'-8"	1,956	2,281	2,607	2,933	3,259	3,911	4,889	6,193	6,844	7,822



**Table 2-15a: Maximum Moment (ft-lb per linear foot of wall) for Simply Supported  
End Conditions With a Triangular Load to 0.7H**

Wall Height (ft-in.)	Maximum Moment (ft-lb/ft) for an Equivalent Fluid Pressure (lb/ft <sup>2</sup> /ft) of:									
	30	35	40	45	50	60	75	95	105	120
4'-0"	58	67	77	87	96	115	144	183	202	231
4'-8"	92	107	122	137	153	183	229	290	321	366
5'-4"	137	159	182	205	228	273	342	433	478	547
6'-0"	195	227	260	292	324	389	487	616	681	779
6'-8"	267	311	356	400	445	534	667	845	934	1,068
7'-4"	355	415	474	533	592	711	888	1,125	1,244	1,421
8'-0"	461	538	615	692	769	923	1,153	1,461	1,615	1,845
8'-8"	587	684	782	880	978	1,173	1,466	1,858	2,053	2,346
9'-4"	733	855	977	1,099	1,221	1,465	1,832	2,320	2,564	2,931
10'-0"	901	1,051	1,201	1,352	1,502	1,802	2,253	2,853	3,154	3,604
10'-8"	1,094	1,276	1,458	1,640	1,823	2,187	2,734	3,463	3,828	4,374
11'-4"	1,312	1,530	1,749	1,968	2,186	2,623	3,279	4,154	4,591	5,247
12'-0"	1,557	1,817	2,076	2,336	2,595	3,114	3,893	4,931	5,450	6,228
12'-8"	1,831	2,137	2,442	2,747	3,052	3,663	4,578	5,799	6,410	7,325
13'-4"	2,136	2,492	2,848	3,204	3,560	4,272	5,340	6,764	7,476	8,544
14'-0"	2,473	2,885	3,297	3,709	4,121	4,945	6,182	7,830	8,654	9,890
14'-8"	2,843	3,317	3,791	4,264	4,738	5,686	7,107	9,003	9,950	11,372
15'-4"	3,248	3,790	4,331	4,873	5,414	6,497	8,121	10,287	11,370	12,994
16'-0"	3,691	4,306	4,921	5,536	6,151	7,382	9,227	11,688	12,918	14,764
16'-8"	4,172	4,867	5,562	6,258	6,953	8,343	10,429	13,211	14,601	16,687

**Table 2-15b: Maximum Shear Force (lb per linear foot of wall) for Simply Supported  
End Conditions With a Triangular Load to 0.7H**

Wall Height (ft-in.)	Maximum Shear Force (lb/ft) for an Equivalent Fluid Pressure (lb/ft <sup>2</sup> /ft) of:									
	30	35	40	45	50	60	75	95	105	120
4'-0"	90	105	120	135	150	180	225	286	316	361
4'-8"	123	143	164	184	205	245	307	389	430	491
5'-4"	160	187	214	240	267	321	401	508	561	641
6'-0"	203	237	270	304	338	406	507	642	710	811
6'-8"	250	292	334	376	417	501	626	793	877	1,002
7'-4"	303	354	404	455	505	606	758	960	1,061	1,212
8'-0"	361	421	481	541	601	721	902	1,142	1,262	1,443
8'-8"	423	494	564	635	705	847	1,058	1,340	1,481	1,693
9'-4"	491	573	654	736	818	982	1,227	1,554	1,718	1,963
10'-0"	564	657	751	845	939	1,127	1,409	1,784	1,972	2,254
10'-8"	641	748	855	962	1,069	1,282	1,603	2,030	2,244	2,565
11'-4"	724	844	965	1,086	1,206	1,448	1,809	2,292	2,533	2,895
12'-0"	811	947	1,082	1,217	1,352	1,623	2,029	2,570	2,840	3,246
12'-8"	904	1,055	1,205	1,356	1,507	1,808	2,260	2,863	3,164	3,616
13'-4"	1,002	1,169	1,336	1,503	1,670	2,004	2,504	3,172	3,506	4,007
14'-0"	1,104	1,289	1,473	1,657	1,841	2,209	2,761	3,497	3,866	4,418
14'-8"	1,212	1,414	1,616	1,818	2,020	2,424	3,030	3,838	4,243	4,849
15'-4"	1,325	1,546	1,766	1,987	2,208	2,650	3,312	4,195	4,637	5,299
16'-0"	1,443	1,683	1,923	2,164	2,404	2,885	3,606	4,568	5,049	5,770
16'-8"	1,565	1,826	2,087	2,348	2,609	3,131	3,913	4,957	5,478	6,261

**Table 2-16a: Maximum Moment (ft-lb per linear foot of wall) for Simply Supported  
End Conditions With a Triangular Load to 0.6H**

Wall Height (ft-in.)	Maximum Moment (ft-lb/ft) for an Equivalent Fluid Pressure (lb/ft <sup>2</sup> /ft) of:									
	30	35	40	45	50	60	75	95	105	120
4'-0"	40	47	53	60	67	80	100	127	140	160
4'-8"	64	74	85	95	106	127	159	201	222	254
5'-4"	95	111	126	142	158	190	237	300	332	379
6'-0"	135	158	180	203	225	270	338	428	473	540
6'-8"	185	216	247	278	309	370	463	587	648	741
7'-4"	247	288	329	370	411	493	616	781	863	986
8'-0"	320	373	427	480	534	640	800	1,014	1,120	1,280
8'-8"	407	475	543	610	678	814	1,017	1,289	1,424	1,628
9'-4"	508	593	678	762	847	1,017	1,271	1,610	1,779	2,033
10'-0"	625	729	834	938	1,042	1,250	1,563	1,980	2,188	2,501
10'-8"	759	885	1,012	1,138	1,265	1,518	1,897	2,403	2,656	3,035
11'-4"	910	1,062	1,213	1,365	1,517	1,820	2,275	2,882	3,185	3,640
12'-0"	1,080	1,260	1,440	1,621	1,801	2,161	2,701	3,421	3,781	4,321
12'-8"	1,271	1,482	1,694	1,906	2,118	2,541	3,176	4,024	4,447	5,082
13'-4"	1,482	1,729	1,976	2,223	2,470	2,964	3,705	4,693	5,187	5,928
14'-0"	1,716	2,001	2,287	2,573	2,859	3,431	4,289	5,433	6,004	6,862
14'-8"	1,972	2,301	2,630	2,959	3,287	3,945	4,931	6,246	6,904	7,890
15'-4"	2,254	2,629	3,005	3,381	3,756	4,508	5,635	7,137	7,888	9,015
16'-0"	2,561	2,988	3,414	3,841	4,268	5,122	6,402	8,109	8,963	10,243
16'-8"	2,894	3,377	3,859	4,342	4,824	5,789	7,236	9,166	10,130	11,578

**Table 2-16b: Maximum Shear Force (lb per linear foot of wall) for Simply Supported  
End Conditions With a Triangular Load to 0.6H**

Wall Height (ft-in.)	Maximum Shear Force (lb/ft) for an Equivalent Fluid Pressure (lb/ft <sup>2</sup> /ft) of:									
	30	35	40	45	50	60	75	95	105	120
4'-0"	69	81	92	104	115	138	173	219	242	276
4'-8"	94	110	125	141	157	188	235	298	329	376
5'-4"	123	143	164	184	205	246	307	389	430	492
6'-0"	156	181	207	233	259	311	389	492	544	622
6'-8"	192	224	256	288	320	384	480	608	672	768
7'-4"	232	271	310	348	387	465	581	736	813	929
8'-0"	276	323	369	415	461	553	691	876	968	1,106
8'-8"	324	379	433	487	541	649	811	1,028	1,136	1,298
9'-4"	376	439	502	564	627	753	941	1,192	1,317	1,505
10'-0"	432	504	576	648	720	864	1,080	1,368	1,512	1,728
10'-8"	492	573	655	737	819	983	1,229	1,556	1,720	1,966
11'-4"	555	647	740	832	925	1,110	1,387	1,757	1,942	2,220
12'-0"	622	726	829	933	1,037	1,244	1,555	1,970	2,177	2,488
12'-8"	693	809	924	1,040	1,155	1,386	1,733	2,195	2,426	2,772
13'-4"	768	896	1,024	1,152	1,280	1,536	1,920	2,432	2,688	3,072
14'-0"	847	988	1,129	1,270	1,411	1,693	2,117	2,681	2,964	3,387
14'-8"	929	1,084	1,239	1,394	1,549	1,859	2,323	2,943	3,252	3,717
15'-4"	1,016	1,185	1,354	1,524	1,693	2,031	2,539	3,216	3,555	4,063
16'-0"	1,106	1,290	1,475	1,659	1,843	2,212	2,765	3,502	3,871	4,424
16'-8"	1,200	1,400	1,600	1,800	2,000	2,400	3,000	3,800	4,200	4,800

**Table 2-17a: Maximum Moment (ft-lb per linear foot of wall) for Simply Supported  
End Conditions With a Triangular Load to 0.5H**

Wall Height (ft-in.)	Maximum Moment (ft-lb/ft) for an Equivalent Fluid Pressure (lb/ft <sup>2</sup> /ft) of:									
	30	35	40	45	50	60	75	95	105	120
4'-0"	25	30	34	38	42	51	64	81	89	102
4'-8"	40	47	54	61	67	81	101	128	141	162
5'-4"	60	70	80	90	101	121	151	191	211	241
6'-0"	86	100	114	129	143	172	215	272	301	343
6'-8"	118	137	157	177	196	236	294	373	412	471
7'-4"	157	183	209	235	261	314	392	496	549	627
8'-0"	204	237	271	305	339	407	509	645	712	814
8'-8"	259	302	345	388	431	518	647	820	906	1,035
9'-4"	323	377	431	485	539	646	808	1,024	1,131	1,293
10'-0"	398	464	530	596	663	795	994	1,259	1,391	1,590
10'-8"	482	563	643	724	804	965	1,206	1,528	1,689	1,930
11'-4"	579	675	772	868	965	1,157	1,447	1,833	2,026	2,315
12'-0"	687	801	916	1,030	1,145	1,374	1,717	2,175	2,404	2,748
12'-8"	808	943	1,077	1,212	1,347	1,616	2,020	2,558	2,828	3,232
13'-4"	942	1,099	1,256	1,414	1,571	1,885	2,356	2,984	3,298	3,769
14'-0"	1,091	1,273	1,455	1,636	1,818	2,182	2,727	3,454	3,818	4,364
14'-8"	1,254	1,463	1,672	1,881	2,090	2,509	3,136	3,972	4,390	5,017
15'-4"	1,433	1,672	1,911	2,150	2,389	2,866	3,583	4,538	5,016	5,733
16'-0"	1,628	1,900	2,171	2,443	2,714	3,257	4,071	5,157	5,699	6,513
16'-8"	1,841	2,147	2,454	2,761	3,068	3,681	4,601	5,828	6,442	7,362

**Table 2-17b: Maximum Shear Force (lb per linear foot of wall) for Simply Supported  
End Conditions With a Triangular Load to 0.5H**

Wall Height (ft-in.)	Maximum Shear Force (lb/ft) for an Equivalent Fluid Pressure (lb/ft <sup>2</sup> /ft) of:									
	30	35	40	45	50	60	75	95	105	120
4'-0"	50	58	67	75	83	100	125	158	175	200
4'-8"	68	79	91	102	113	136	170	216	238	272
5'-4"	89	104	119	133	148	178	222	281	311	356
6'-0"	113	131	150	169	188	225	281	356	394	450
6'-8"	139	162	185	208	231	278	347	440	486	556
7'-4"	168	196	224	252	280	336	420	532	588	672
8'-0"	200	233	267	300	333	400	500	633	700	800
8'-8"	235	274	313	352	391	469	587	743	822	939
9'-4"	272	318	363	408	454	544	681	862	953	1,089
10'-0"	313	365	417	469	521	625	781	990	1,094	1,250
10'-8"	356	415	474	533	593	711	889	1,126	1,244	1,422
11'-4"	401	468	535	602	669	803	1,003	1,271	1,405	1,606
12'-0"	450	525	600	675	750	900	1,125	1,425	1,575	1,800
12'-8"	501	585	669	752	836	1,003	1,253	1,588	1,755	2,006
13'-4"	556	648	741	833	926	1,111	1,389	1,759	1,944	2,222
14'-0"	613	715	817	919	1,021	1,225	1,531	1,940	2,144	2,450
14'-8"	672	784	896	1,008	1,120	1,344	1,681	2,129	2,353	2,689
15'-4"	735	857	980	1,102	1,225	1,469	1,837	2,327	2,572	2,939
16'-0"	800	933	1,067	1,200	1,333	1,600	2,000	2,533	2,800	3,200
16'-8"	868	1,013	1,157	1,302	1,447	1,736	2,170	2,749	3,038	3,472

**Table 2-18a: Maximum Moment (ft-lb per linear foot of wall) for Simply Supported  
End Conditions With a Triangular Load to 0.4H**

Wall Height (ft-in.)	Maximum Moment (ft-lb/ft) for an Equivalent Fluid Pressure (lb/ft <sup>2</sup> /ft) of:									
	30	35	40	45	50	60	75	95	105	120
4'-0"	14	17	19	21	24	29	36	45	50	57
4'-8"	23	26	30	34	38	45	57	72	79	91
5'-4"	34	39	45	51	56	68	85	107	118	135
6'-0"	48	56	64	72	80	96	121	153	169	193
6'-8"	66	77	88	99	110	132	165	209	231	264
7'-4"	88	103	117	132	147	176	220	279	308	352
8'-0"	114	133	152	171	190	229	286	362	400	457
8'-8"	145	169	194	218	242	291	363	460	508	581
9'-4"	181	212	242	272	302	363	454	575	635	726
10'-0"	223	260	298	335	372	446	558	707	781	893
10'-8"	271	316	361	406	451	542	677	858	948	1,083
11'-4"	325	379	433	487	541	650	812	1,029	1,137	1,299
12'-0"	386	450	514	578	643	771	964	1,221	1,350	1,542
12'-8"	454	529	605	680	756	907	1,134	1,436	1,587	1,814
13'-4"	529	617	705	793	882	1,058	1,322	1,675	1,851	2,116
14'-0"	612	714	816	919	1,021	1,225	1,531	1,939	2,143	2,449
14'-8"	704	821	939	1,056	1,173	1,408	1,760	2,230	2,464	2,816
15'-4"	804	939	1,073	1,207	1,341	1,609	2,011	2,548	2,816	3,218
16'-0"	914	1,066	1,219	1,371	1,523	1,828	2,285	2,895	3,199	3,656
16'-8"	1,033	1,205	1,378	1,550	1,722	2,066	2,583	3,272	3,616	4,133

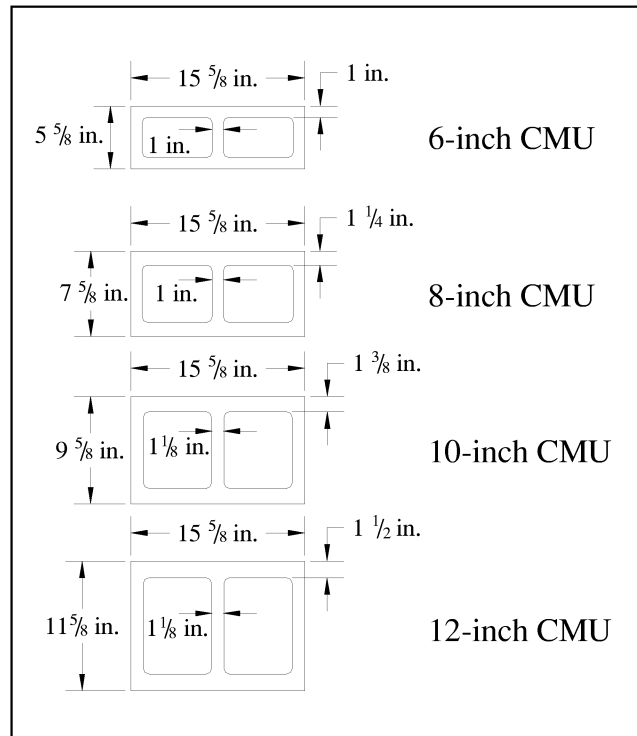
**Table 2-18b: Maximum Shear Force (lb per linear foot of wall) for Simply Supported  
End Conditions With a Triangular Load to 0.4H**

Wall Height (ft-in.)	Maximum Shear Force (lb/ft) for an Equivalent Fluid Pressure (lb/ft <sup>2</sup> /ft) of:									
	30	35	40	45	50	60	75	95	105	120
4'-0"	33	39	44	50	55	67	83	105	116	133
4'-8"	45	53	60	68	75	91	113	143	159	181
5'-4"	59	69	79	89	99	118	148	187	207	237
6'-0"	75	87	100	112	125	150	187	237	262	300
6'-8"	92	108	123	139	154	185	231	293	324	370
7'-4"	112	131	149	168	186	224	280	354	392	447
8'-0"	133	155	177	200	222	266	333	422	466	532
8'-8"	156	182	208	234	260	312	391	495	547	625
9'-4"	181	211	242	272	302	362	453	574	634	725
10'-0"	208	243	277	312	347	416	520	659	728	832
10'-8"	237	276	316	355	394	473	592	749	828	947
11'-4"	267	312	356	401	445	534	668	846	935	1,069
12'-0"	300	349	399	449	499	599	749	948	1,048	1,198
12'-8"	334	389	445	501	556	667	834	1,057	1,168	1,335
13'-4"	370	431	493	555	616	740	924	1,171	1,294	1,479
14'-0"	408	476	544	612	679	815	1,019	1,291	1,427	1,631
14'-8"	447	522	597	671	746	895	1,119	1,417	1,566	1,790
15'-4"	489	571	652	734	815	978	1,223	1,549	1,712	1,956
16'-0"	532	621	710	799	887	1,065	1,331	1,686	1,864	2,130
16'-8"	578	674	770	867	963	1,156	1,444	1,830	2,022	2,311

## 2.5 Section Properties

Section properties and wall weights for grouted and ungrouted single wythe concrete masonry walls are included in this section. The properties shown in Tables 2-19 through 2-22 are based on minimum face shell and web thickness requirements of ASTM Specification C 90 (Ref. 5A). These dimensions are illustrated in Figure 2-15 for the hollow units assumed in determining these values. The wall weights provided assume a mortar density of 125 pcf, a grout density of 140 pcf, and varying unit densities.

In determining section properties, the walls are assumed to span vertically, that is, the moment of inertia and the section modulus were calculated assuming bending about a horizontal axis parallel to the plane of the masonry. The net section properties shown ( $A_n$ ,  $I_n$ ,  $S_n$ , and  $r_n$ ) are calculated based on the net cross-sectional area through a typical mortar bed joint. These values are typically related to the critical section when determining stresses due to an applied load. In addition, average sectional properties are provided ( $A_{avg}$ ,  $I_{avg}$ ,  $S_{avg}$ , and  $r_{avg}$ ). These values correspond to the average section properties of the wall – and not the critical section. Therefore, their use is predominantly limited to determining stiffness or deflections due to an applied loading.



**Figure 2-15: Specified Block Dimensions**

**Table 2-19: 6-Inch Single Wythe Walls**

Masonry Spanning Vertically										
Unit Configuration	Grout Spacing (in.)	Mortar Bedding	Net Cross-Sectional Properties <sup>A</sup>				Average Cross-Sectional Properties <sup>B</sup>			
			A <sub>n</sub> (in <sup>2</sup> /ft)	I <sub>n</sub> (in <sup>4</sup> /ft)	S <sub>n</sub> (in <sup>3</sup> /ft)	r <sub>n</sub> (in/ft)	A <sub>avg</sub> (in <sup>2</sup> /ft)	I <sub>avg</sub> (in <sup>4</sup> /ft)	S <sub>avg</sub> (in <sup>3</sup> /ft)	r <sub>avg</sub> (in/ft)
Hollow	No Grout	Face Shell	24.0	130.3	46.3	2.33	32.2	139.3	49.5	2.08
Hollow	No Grout	Full	32.2	139.3	49.5	2.08	32.2	139.3	49.5	2.08
100% Solid	No Grout	Full	67.5	178.0	63.3	1.62	67.5	178.0	63.3	1.62
Hollow	8 in. o.c.	Full	67.5	178.0	63.3	1.62	67.5	178.0	63.3	1.62
Hollow	16 in. o.c.	Face Shell	46.6	155.1	55.1	1.82	49.3	158.1	56.2	1.79
Hollow	24 in. o.c.	Face Shell	39.1	146.8	52.2	1.94	43.6	151.8	54.0	1.87
Hollow	32 in. o.c.	Face Shell	35.3	142.7	50.7	2.01	40.7	148.7	52.9	1.91
Hollow	40 in. o.c.	Face Shell	33.0	140.2	49.9	2.06	39.0	146.8	52.2	1.94
Hollow	48 in. o.c.	Face Shell	31.5	138.6	49.3	2.10	37.9	145.5	51.7	1.96
Hollow	56 in. o.c.	Face Shell	30.5	137.4	48.9	2.12	37.1	144.6	51.4	1.98
Hollow	64 in. o.c.	Face Shell	29.6	136.5	48.5	2.15	36.4	144.0	51.2	1.99
Hollow	72 in. o.c.	Face Shell	29.0	135.8	48.3	2.16	36.0	143.5	51.0	2.00
Hollow	80 in. o.c.	Face Shell	28.5	135.3	48.1	2.18	35.6	143.0	50.9	2.00
Hollow	88 in. o.c.	Face Shell	28.1	134.8	47.9	2.19	35.3	142.7	50.7	2.01
Hollow	96 in. o.c.	Face Shell	27.8	134.5	47.8	2.20	35.0	142.4	50.6	2.02
Hollow	104 in. o.c.	Face Shell	27.5	134.2	47.7	2.21	34.8	142.2	50.5	2.02
Hollow	112 in. o.c.	Face Shell	27.2	133.9	47.6	2.22	34.6	142.0	50.5	2.03
Hollow	120 in. o.c.	Face Shell	27.0	133.6	47.5	2.22	34.4	141.8	50.4	2.03
Masonry Spanning Horizontally										
Unit Configuration	Grout Spacing (in.)	Mortar Bedding	Net Cross-Sectional Properties <sup>A</sup>				Average Cross-Sectional Properties <sup>B</sup>			
			A <sub>n</sub> (in <sup>2</sup> /ft)	I <sub>n</sub> (in <sup>4</sup> /ft)	S <sub>n</sub> (in <sup>3</sup> /ft)	r <sub>n</sub> (in/ft)	A <sub>avg</sub> (in <sup>2</sup> /ft)	I <sub>avg</sub> (in <sup>4</sup> /ft)	S <sub>avg</sub> (in <sup>3</sup> /ft)	r <sub>avg</sub> (in/ft)
Hollow	No Grout	Face Shell	24.0	130.3	46.3	2.33	31.4	130.3	46.3	2.04
Hollow	No Grout	Full	24.0	130.3	46.3	2.33	32.2	130.3	46.3	2.01
100% Solid	No Grout	Full	67.5	178.0	63.3	1.62	67.5	178.0	63.3	1.62
Hollow	8 in. o.c.	Full	67.5	178.0	63.3	1.62	67.5	178.0	63.3	1.62
Hollow	16 in. o.c.	Face Shell	24.0	130.3	46.3	2.33	45.8	154.2	54.8	1.84
Hollow	24 in. o.c.	Face Shell	24.0	130.3	46.3	2.33	38.5	146.2	52.0	1.95
Hollow	32 in. o.c.	Face Shell	24.0	130.3	46.3	2.33	34.9	142.3	50.6	2.02
Hollow	40 in. o.c.	Face Shell	24.0	130.3	46.3	2.33	32.7	139.9	49.7	2.07
Hollow	48 in. o.c.	Face Shell	24.0	130.3	46.3	2.33	31.3	138.3	49.2	2.10
Hollow	56 in. o.c.	Face Shell	24.0	130.3	46.3	2.33	30.2	137.1	48.8	2.13
Hollow	64 in. o.c.	Face Shell	24.0	130.3	46.3	2.33	29.4	136.3	48.5	2.15
Hollow	72 in. o.c.	Face Shell	24.0	130.3	46.3	2.33	28.8	135.6	48.2	2.17
Hollow	80 in. o.c.	Face Shell	24.0	130.3	46.3	2.33	28.4	135.1	48.0	2.18
Hollow	88 in. o.c.	Face Shell	24.0	130.3	46.3	2.33	28.0	134.7	47.9	2.19
Hollow	96 in. o.c.	Face Shell	24.0	130.3	46.3	2.33	27.6	134.3	47.8	2.20
Hollow	104 in. o.c.	Face Shell	24.0	130.3	46.3	2.33	27.3	134.0	47.6	2.21
Hollow	112 in. o.c.	Face Shell	24.0	130.3	46.3	2.33	27.1	133.7	47.6	2.22
Hollow	120 in. o.c.	Face Shell	24.0	130.3	46.3	2.33	26.9	133.5	47.5	2.23

**Wall Weights**

Unit Configuration	Grout Spacing (in.)	Mortar Bedding	Wall Weight (lb/ft <sup>2</sup> ) for Concrete Densities (lb/ft <sup>3</sup> ) of:				
			95	105	115	125	135
Hollow	No Grout	Face Shell	22	24	26	28	30
Hollow	No Grout	Full	22	24	26	28	31
100% Solid	No Grout	Full	46	50	55	59	63
Hollow	8 in. o.c.	Full	56	58	60	62	64
Hollow	16 in. o.c.	Face Shell	39	41	43	45	47
Hollow	24 in. o.c.	Face Shell	33	35	37	39	41
Hollow	32 in. o.c.	Face Shell	30	32	34	37	39
Hollow	40 in. o.c.	Face Shell	29	31	33	35	37
Hollow	48 in. o.c.	Face Shell	27	30	32	34	36
Hollow	56 in. o.c.	Face Shell	27	29	31	33	35
Hollow	64 in. o.c.	Face Shell	26	28	30	32	34
Hollow	72 in. o.c.	Face Shell	26	28	30	32	34
Hollow	80 in. o.c.	Face Shell	25	27	29	31	34
Hollow	88 in. o.c.	Face Shell	25	27	29	31	33
Hollow	96 in. o.c.	Face Shell	25	27	29	31	33
Hollow	104 in. o.c.	Face Shell	24	27	29	31	33
Hollow	112 in. o.c.	Face Shell	24	26	28	30	33
Hollow	120 in. o.c.	Face Shell	24	26	28	30	32

<sup>A</sup>Net cross-sectional properties are to be used for determining stress and strain from load application.

<sup>B</sup>Average cross-sectional properties are used for determining stiffness and deflection of an element.

**Table 2-20: 8-Inch Single Wythe Walls**

<b>Masonry Spanning Vertically</b>											
Unit Configuration	Grout Spacing (in.)	Mortar Bedding	Net Cross-Sectional Properties <sup>A</sup>				Average Cross-Sectional Properties <sup>B</sup>				
			A <sub>n</sub> (in <sup>2</sup> /ft)	I <sub>n</sub> (in <sup>4</sup> /ft)	S <sub>n</sub> (in <sup>3</sup> /ft)	r <sub>n</sub> (in/ft)	A <sub>avg</sub> (in <sup>2</sup> /ft)	I <sub>avg</sub> (in <sup>4</sup> /ft)	S <sub>avg</sub> (in <sup>3</sup> /ft)	r <sub>avg</sub> (in/ft)	
Hollow	No Grout	Face Shell	30.0	308.7	81.0	3.21	41.5	334.0	87.6	2.84	
Hollow	No Grout	Full	41.5	334.0	87.6	2.84	41.5	334.0	87.6	2.84	
100% Solid	No Grout	Full	91.5	443.3	116.3	2.20	91.5	443.3	116.3	2.20	
Hollow	8 in. o.c.	Full	91.5	443.3	116.3	2.20	91.5	443.3	116.3	2.20	
Hollow	16 in. o.c.	Face Shell	62.0	378.6	99.3	2.47	65.8	387.1	101.5	2.43	
Hollow	24 in. o.c.	Face Shell	51.3	355.3	93.2	2.63	57.7	369.4	96.9	2.53	
Hollow	32 in. o.c.	Face Shell	46.0	343.7	90.1	2.73	53.7	360.5	94.6	2.59	
Hollow	40 in. o.c.	Face Shell	42.8	336.7	88.3	2.81	51.2	355.2	93.2	2.63	
Hollow	48 in. o.c.	Face Shell	40.7	332.0	87.1	2.86	49.6	351.7	92.2	2.66	
Hollow	56 in. o.c.	Face Shell	39.1	328.7	86.2	2.90	48.5	349.1	91.6	2.68	
Hollow	64 in. o.c.	Face Shell	38.0	326.2	85.6	2.93	47.6	347.2	91.1	2.70	
Hollow	72 in. o.c.	Face Shell	37.1	324.3	85.0	2.96	46.9	345.8	90.7	2.71	
Hollow	80 in. o.c.	Face Shell	36.4	322.7	84.6	2.98	46.4	344.6	90.4	2.73	
Hollow	88 in. o.c.	Face Shell	35.8	321.4	84.3	3.00	45.9	343.6	90.1	2.73	
Hollow	96 in. o.c.	Face Shell	35.3	320.4	84.0	3.01	45.6	342.8	89.9	2.74	
Hollow	104 in. o.c.	Face Shell	34.9	319.5	83.8	3.02	45.3	342.1	89.7	2.75	
Hollow	112 in. o.c.	Face Shell	34.6	318.7	83.6	3.04	45.0	341.5	89.6	2.76	
Hollow	120 in. o.c.	Face Shell	34.3	318.0	83.4	3.05	44.8	341.0	89.5	2.76	
<b>Masonry Spanning Horizontally</b>											
Unit Configuration	Grout Spacing (in.)	Mortar Bedding	Net Cross-Sectional Properties <sup>A</sup>				Average Cross-Sectional Properties <sup>B</sup>				
			A <sub>n</sub> (in <sup>2</sup> /ft)	I <sub>n</sub> (in <sup>4</sup> /ft)	S <sub>n</sub> (in <sup>3</sup> /ft)	r <sub>n</sub> (in/ft)	A <sub>avg</sub> (in <sup>2</sup> /ft)	I <sub>avg</sub> (in <sup>4</sup> /ft)	S <sub>avg</sub> (in <sup>3</sup> /ft)	r <sub>avg</sub> (in/ft)	
Hollow	No Grout	Face Shell	30.0	308.7	81.0	3.21	40.5	308.7	81.0	2.76	
Hollow	No Grout	Full	30.0	308.7	81.0	3.21	41.5	308.7	81.0	2.73	
100% Solid	No Grout	Full	91.5	443.3	116.3	2.20	91.5	443.3	116.3	2.20	
Hollow	8 in. o.c.	Full	91.5	443.3	116.3	2.20	91.5	443.3	116.3	2.20	
Hollow	16 in. o.c.	Face Shell	30.0	308.7	81.0	3.21	60.8	376.0	98.6	2.49	
Hollow	24 in. o.c.	Face Shell	30.0	308.7	81.0	3.21	50.5	353.6	92.7	2.65	
Hollow	32 in. o.c.	Face Shell	30.0	308.7	81.0	3.21	45.4	342.4	89.8	2.75	
Hollow	40 in. o.c.	Face Shell	30.0	308.7	81.0	3.21	42.3	335.6	88.0	2.82	
Hollow	48 in. o.c.	Face Shell	30.0	308.7	81.0	3.21	40.3	331.1	86.9	2.87	
Hollow	56 in. o.c.	Face Shell	30.0	308.7	81.0	3.21	38.8	327.9	86.0	2.91	
Hollow	64 in. o.c.	Face Shell	30.0	308.7	81.0	3.21	37.7	325.5	85.4	2.94	
Hollow	72 in. o.c.	Face Shell	30.0	308.7	81.0	3.21	36.8	323.7	84.9	2.96	
Hollow	80 in. o.c.	Face Shell	30.0	308.7	81.0	3.21	36.2	322.2	84.5	2.99	
Hollow	88 in. o.c.	Face Shell	30.0	308.7	81.0	3.21	35.6	320.9	84.2	3.00	
Hollow	96 in. o.c.	Face Shell	30.0	308.7	81.0	3.21	35.1	319.9	83.9	3.02	
Hollow	104 in. o.c.	Face Shell	30.0	308.7	81.0	3.21	34.7	319.1	83.7	3.03	
Hollow	112 in. o.c.	Face Shell	30.0	308.7	81.0	3.21	34.4	318.3	83.5	3.04	
Hollow	120 in. o.c.	Face Shell	30.0	308.7	81.0	3.21	34.1	317.7	83.3	3.05	

**Wall Weights**

Unit Configuration	Grout Spacing (in.)	Mortar Bedding	Wall Weight (lb/ft <sup>2</sup> ) for Concrete Densities (lb/ft <sup>3</sup> ) of:				
			95	105	115	125	135
Hollow	No Grout	Face Shell	28	31	33	36	39
Hollow	No Grout	Full	28	31	34	37	39
100% Solid	No Grout	Full	62	68	74	80	86
Hollow	8 in. o.c.	Full	76	78	81	84	86
Hollow	16 in. o.c.	Face Shell	52	55	57	60	63
Hollow	24 in. o.c.	Face Shell	44	47	49	52	55
Hollow	32 in. o.c.	Face Shell	40	43	45	48	51
Hollow	40 in. o.c.	Face Shell	38	40	43	46	48
Hollow	48 in. o.c.	Face Shell	36	39	41	44	47
Hollow	56 in. o.c.	Face Shell	35	38	40	43	46
Hollow	64 in. o.c.	Face Shell	34	37	39	42	45
Hollow	72 in. o.c.	Face Shell	33	36	39	41	44
Hollow	80 in. o.c.	Face Shell	33	35	38	41	44
Hollow	88 in. o.c.	Face Shell	32	35	38	40	43
Hollow	96 in. o.c.	Face Shell	32	35	37	40	43
Hollow	104 in. o.c.	Face Shell	32	34	37	40	42
Hollow	112 in. o.c.	Face Shell	31	34	37	39	42
Hollow	120 in. o.c.	Face Shell	31	34	37	39	42

<sup>A</sup>Net cross-sectional properties are to be used for determining stress and strain from load application.

<sup>B</sup>Average cross-sectional properties are used for determining stiffness and deflection of an element.

**Table 2-21: 10-Inch Single Wythe Walls**

<b>Masonry Spanning Vertically</b>										
Unit Configuration	Grout Spacing (in.)	Mortar Bedding	Net Cross-Sectional Properties <sup>A</sup>				Average Cross-Sectional Properties <sup>B</sup>			
			A <sub>n</sub> (in <sup>2</sup> /ft)	I <sub>n</sub> (in <sup>4</sup> /ft)	S <sub>n</sub> (in <sup>3</sup> /ft)	r <sub>n</sub> (in/ft)	A <sub>avg</sub> (in <sup>2</sup> /ft)	I <sub>avg</sub> (in <sup>4</sup> /ft)	S <sub>avg</sub> (in <sup>3</sup> /ft)	r <sub>avg</sub> (in/ft)
Hollow	No Grout	Face Shell	33.0	566.7	117.8	4.14	50.4	635.3	132.0	3.55
Hollow	No Grout	Full	50.4	635.3	132.0	3.55	50.4	635.3	132.0	3.55
100% Solid	No Grout	Full	115.5	891.7	185.3	2.78	115.5	891.7	185.3	2.78
Hollow	8 in. o.c.	Full	115.5	891.7	185.3	2.78	115.5	891.7	185.3	2.78
Hollow	16 in. o.c.	Face Shell	76.2	736.8	153.1	3.11	82.0	759.7	157.9	3.04
Hollow	24 in. o.c.	Face Shell	61.8	680.1	141.3	3.32	71.5	718.2	149.2	3.17
Hollow	32 in. o.c.	Face Shell	54.6	651.8	135.4	3.46	66.2	697.5	144.9	3.25
Hollow	40 in. o.c.	Face Shell	50.3	634.8	131.9	3.55	63.0	685.0	142.3	3.30
Hollow	48 in. o.c.	Face Shell	47.4	623.4	129.5	3.63	60.9	676.7	140.6	3.33
Hollow	56 in. o.c.	Face Shell	45.3	615.3	127.9	3.68	59.4	670.8	139.4	3.36
Hollow	64 in. o.c.	Face Shell	43.8	609.2	126.6	3.73	58.3	666.4	138.5	3.38
Hollow	72 in. o.c.	Face Shell	42.6	604.5	125.6	3.77	57.4	662.9	137.7	3.40
Hollow	80 in. o.c.	Face Shell	41.6	600.7	124.8	3.80	56.7	660.1	137.2	3.41
Hollow	88 in. o.c.	Face Shell	40.9	597.6	124.2	3.82	56.1	657.9	136.7	3.42
Hollow	96 in. o.c.	Face Shell	40.2	595.1	123.6	3.85	55.7	656.0	136.3	3.43
Hollow	104 in. o.c.	Face Shell	39.6	592.9	123.2	3.87	55.3	654.4	136.0	3.44
Hollow	112 in. o.c.	Face Shell	39.2	591.0	122.8	3.88	54.9	653.0	135.7	3.45
Hollow	120 in. o.c.	Face Shell	38.8	589.4	122.5	3.90	54.6	651.8	135.4	3.45
<b>Masonry Spanning Horizontally</b>										
Unit Configuration	Grout Spacing (in.)	Mortar Bedding	Net Cross-Sectional Properties <sup>A</sup>				Average Cross-Sectional Properties <sup>B</sup>			
			A <sub>n</sub> (in <sup>2</sup> /ft)	I <sub>n</sub> (in <sup>4</sup> /ft)	S <sub>n</sub> (in <sup>3</sup> /ft)	r <sub>n</sub> (in/ft)	A <sub>avg</sub> (in <sup>2</sup> /ft)	I <sub>avg</sub> (in <sup>4</sup> /ft)	S <sub>avg</sub> (in <sup>3</sup> /ft)	r <sub>avg</sub> (in/ft)
Hollow	No Grout	Face Shell	33.0	566.7	117.8	4.14	48.8	566.7	117.8	3.41
Hollow	No Grout	Full	33.0	566.7	117.8	4.14	50.4	566.7	117.8	3.35
100% Solid	No Grout	Full	115.5	891.7	185.3	2.78	115.5	891.7	185.3	2.78
Hollow	8 in. o.c.	Full	115.5	891.7	185.3	2.78	115.5	891.7	185.3	2.78
Hollow	16 in. o.c.	Face Shell	33.0	566.7	117.8	4.14	74.3	729.2	151.5	3.13
Hollow	24 in. o.c.	Face Shell	33.0	566.7	117.8	4.14	60.5	675.0	140.3	3.34
Hollow	32 in. o.c.	Face Shell	33.0	566.7	117.8	4.14	53.6	648.0	134.6	3.48
Hollow	40 in. o.c.	Face Shell	33.0	566.7	117.8	4.14	49.5	631.7	131.3	3.57
Hollow	48 in. o.c.	Face Shell	33.0	566.7	117.8	4.14	46.8	620.9	129.0	3.64
Hollow	56 in. o.c.	Face Shell	33.0	566.7	117.8	4.14	44.8	613.1	127.4	3.70
Hollow	64 in. o.c.	Face Shell	33.0	566.7	117.8	4.14	43.3	607.3	126.2	3.74
Hollow	72 in. o.c.	Face Shell	33.0	566.7	117.8	4.14	42.2	602.8	125.3	3.78
Hollow	80 in. o.c.	Face Shell	33.0	566.7	117.8	4.14	41.3	599.2	124.5	3.81
Hollow	88 in. o.c.	Face Shell	33.0	566.7	117.8	4.14	40.5	596.3	123.9	3.84
Hollow	96 in. o.c.	Face Shell	33.0	566.7	117.8	4.14	39.9	593.8	123.4	3.86
Hollow	104 in. o.c.	Face Shell	33.0	566.7	117.8	4.14	39.3	591.7	123.0	3.88
Hollow	112 in. o.c.	Face Shell	33.0	566.7	117.8	4.14	38.9	589.9	122.6	3.89
Hollow	120 in. o.c.	Face Shell	33.0	566.7	117.8	4.14	38.5	588.4	122.3	3.91

**Wall Weights**

Unit Configuration	Grout Spacing (in.)	Mortar Bedding	Wall Weight (lb/ft <sup>2</sup> ) for Concrete Densities (lb/ft <sup>3</sup> ) of:				
			95	105	115	125	135
Hollow	No Grout	Face Shell	34	37	40	44	47
Hollow	No Grout	Full	34	38	41	44	48
100% Solid	No Grout	Full	78	86	93	101	108
Hollow	8 in. o.c.	Full	96	99	102	106	109
Hollow	16 in. o.c.	Face Shell	65	68	71	75	78
Hollow	24 in. o.c.	Face Shell	54	58	61	64	68
Hollow	32 in. o.c.	Face Shell	49	53	56	59	62
Hollow	40 in. o.c.	Face Shell	46	49	53	56	59
Hollow	48 in. o.c.	Face Shell	44	47	51	54	57
Hollow	56 in. o.c.	Face Shell	43	46	49	52	56
Hollow	64 in. o.c.	Face Shell	41	45	48	51	55
Hollow	72 in. o.c.	Face Shell	41	44	47	50	54
Hollow	80 in. o.c.	Face Shell	40	43	46	50	53
Hollow	88 in. o.c.	Face Shell	39	43	46	49	52
Hollow	96 in. o.c.	Face Shell	39	42	45	49	52
Hollow	104 in. o.c.	Face Shell	38	42	45	48	52
Hollow	112 in. o.c.	Face Shell	38	41	45	48	51
Hollow	120 in. o.c.	Face Shell	38	41	44	48	51

<sup>A</sup>Net cross-sectional properties are to be used for determining stress and strain from load application.

<sup>B</sup>Average cross-sectional properties are used for determining stiffness and deflection of an element.



**Table 2-22: 12-Inch Single Wythe Walls**

Masonry Spanning Vertically										
Unit Configuration	Grout Spacing (in.)	Mortar Bedding	Net Cross-Sectional Properties <sup>A</sup>				Average Cross-Sectional Properties <sup>B</sup>			
			A <sub>n</sub> (in <sup>2</sup> /ft)	I <sub>n</sub> (in <sup>4</sup> /ft)	S <sub>n</sub> (in <sup>3</sup> /ft)	r <sub>n</sub> (in/ft)	A <sub>avg</sub> (in <sup>2</sup> /ft)	I <sub>avg</sub> (in <sup>4</sup> /ft)	S <sub>avg</sub> (in <sup>3</sup> /ft)	r <sub>avg</sub> (in/ft)
Hollow	No Grout	Face Shell	36.0	929.4	159.9	5.08	57.8	1064.7	183.2	4.29
Hollow	No Grout	Full	57.8	1064.7	183.2	4.29	57.8	1064.7	183.2	4.29
100% Solid	No Grout	Full	139.5	1571.0	270.3	3.36	139.5	1571.0	270.3	3.36
Hollow	8 in. o.c.	Full	139.5	1571.0	270.3	3.36	139.5	1571.0	270.3	3.36
Hollow	16 in. o.c.	Face Shell	90.2	1265.2	217.7	3.75	97.5	1310.4	225.4	3.67
Hollow	24 in. o.c.	Face Shell	72.1	1153.3	198.4	4.00	84.2	1228.5	211.4	3.82
Hollow	32 in. o.c.	Face Shell	63.1	1097.3	188.8	4.17	77.6	1187.5	204.3	3.91
Hollow	40 in. o.c.	Face Shell	57.7	1063.7	183.0	4.29	73.7	1163.0	200.1	3.97
Hollow	48 in. o.c.	Face Shell	54.1	1041.3	179.2	4.39	71.0	1146.6	197.3	4.02
Hollow	56 in. o.c.	Face Shell	51.5	1025.3	176.4	4.46	69.2	1134.9	195.3	4.05
Hollow	64 in. o.c.	Face Shell	49.5	1013.4	174.3	4.52	67.7	1126.1	193.7	4.08
Hollow	72 in. o.c.	Face Shell	48.0	1004.0	172.7	4.57	66.6	1119.3	192.6	4.10
Hollow	80 in. o.c.	Face Shell	46.8	996.6	171.5	4.61	65.8	1113.9	191.6	4.12
Hollow	88 in. o.c.	Face Shell	45.9	990.5	170.4	4.65	65.0	1109.4	190.9	4.13
Hollow	96 in. o.c.	Face Shell	45.0	985.4	169.5	4.68	64.4	1105.7	190.2	4.14
Hollow	104 in. o.c.	Face Shell	44.3	981.1	168.8	4.70	63.9	1102.5	189.7	4.15
Hollow	112 in. o.c.	Face Shell	43.7	977.4	168.1	4.73	63.5	1099.8	189.2	4.16
Hollow	120 in. o.c.	Face Shell	43.2	974.2	167.6	4.75	63.1	1097.5	188.8	4.17
Masonry Spanning Horizontally										
Unit Configuration	Grout Spacing (in.)	Mortar Bedding	Net Cross-Sectional Properties <sup>A</sup>				Average Cross-Sectional Properties <sup>B</sup>			
			A <sub>n</sub> (in <sup>2</sup> /ft)	I <sub>n</sub> (in <sup>4</sup> /ft)	S <sub>n</sub> (in <sup>3</sup> /ft)	r <sub>n</sub> (in/ft)	A <sub>avg</sub> (in <sup>2</sup> /ft)	I <sub>avg</sub> (in <sup>4</sup> /ft)	S <sub>avg</sub> (in <sup>3</sup> /ft)	r <sub>avg</sub> (in/ft)
Hollow	No Grout	Face Shell	36.0	929.4	159.9	5.08	55.8	929.4	159.9	4.08
Hollow	No Grout	Full	36.0	929.4	159.9	5.08	57.8	929.4	159.9	4.01
100% Solid	No Grout	Full	139.5	1571.0	270.3	3.36	139.5	1571.0	270.3	3.36
Hollow	8 in. o.c.	Full	139.5	1571.0	270.3	3.36	139.5	1571.0	270.3	3.36
Hollow	16 in. o.c.	Face Shell	36.0	929.4	159.9	5.08	87.8	1250.2	215.1	3.77
Hollow	24 in. o.c.	Face Shell	36.0	929.4	159.9	5.08	70.5	1143.3	196.7	4.03
Hollow	32 in. o.c.	Face Shell	36.0	929.4	159.9	5.08	61.9	1089.8	187.5	4.20
Hollow	40 in. o.c.	Face Shell	36.0	929.4	159.9	5.08	56.7	1057.7	182.0	4.32
Hollow	48 in. o.c.	Face Shell	36.0	929.4	159.9	5.08	53.3	1036.3	178.3	4.41
Hollow	56 in. o.c.	Face Shell	36.0	929.4	159.9	5.08	50.8	1021.1	175.7	4.48
Hollow	64 in. o.c.	Face Shell	36.0	929.4	159.9	5.08	48.9	1009.6	173.7	4.54
Hollow	72 in. o.c.	Face Shell	36.0	929.4	159.9	5.08	47.5	1000.7	172.2	4.59
Hollow	80 in. o.c.	Face Shell	36.0	929.4	159.9	5.08	46.4	993.6	170.9	4.63
Hollow	88 in. o.c.	Face Shell	36.0	929.4	159.9	5.08	45.4	987.7	169.9	4.66
Hollow	96 in. o.c.	Face Shell	36.0	929.4	159.9	5.08	44.6	982.9	169.1	4.69
Hollow	104 in. o.c.	Face Shell	36.0	929.4	159.9	5.08	44.0	978.7	168.4	4.72
Hollow	112 in. o.c.	Face Shell	36.0	929.4	159.9	5.08	43.4	975.2	167.8	4.74
Hollow	120 in. o.c.	Face Shell	36.0	929.4	159.9	5.08	42.9	972.2	167.3	4.76

**Wall Weights**

Unit Configuration	Grout Spacing (in.)	Mortar Bedding	Wall Weight (lb/ft <sup>2</sup> ) for Concrete Densities (lb/ft <sup>3</sup> ) of:				
			95	105	115	125	135
Hollow	No Grout	Face Shell	38	42	46	50	54
Hollow	No Grout	Full	39	43	47	51	54
100% Solid	No Grout	Full	95	104	113	122	131
Hollow	8 in. o.c.	Full	116	120	124	128	132
Hollow	16 in. o.c.	Face Shell	78	81	85	89	93
Hollow	24 in. o.c.	Face Shell	65	68	72	76	80
Hollow	32 in. o.c.	Face Shell	58	62	66	69	73
Hollow	40 in. o.c.	Face Shell	54	58	62	65	69
Hollow	48 in. o.c.	Face Shell	52	55	59	63	67
Hollow	56 in. o.c.	Face Shell	50	53	57	61	65
Hollow	64 in. o.c.	Face Shell	48	52	56	60	63
Hollow	72 in. o.c.	Face Shell	47	51	55	59	62
Hollow	80 in. o.c.	Face Shell	46	50	54	58	61
Hollow	88 in. o.c.	Face Shell	46	49	53	57	61
Hollow	96 in. o.c.	Face Shell	45	49	53	56	60
Hollow	104 in. o.c.	Face Shell	45	48	52	56	60
Hollow	112 in. o.c.	Face Shell	44	48	52	55	59
Hollow	120 in. o.c.	Face Shell	44	47	51	55	59

<sup>A</sup>Net cross-sectional properties are to be used for determining stress and strain from load application.

<sup>B</sup>Average cross-sectional properties are used for determining stiffness and deflection of an element.

## 2.6 Allowable Stress Design

### 2.6.1 Design Assumptions

This section of the manual focuses on the allowable stress design procedures as reported by the Masonry Standards Joint Committee (MSJC) in the national masonry standard ACI 530-99/ASCE 5-99/TMS 402-99. The allowable stress design method is based on the following general assumptions:

- stress is linearly proportional to strain for stresses within the allowable stress range;
- plane sections before bending remain plane after bending;
- strain is linearly proportional to the distance from the neutral axis;
- the masonry (units, mortar, grout, and reinforcement) is bonded together into a composite assemblage; and
- the materials exhibit linear elastic behavior for stresses within the allowable range.

In accordance with the provisions of the Code, the allowable stresses can be increased by one-third when load combinations include wind or seismic loads. Therefore, the design tables and graphs provided in this section distinguish between load combinations that include wind or seismic and load combinations that do not include such loads. Additional assumptions are detailed in the following sections.

#### 2.6.1.1 Material Properties

Material properties used for design are based on the values reported by the MSJC (Ref. 8). The modulus of elasticity of the reinforcing steel is taken as  $E_s = 29,000,000$  psi (Code Section 1.8.2.1). Elastic modulus of concrete masonry varies linearly with the specified compressive strength of the masonry,  $fN_m$ , in accordance with Code Section 1.8.2.2.1  $E_m = 900 fN_m$ .

### 2.6.2 Reinforced Concrete Masonry Walls

Requirements for design of reinforced concrete masonry are contained in the Code (Ref. 8). The referenced section provides design requirements for axial compression and tension, flexure, and shear. For reinforced concrete masonry walls, the compressive resistance of steel reinforcement and the tensile resistance of masonry are neglected.

Tables 2-23 through 2-39 provide bending moment and shear capacities for reinforced masonry walls constructed of 8, 10, and 12-inch concrete masonry units with varying reinforcing bar sizes and spacings. Similarly, Charts 2-1 through 2-21 provide interaction diagrams for bending moment and axial load using 8, 10, and 12-inch concrete masonry units with varying reinforcing bar sizes and spacings.

### 2.6.3 Unreinforced Concrete Masonry Walls

Criteria for the design of unreinforced concrete masonry are contained in the Code (Ref. 8). For unreinforced design, the masonry is design to resist all tensile and compressive loads. While the masonry may in fact contain reinforcement, it is neglected in the design.

Tables 2-40 through 2-43 provide bending moment and shear capacities for unreinforced masonry walls constructed of 8, 10, and 12-inch concrete masonry units. Similarly, Charts 2-22 through 2-27 provide interaction diagrams for bending moment and axial load using 8, 10, and 12-inch concrete masonry units in unreinforced construction.

**Table 2-23: Out-of-Plane Bending Moment and Shear Capacity for Reinforced Masonry**

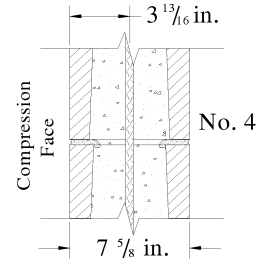
Nominal Thickness = 8 in.

Bar Size = No. 4

Reinforcement = Grade 60

Effective Depth = 3.813 in.

Note: When steel spacing exceeds 6 times the wall thickness or 72 inches, the portion of masonry spanning between bars shall be designed as unreinforced.



$f_m$ (psi) =	Load Combinations Not Including Wind or Seismic				Load Combinations Including Wind or Seismic			
	1,500		2,500		1,500		2,500	
	$M_R$ (ft-lb/ft)	$V_R$ (lb/ft)	$M_R$ (ft-lb/ft)	$V_R$ (lb/ft)	$M_R$ (ft-lb/ft)	$V_R$ (lb/ft)	$M_R$ (ft-lb/ft)	$V_R$ (lb/ft)
8	1,281	1,771	1,803	2,287	1,708	2,361	2,404	3,049
16	1,014	1,771	1,047	2,287	1,352	2,361	1,396	3,049
24	695	1,771	708	2,287	926	2,361	944	3,049
32	527	1,771	536	2,287	702	2,361	714	3,049
40	425	1,771	431	2,287	566	2,361	574	3,049
48	356	1,771	361	2,287	474	2,361	481	3,049
56	305	1,518	309	1,960	406	2,024	412	2,613
64	267	1,328	270	1,715	356	1,770	360	2,286
72	237	1,180	240	1,524	316	1,573	320	2,032
80	213	1,062	216	1,372	284	1,416	288	1,829
88	194	966	196	1,247	258	1,288	261	1,662
96	178	885	180	1,143	237	1,180	240	1,524
104	164	817	166	1,055	218	1,089	221	1,406
112	152	759	154	980	202	1,012	205	1,306
120	142	708	144	914	189	944	192	1,218

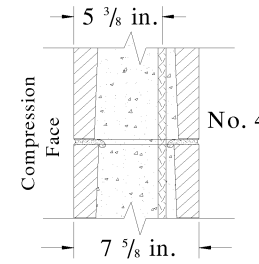
Nominal Thickness = 8 in.

Bar Size = No. 4

Reinforcement = Grade 60

Effective Depth = 5.375 in.

Note: When steel spacing exceeds 6 times the wall thickness or 72 inches, the portion of masonry spanning between bars shall be designed as unreinforced.

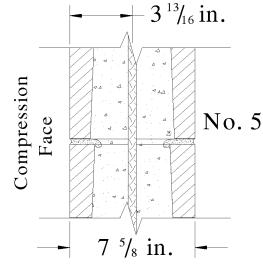


$f_m$ (psi) =	Load Combinations Not Including Wind or Seismic				Load Combinations Including Wind or Seismic			
	1,500		2,500		1,500		2,500	
	$M_R$ (ft-lb/ft)	$V_R$ (lb/ft)	$M_R$ (ft-lb/ft)	$V_R$ (lb/ft)	$M_R$ (ft-lb/ft)	$V_R$ (lb/ft)	$M_R$ (ft-lb/ft)	$V_R$ (lb/ft)
8	2,277	2,498	2,911	3,225	3,036	3,330	3,881	4,300
16	1,467	2,498	1,496	3,225	1,956	3,330	1,994	4,300
24	993	2,498	1,010	3,225	1,324	3,330	1,346	4,300
32	752	2,498	763	3,225	1,002	3,330	1,017	4,300
40	606	2,498	614	3,225	808	3,330	818	4,300
48	507	2,498	513	3,225	676	3,330	684	4,300
56	434	2,141	439	2,764	578	2,854	585	3,685
64	380	1,873	384	2,418	506	2,497	512	3,224
72	338	1,665	342	2,150	450	2,220	456	2,866
80	304	1,498	307	1,935	405	1,997	409	2,580
88	276	1,362	279	1,759	368	1,816	372	2,345
96	253	1,249	256	1,612	337	1,665	341	2,149
104	234	1,152	236	1,488	312	1,536	314	1,984
112	217	1,070	219	1,382	289	1,426	292	1,842
120	202	999	205	1,290	269	1,332	273	1,720

**Table 2-24: Out-of-Plane Bending Moment and Shear Capacity for Reinforced Masonry**

Nominal Thickness = 8 in.  
 Bar Size = No. 5  
 Reinforcement = Grade 60  
 Effective Depth = 3.813 in.

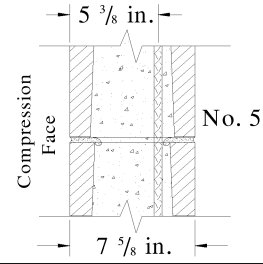
Note: When steel spacing exceeds 6 times the wall thickness or 72 inches, the portion of masonry spanning between bars shall be designed as unreinforced.



$f_m$ (psi) =	Load Combinations Not Including Wind or Seismic				Load Combinations Including Wind or Seismic			
	1,500		2,500		1,500		2,500	
	$M_R$ (ft-lb/ft)	$V_R$ (lb/ft)	$M_R$ (ft-lb/ft)	$V_R$ (lb/ft)	$M_R$ (ft-lb/ft)	$V_R$ (lb/ft)	$M_R$ (ft-lb/ft)	$V_R$ (lb/ft)
8	1,459	1,771	2,087	2,287	1,945	2,361	2,782	3,049
16	1,180	1,771	1,594	2,287	1,573	2,361	2,125	3,049
24	1,026	1,771	1,081	2,287	1,368	2,361	1,441	3,049
32	803	1,771	819	2,287	1,070	2,361	1,092	3,049
40	648	1,771	660	2,287	864	2,361	880	3,049
48	544	1,771	553	2,287	725	2,361	737	3,049
56	466	1,518	474	1,960	621	2,024	632	2,613
64	408	1,328	414	1,715	544	1,770	552	2,286
72	362	1,180	368	1,524	482	1,573	490	2,032
80	326	1,062	331	1,372	434	1,416	441	1,829
88	296	966	301	1,247	394	1,288	401	1,662
96	272	885	276	1,143	362	1,180	368	1,524
104	251	817	255	1,055	334	1,089	340	1,406
112	233	759	237	980	310	1,012	316	1,306
120	217	708	221	914	289	944	294	1,218

Nominal Thickness = 8 in.  
 Bar Size = No. 5  
 Reinforcement = Grade 60  
 Effective Depth = 5.375 in.

Note: When steel spacing exceeds 6 times the wall thickness or 72 inches, the portion of masonry spanning between bars shall be designed as unreinforced.

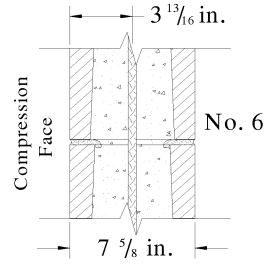


$f_m$ (psi) =	Load Combinations Not Including Wind or Seismic				Load Combinations Including Wind or Seismic			
	1,500		2,500		1,500		2,500	
	$M_R$ (ft-lb/ft)	$V_R$ (lb/ft)	$M_R$ (ft-lb/ft)	$V_R$ (lb/ft)	$M_R$ (ft-lb/ft)	$V_R$ (lb/ft)	$M_R$ (ft-lb/ft)	$V_R$ (lb/ft)
8	2,623	2,498	3,703	3,225	3,497	3,330	4,937	4,300
16	2,085	2,498	2,281	3,225	2,780	3,330	3,041	4,300
24	1,514	2,498	1,544	3,225	2,018	3,330	2,058	4,300
32	1,148	2,498	1,169	3,225	1,530	3,330	1,558	4,300
40	926	2,498	941	3,225	1,234	3,330	1,254	4,300
48	776	2,498	788	3,225	1,034	3,330	1,050	4,300
56	665	2,141	675	2,764	886	2,854	900	3,685
64	582	1,873	591	2,418	776	2,497	788	3,224
72	517	1,665	525	2,150	689	2,220	700	2,866
80	465	1,498	472	1,935	620	1,997	629	2,580
88	423	1,362	429	1,759	564	1,816	572	2,345
96	388	1,249	394	1,612	517	1,665	525	2,149
104	358	1,152	363	1,488	477	1,536	484	1,984
112	332	1,070	337	1,382	442	1,426	449	1,842
120	310	999	315	1,290	413	1,332	420	1,720

**Table 2-25: Out-of-Plane Bending Moment and Shear Capacity for Reinforced Masonry**

Nominal Thickness = 8 in.  
 Bar Size = No. 6  
 Reinforcement = Grade 60  
 Effective Depth = 3.813 in.

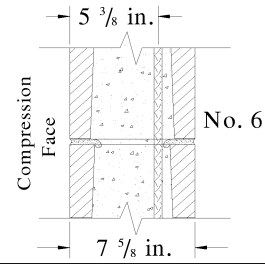
Note: When steel spacing exceeds 6 times the wall thickness or 72 inches, the portion of masonry spanning between bars shall be designed as unreinforced.



$f_m$ (psi) =	Load Combinations Not Including Wind or Seismic				Load Combinations Including Wind or Seismic			
	1,500		2,500		1,500		2,500	
	$M_R$ (ft-lb/ft)	$V_R$ (lb/ft)	$M_R$ (ft-lb/ft)	$V_R$ (lb/ft)	$M_R$ (ft-lb/ft)	$V_R$ (lb/ft)	$M_R$ (ft-lb/ft)	$V_R$ (lb/ft)
8	1,600	1,771	2,323	2,287	2,133	2,361	3,097	3,049
16	1,320	1,771	1,863	2,287	1,760	2,361	2,484	3,049
24	1,158	1,771	1,512	2,287	1,544	2,361	2,016	3,049
32	1,049	1,771	1,148	2,287	1,398	2,361	1,530	3,049
40	907	1,771	926	2,287	1,209	2,361	1,234	3,049
48	762	1,771	777	2,287	1,016	2,361	1,036	3,049
56	653	1,518	666	1,960	870	2,024	888	2,613
64	571	1,328	582	1,715	761	1,770	776	2,286
72	508	1,180	518	1,524	677	1,573	690	2,032
80	457	1,062	466	1,372	609	1,416	621	1,829
88	415	966	423	1,247	553	1,288	564	1,662
96	381	885	388	1,143	508	1,180	517	1,524
104	351	817	358	1,055	468	1,089	477	1,406
112	326	759	333	980	434	1,012	444	1,306
120	304	708	310	914	405	944	413	1,218

Nominal Thickness = 8 in.  
 Bar Size = No. 6  
 Reinforcement = Grade 60  
 Effective Depth = 5.375 in.

Note: When steel spacing exceeds 6 times the wall thickness or 72 inches, the portion of masonry spanning between bars shall be designed as unreinforced.

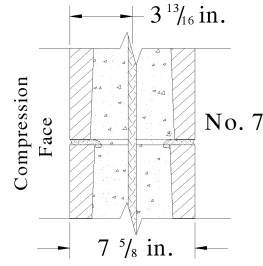


$f_m$ (psi) =	Load Combinations Not Including Wind or Seismic				Load Combinations Including Wind or Seismic			
	1,500		2,500		1,500		2,500	
	$M_R$ (ft-lb/ft)	$V_R$ (lb/ft)	$M_R$ (ft-lb/ft)	$V_R$ (lb/ft)	$M_R$ (ft-lb/ft)	$V_R$ (lb/ft)	$M_R$ (ft-lb/ft)	$V_R$ (lb/ft)
8	2,905	2,498	4,158	3,225	3,873	3,330	5,544	4,300
16	2,351	2,498	3,189	3,225	3,134	3,330	4,252	4,300
24	2,044	2,498	2,163	3,225	2,725	3,330	2,884	4,300
32	1,607	2,498	1,640	3,225	2,142	3,330	2,186	4,300
40	1,298	2,498	1,322	3,225	1,730	3,330	1,762	4,300
48	1,089	2,498	1,108	3,225	1,452	3,330	1,477	4,300
56	933	2,141	949	2,764	1,244	2,854	1,265	3,685
64	816	1,873	831	2,418	1,088	2,497	1,108	3,224
72	726	1,665	738	2,150	968	2,220	984	2,866
80	653	1,498	664	1,935	870	1,997	885	2,580
88	594	1,362	604	1,759	792	1,816	805	2,345
96	544	1,249	554	1,612	725	1,665	738	2,149
104	502	1,152	511	1,488	669	1,536	681	1,984
112	466	1,070	474	1,382	621	1,426	632	1,842
120	435	999	443	1,290	580	1,332	590	1,720

**Table 2-26: Out-of-Plane Bending Moment and Shear Capacity for Reinforced Masonry**

Nominal Thickness = 8 in.  
 Bar Size = No. 7  
 Reinforcement = Grade 60  
 Effective Depth = 3.813 in.

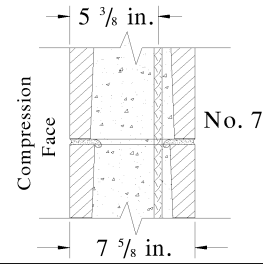
Note: When steel spacing exceeds 6 times the wall thickness or 72 inches, the portion of masonry spanning between bars shall be designed as unreinforced.



$f_m$ (psi) =	Load Combinations Not Including Wind or Seismic				Load Combinations Including Wind or Seismic			
	1,500		2,500		1,500		2,500	
	$M_R$ (ft-lb/ft)	$V_R$ (lb/ft)	$M_R$ (ft-lb/ft)	$V_R$ (lb/ft)	$M_R$ (ft-lb/ft)	$V_R$ (lb/ft)	$M_R$ (ft-lb/ft)	$V_R$ (lb/ft)
8	1,720	1,771	2,532	2,287	2,293	2,361	3,376	3,049
16	1,445	1,771	2,065	2,287	1,926	2,361	2,753	3,049
24	1,281	1,771	1,803	2,287	1,708	2,361	2,404	3,049
32	1,167	1,771	1,545	2,287	1,556	2,361	2,060	3,049
40	1,082	1,771	1,248	2,287	1,442	2,361	1,664	3,049
48	1,014	1,771	1,047	2,287	1,352	2,361	1,396	3,049
56	869	1,518	897	1,960	1,158	2,024	1,196	2,613
64	760	1,328	785	1,715	1,013	1,770	1,046	2,286
72	676	1,180	698	1,524	901	1,573	930	2,032
80	608	1,062	628	1,372	810	1,416	837	1,829
88	553	966	571	1,247	737	1,288	761	1,662
96	507	885	523	1,143	676	1,180	697	1,524
104	468	817	483	1,055	624	1,089	644	1,406
112	434	759	448	980	578	1,012	597	1,306
120	405	708	418	914	540	944	557	1,218

Nominal Thickness = 8 in.  
 Bar Size = No. 7  
 Reinforcement = Grade 60  
 Effective Depth = 5.375 in.

Note: When steel spacing exceeds 6 times the wall thickness or 72 inches, the portion of masonry spanning between bars shall be designed as unreinforced.

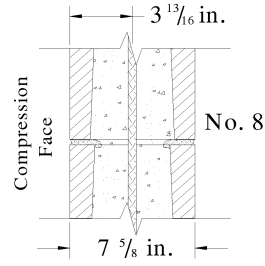


$f_m$ (psi) =	Load Combinations Not Including Wind or Seismic				Load Combinations Including Wind or Seismic			
	1,500		2,500		1,500		2,500	
	$M_R$ (ft-lb/ft)	$V_R$ (lb/ft)	$M_R$ (ft-lb/ft)	$V_R$ (lb/ft)	$M_R$ (ft-lb/ft)	$V_R$ (lb/ft)	$M_R$ (ft-lb/ft)	$V_R$ (lb/ft)
8	3,154	2,498	4,573	3,225	4,205	3,330	6,097	4,300
16	2,597	2,498	3,662	3,225	3,462	3,330	4,882	4,300
24	2,277	2,498	2,911	3,225	3,036	3,330	3,881	4,300
32	2,061	2,498	2,210	3,225	2,748	3,330	2,946	4,300
40	1,747	2,498	1,783	3,225	2,329	3,330	2,377	4,300
48	1,467	2,498	1,496	3,225	1,956	3,330	1,994	4,300
56	1,257	2,141	1,282	2,764	1,676	2,854	1,709	3,685
64	1,100	1,873	1,122	2,418	1,466	2,497	1,496	3,224
72	978	1,665	997	2,150	1,304	2,220	1,329	2,866
80	880	1,498	897	1,935	1,173	1,997	1,196	2,580
88	800	1,362	816	1,759	1,066	1,816	1,088	2,345
96	733	1,249	748	1,612	977	1,665	997	2,149
104	677	1,152	690	1,488	902	1,536	920	1,984
112	628	1,070	641	1,382	837	1,426	854	1,842
120	586	999	598	1,290	781	1,332	797	1,720

**Table 2-27: Out-of-Plane Bending Moment and Shear Capacity for Reinforced Masonry**

Nominal Thickness = 8 in.  
 Bar Size = No. 8  
 Reinforcement = Grade 60  
 Effective Depth = 3.813 in.

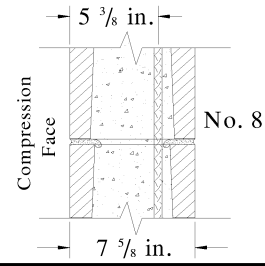
Note: When steel spacing exceeds 6 times the wall thickness or 72 inches, the portion of masonry spanning between bars shall be designed as unreinforced.



$f_m$ (psi) =	Load Combinations Not Including Wind or Seismic				Load Combinations Including Wind or Seismic			
	1,500		2,500		1,500		2,500	
	$M_R$ (ft-lb/ft)	$V_R$ (lb/ft)	$M_R$ (ft-lb/ft)	$V_R$ (lb/ft)	$M_R$ (ft-lb/ft)	$V_R$ (lb/ft)	$M_R$ (ft-lb/ft)	$V_R$ (lb/ft)
8	1,821	1,771	2,715	2,287	2,428	2,361	3,620	3,049
16	1,557	1,771	2,250	2,287	2,076	2,361	3,000	3,049
24	1,392	1,771	1,980	2,287	1,856	2,361	2,640	3,049
32	1,276	1,771	1,795	2,287	1,701	2,361	2,393	3,049
40	1,188	1,771	1,623	2,287	1,584	2,361	2,164	3,049
48	1,117	1,771	1,364	2,287	1,489	2,361	1,818	3,049
56	957	1,518	1,169	1,960	1,276	2,024	1,558	2,613
64	837	1,328	1,023	1,715	1,116	1,770	1,364	2,286
72	744	1,180	909	1,524	992	1,573	1,212	2,032
80	670	1,062	818	1,372	893	1,416	1,090	1,829
88	609	966	744	1,247	812	1,288	992	1,662
96	558	885	682	1,143	744	1,180	909	1,524
104	515	817	629	1,055	686	1,089	838	1,406
112	478	759	584	980	637	1,012	778	1,306
120	446	708	545	914	594	944	726	1,218

Nominal Thickness = 8 in.  
 Bar Size = No. 8  
 Reinforcement = Grade 60  
 Effective Depth = 5.375 in.

Note: When steel spacing exceeds 6 times the wall thickness or 72 inches, the portion of masonry spanning between bars shall be designed as unreinforced.

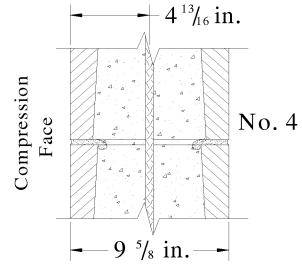


$f_m$ (psi) =	Load Combinations Not Including Wind or Seismic				Load Combinations Including Wind or Seismic			
	1,500		2,500		1,500		2,500	
	$M_R$ (ft-lb/ft)	$V_R$ (lb/ft)	$M_R$ (ft-lb/ft)	$V_R$ (lb/ft)	$M_R$ (ft-lb/ft)	$V_R$ (lb/ft)	$M_R$ (ft-lb/ft)	$V_R$ (lb/ft)
8	3,368	2,498	4,943	3,225	4,490	3,330	6,590	4,300
16	2,818	2,498	4,016	3,225	3,757	3,330	5,354	4,300
24	2,493	2,498	3,499	3,225	3,324	3,330	4,665	4,300
32	2,268	2,498	2,876	3,225	3,024	3,330	3,834	4,300
40	2,099	2,498	2,323	3,225	2,798	3,330	3,097	4,300
48	1,908	2,498	1,950	3,225	2,544	3,330	2,600	4,300
56	1,635	2,141	1,671	2,764	2,180	2,854	2,228	3,685
64	1,431	1,873	1,462	2,418	1,908	2,497	1,949	3,224
72	1,272	1,665	1,300	2,150	1,696	2,220	1,733	2,866
80	1,144	1,498	1,170	1,935	1,525	1,997	1,560	2,580
88	1,040	1,362	1,063	1,759	1,386	1,816	1,417	2,345
96	954	1,249	975	1,612	1,272	1,665	1,300	2,149
104	880	1,152	900	1,488	1,173	1,536	1,200	1,984
112	817	1,070	835	1,382	1,089	1,426	1,113	1,842
120	763	999	780	1,290	1,017	1,332	1,040	1,720

**Table 2-28: Out-of-Plane Bending Moment and Shear Capacity for Reinforced Masonry**

Nominal Thickness = 10 in.  
 Bar Size = No. 4  
 Reinforcement = Grade 60  
 Effective Depth = 4.813 in.

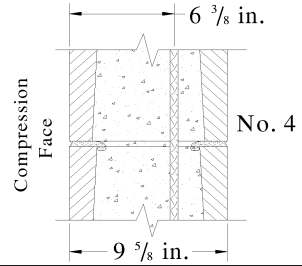
Note: When steel spacing exceeds 6 times the wall thickness or 72 inches, the portion of masonry spanning between bars shall be designed as unreinforced.



$f_m$ (psi) =	Load Combinations Not Including Wind or Seismic				Load Combinations Including Wind or Seismic			
	1,500		2,500		1,500		2,500	
	$M_R$ (ft-lb/ft)	$V_R$ (lb/ft)	$M_R$ (ft-lb/ft)	$V_R$ (lb/ft)	$M_R$ (ft-lb/ft)	$V_R$ (lb/ft)	$M_R$ (ft-lb/ft)	$V_R$ (lb/ft)
8	1,894	2,236	2,593	2,887	2,525	2,981	3,457	3,849
16	1,307	2,236	1,334	2,887	1,742	2,981	1,778	3,849
24	886	2,236	901	2,887	1,181	2,981	1,201	3,849
32	671	2,236	681	2,887	894	2,981	908	3,849
40	540	2,236	548	2,887	720	2,981	730	3,849
48	453	2,236	459	2,887	604	2,981	612	3,849
56	390	2,236	394	2,887	520	2,981	525	3,849
64	365	2,096	369	2,706	486	2,794	492	3,608
72	325	1,863	328	2,405	433	2,484	437	3,206
80	292	1,677	295	2,165	389	2,236	393	2,886
88	265	1,524	268	1,968	353	2,032	357	2,624
96	243	1,397	246	1,804	324	1,862	328	2,405
104	225	1,290	227	1,665	300	1,720	302	2,220
112	208	1,197	211	1,546	277	1,596	281	2,061
120	195	1,118	197	1,443	260	1,490	262	1,924

Nominal Thickness = 10 in.  
 Bar Size = No. 4  
 Reinforcement = Grade 60  
 Effective Depth = 6.375 in.

Note: When steel spacing exceeds 6 times the wall thickness or 72 inches, the portion of masonry spanning between bars shall be designed as unreinforced.



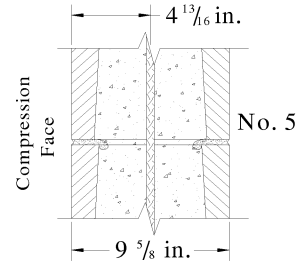
$f_m$ (psi) =	Load Combinations Not Including Wind or Seismic				Load Combinations Including Wind or Seismic			
	1,500		2,500		1,500		2,500	
	$M_R$ (ft-lb/ft)	$V_R$ (lb/ft)	$M_R$ (ft-lb/ft)	$V_R$ (lb/ft)	$M_R$ (ft-lb/ft)	$V_R$ (lb/ft)	$M_R$ (ft-lb/ft)	$V_R$ (lb/ft)
8	3,021	2,962	3,478	3,825	4,028	3,949	4,637	5,100
16	1,752	2,962	1,784	3,825	2,336	3,949	2,378	5,100
24	1,185	2,962	1,203	3,825	1,580	3,949	1,604	5,100
32	897	2,962	909	3,825	1,196	3,949	1,212	5,100
40	722	2,962	731	3,825	962	3,949	974	5,100
48	604	2,962	611	3,825	805	3,949	814	5,100
56	520	2,962	525	3,825	693	3,949	700	5,100
64	487	2,776	492	3,585	649	3,701	656	4,780
72	433	2,468	437	3,187	577	3,290	582	4,249
80	390	2,221	393	2,868	520	2,961	524	3,824
88	354	2,019	357	2,607	472	2,692	476	3,476
96	325	1,851	328	2,390	433	2,468	437	3,186
104	300	1,708	302	2,206	400	2,277	402	2,941
112	278	1,586	281	2,049	370	2,114	374	2,732
120	260	1,481	262	1,912	346	1,974	349	2,549



**Table 2-29: Out-of-Plane Bending Moment and Shear Capacity for Reinforced Masonry**

Nominal Thickness = 10 in.  
 Bar Size = No. 5  
 Reinforcement = Grade 60  
 Effective Depth = 4.813 in.

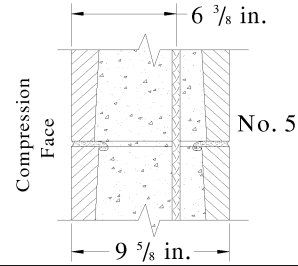
Note: When steel spacing exceeds 6 times the wall thickness or 72 inches, the portion of masonry spanning between bars shall be designed as unreinforced.



$f_m$ (psi) =	Load Combinations Not Including Wind or Seismic				Load Combinations Including Wind or Seismic			
	1,500		2,500		1,500		2,500	
	$M_R$ (ft-lb/ft)	$V_R$ (lb/ft)	$M_R$ (ft-lb/ft)	$V_R$ (lb/ft)	$M_R$ (ft-lb/ft)	$V_R$ (lb/ft)	$M_R$ (ft-lb/ft)	$V_R$ (lb/ft)
8	2,174	2,236	3,082	2,887	2,898	2,981	4,109	3,849
16	1,737	2,236	2,033	2,887	2,316	2,981	2,710	3,849
24	1,349	2,236	1,377	2,887	1,798	2,981	1,836	3,849
32	1,024	2,236	1,043	2,887	1,365	2,981	1,390	3,849
40	826	2,236	840	2,887	1,101	2,981	1,120	3,849
48	692	2,236	703	2,887	922	2,981	937	3,849
56	596	2,236	605	2,887	794	2,981	806	3,849
64	558	2,096	567	2,706	744	2,794	756	3,608
72	496	1,863	504	2,405	661	2,484	672	3,206
80	447	1,677	453	2,165	596	2,236	604	2,886
88	406	1,524	412	1,968	541	2,032	549	2,624
96	372	1,397	378	1,804	496	1,862	504	2,405
104	343	1,290	349	1,665	457	1,720	465	2,220
112	319	1,197	324	1,546	425	1,596	432	2,061
120	298	1,118	302	1,443	397	1,490	402	1,924

Nominal Thickness = 10 in.  
 Bar Size = No. 5  
 Reinforcement = Grade 60  
 Effective Depth = 6.375 in.

Note: When steel spacing exceeds 6 times the wall thickness or 72 inches, the portion of masonry spanning between bars shall be designed as unreinforced.

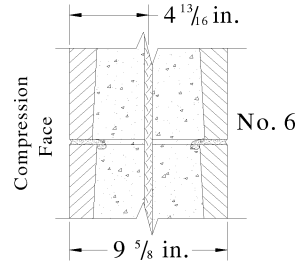


$f_m$ (psi) =	Load Combinations Not Including Wind or Seismic				Load Combinations Including Wind or Seismic			
	1,500		2,500		1,500		2,500	
	$M_R$ (ft-lb/ft)	$V_R$ (lb/ft)	$M_R$ (ft-lb/ft)	$V_R$ (lb/ft)	$M_R$ (ft-lb/ft)	$V_R$ (lb/ft)	$M_R$ (ft-lb/ft)	$V_R$ (lb/ft)
8	3,498	2,962	4,909	3,825	4,664	3,949	6,545	5,100
16	2,666	2,962	2,723	3,825	3,554	3,949	3,630	5,100
24	1,808	2,962	1,841	3,825	2,410	3,949	2,454	5,100
32	1,371	2,962	1,393	3,825	1,828	3,949	1,857	5,100
40	1,105	2,962	1,121	3,825	1,473	3,949	1,494	5,100
48	926	2,962	939	3,825	1,234	3,949	1,252	5,100
56	797	2,962	807	3,825	1,062	3,949	1,076	5,100
64	747	2,776	756	3,585	996	3,701	1,008	4,780
72	664	2,468	672	3,187	885	3,290	896	4,249
80	597	2,221	605	2,868	796	2,961	806	3,824
88	543	2,019	550	2,607	724	2,692	733	3,476
96	498	1,851	504	2,390	664	2,468	672	3,186
104	459	1,708	465	2,206	612	2,277	620	2,941
112	426	1,586	432	2,049	568	2,114	576	2,732
120	398	1,481	403	1,912	530	1,974	537	2,549

**Table 2-30: Out-of-Plane Bending Moment and Shear Capacity for Reinforced Masonry**

Nominal Thickness = 10 in.  
 Bar Size = No. 6  
 Reinforcement = Grade 60  
 Effective Depth = 4.813 in.

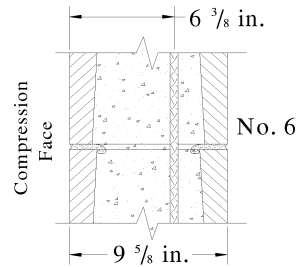
Note: When steel spacing exceeds 6 times the wall thickness or 72 inches, the portion of masonry spanning between bars shall be designed as unreinforced.



$f_m$ (psi) =	Load Combinations Not Including Wind or Seismic				Load Combinations Including Wind or Seismic			
	1,500		2,500		1,500		2,500	
	$M_R$ (ft-lb/ft)	$V_R$ (lb/ft)	$M_R$ (ft-lb/ft)	$V_R$ (lb/ft)	$M_R$ (ft-lb/ft)	$V_R$ (lb/ft)	$M_R$ (ft-lb/ft)	$V_R$ (lb/ft)
8	2,400	2,236	3,451	2,887	3,200	2,981	4,601	3,849
16	1,954	2,236	2,736	2,887	2,605	2,981	3,648	3,849
24	1,704	2,236	1,928	2,887	2,272	2,981	2,570	3,849
32	1,432	2,236	1,462	2,887	1,909	2,981	1,949	3,849
40	1,156	2,236	1,179	2,887	1,541	2,981	1,572	3,849
48	971	2,236	988	2,887	1,294	2,981	1,317	3,849
56	837	2,236	851	2,887	1,116	2,981	1,134	3,849
64	784	2,096	797	2,706	1,045	2,794	1,062	3,608
72	697	1,863	709	2,405	929	2,484	945	3,206
80	627	1,677	638	2,165	836	2,236	850	2,886
88	570	1,524	580	1,968	760	2,032	773	2,624
96	523	1,397	531	1,804	697	1,862	708	2,405
104	482	1,290	490	1,665	642	1,720	653	2,220
112	448	1,197	455	1,546	597	1,596	606	2,061
120	418	1,118	425	1,443	557	1,490	566	1,924

Nominal Thickness = 10 in.  
 Bar Size = No. 6  
 Reinforcement = Grade 60  
 Effective Depth = 6.375 in.

Note: When steel spacing exceeds 6 times the wall thickness or 72 inches, the portion of masonry spanning between bars shall be designed as unreinforced.

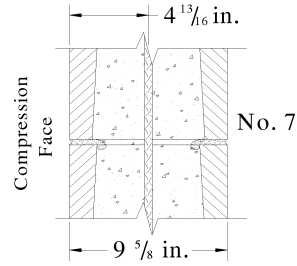


$f_m$ (psi) =	Load Combinations Not Including Wind or Seismic				Load Combinations Including Wind or Seismic			
	1,500		2,500		1,500		2,500	
	$M_R$ (ft-lb/ft)	$V_R$ (lb/ft)	$M_R$ (ft-lb/ft)	$V_R$ (lb/ft)	$M_R$ (ft-lb/ft)	$V_R$ (lb/ft)	$M_R$ (ft-lb/ft)	$V_R$ (lb/ft)
8	3,893	2,962	5,535	3,825	5,190	3,949	7,380	5,100
16	3,123	2,962	3,811	3,825	4,164	3,949	5,081	5,100
24	2,529	2,962	2,582	3,825	3,372	3,949	3,442	5,100
32	1,920	2,962	1,956	3,825	2,560	3,949	2,608	5,100
40	1,549	2,962	1,576	3,825	2,065	3,949	2,101	5,100
48	1,299	2,962	1,320	3,825	1,732	3,949	1,760	5,100
56	1,119	2,962	1,136	3,825	1,492	3,949	1,514	5,100
64	1,049	2,776	1,065	3,585	1,398	3,701	1,420	4,780
72	932	2,468	946	3,187	1,242	3,290	1,261	4,249
80	839	2,221	852	2,868	1,118	2,961	1,136	3,824
88	762	2,019	774	2,607	1,016	2,692	1,032	3,476
96	699	1,851	710	2,390	932	2,468	946	3,186
104	645	1,708	655	2,206	860	2,277	873	2,941
112	599	1,586	608	2,049	798	2,114	810	2,732
120	559	1,481	568	1,912	745	1,974	757	2,549

**Table 2-31: Out-of-Plane Bending Moment and Shear Capacity for Reinforced Masonry**

Nominal Thickness = 10 in.  
 Bar Size = No. 7  
 Reinforcement = Grade 60  
 Effective Depth = 4.813 in.

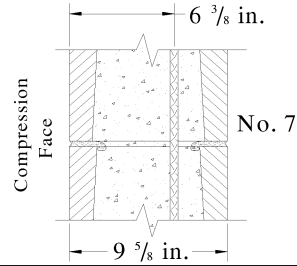
Note: When steel spacing exceeds 6 times the wall thickness or 72 inches, the portion of masonry spanning between bars shall be designed as unreinforced.



$f_m$ (psi) =	Load Combinations Not Including Wind or Seismic				Load Combinations Including Wind or Seismic			
	1,500		2,500		1,500		2,500	
	$M_R$ (ft-lb/ft)	$V_R$ (lb/ft)	$M_R$ (ft-lb/ft)	$V_R$ (lb/ft)	$M_R$ (ft-lb/ft)	$V_R$ (lb/ft)	$M_R$ (ft-lb/ft)	$V_R$ (lb/ft)
8	2,598	2,236	3,785	2,887	3,464	2,981	5,046	3,849
16	2,153	2,236	3,048	2,887	2,870	2,981	4,064	3,849
24	1,894	2,236	2,593	2,887	2,525	2,981	3,457	3,849
32	1,718	2,236	1,970	2,887	2,290	2,981	2,626	3,849
40	1,556	2,236	1,590	2,887	2,074	2,981	2,120	3,849
48	1,307	2,236	1,334	2,887	1,742	2,981	1,778	3,849
56	1,128	2,236	1,149	2,887	1,504	2,981	1,532	3,849
64	1,057	2,096	1,077	2,706	1,409	2,794	1,436	3,608
72	940	1,863	957	2,405	1,253	2,484	1,276	3,206
80	846	1,677	861	2,165	1,128	2,236	1,148	2,886
88	769	1,524	783	1,968	1,025	2,032	1,044	2,624
96	705	1,397	718	1,804	940	1,862	957	2,405
104	650	1,290	662	1,665	866	1,720	882	2,220
112	604	1,197	615	1,546	805	1,596	820	2,061
120	564	1,118	574	1,443	752	1,490	765	1,924

Nominal Thickness = 10 in.  
 Bar Size = No. 7  
 Reinforcement = Grade 60  
 Effective Depth = 6.375 in.

Note: When steel spacing exceeds 6 times the wall thickness or 72 inches, the portion of masonry spanning between bars shall be designed as unreinforced.

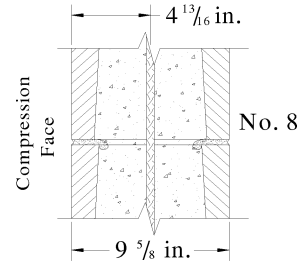


$f_m$ (psi) =	Load Combinations Not Including Wind or Seismic				Load Combinations Including Wind or Seismic			
	1,500		2,500		1,500		2,500	
	$M_R$ (ft-lb/ft)	$V_R$ (lb/ft)	$M_R$ (ft-lb/ft)	$V_R$ (lb/ft)	$M_R$ (ft-lb/ft)	$V_R$ (lb/ft)	$M_R$ (ft-lb/ft)	$V_R$ (lb/ft)
8	4,245	2,962	6,111	3,825	5,660	3,949	8,148	5,100
16	3,462	2,962	4,852	3,825	4,616	3,949	6,469	5,100
24	3,021	2,962	3,478	3,825	4,028	3,949	4,637	5,100
32	2,583	2,962	2,639	3,825	3,444	3,949	3,518	5,100
40	2,087	2,962	2,128	3,825	2,782	3,949	2,837	5,100
48	1,752	2,962	1,784	3,825	2,336	3,949	2,378	5,100
56	1,510	2,962	1,536	3,825	2,013	3,949	2,048	5,100
64	1,415	2,776	1,440	3,585	1,886	3,701	1,920	4,780
72	1,258	2,468	1,280	3,187	1,677	3,290	1,706	4,249
80	1,132	2,221	1,152	2,868	1,509	2,961	1,536	3,824
88	1,029	2,019	1,047	2,607	1,372	2,692	1,396	3,476
96	943	1,851	960	2,390	1,257	2,468	1,280	3,186
104	871	1,708	886	2,206	1,161	2,277	1,181	2,941
112	808	1,586	822	2,049	1,077	2,114	1,096	2,732
120	755	1,481	768	1,912	1,006	1,974	1,024	2,549

**Table 2-32: Out-of-Plane Bending Moment and Shear Capacity for Reinforced Masonry**

Nominal Thickness = 10 in.  
 Bar Size = No. 8  
 Reinforcement = Grade 60  
 Effective Depth = 4.813 in.

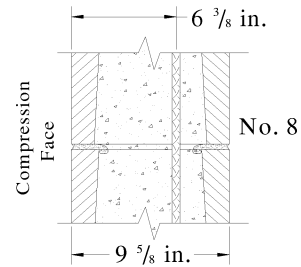
Note: When steel spacing exceeds 6 times the wall thickness or 72 inches, the portion of masonry spanning between bars shall be designed as unreinforced.



$f_m$ (psi) =	Load Combinations Not Including Wind or Seismic				Load Combinations Including Wind or Seismic			
	1,500		2,500		1,500		2,500	
	$M_R$ (ft-lb/ft)	$V_R$ (lb/ft)	$M_R$ (ft-lb/ft)	$V_R$ (lb/ft)	$M_R$ (ft-lb/ft)	$V_R$ (lb/ft)	$M_R$ (ft-lb/ft)	$V_R$ (lb/ft)
8	2,766	2,236	4,081	2,887	3,688	2,981	5,441	3,849
16	2,331	2,236	3,336	2,887	3,108	2,981	4,448	3,849
24	2,069	2,236	2,915	2,887	2,758	2,981	3,886	3,849
32	1,886	2,236	2,562	2,887	2,514	2,981	3,416	3,849
40	1,749	2,236	2,070	2,887	2,332	2,981	2,760	3,849
48	1,640	2,236	1,738	2,887	2,186	2,981	2,317	3,849
56	1,467	2,236	1,499	2,887	1,956	2,981	1,998	3,849
64	1,375	2,096	1,405	2,706	1,833	2,794	1,873	3,608
72	1,222	1,863	1,249	2,405	1,629	2,484	1,665	3,206
80	1,100	1,677	1,124	2,165	1,466	2,236	1,498	2,886
88	1,000	1,524	1,022	1,968	1,333	2,032	1,362	2,624
96	916	1,397	936	1,804	1,221	1,862	1,248	2,405
104	846	1,290	864	1,665	1,128	1,720	1,152	2,220
112	785	1,197	803	1,546	1,046	1,596	1,070	2,061
120	733	1,118	749	1,443	977	1,490	998	1,924

Nominal Thickness = 10 in.  
 Bar Size = No. 8  
 Reinforcement = Grade 60  
 Effective Depth = 6.375 in.

Note: When steel spacing exceeds 6 times the wall thickness or 72 inches, the portion of masonry spanning between bars shall be designed as unreinforced.

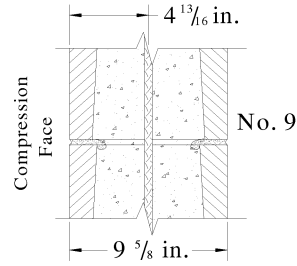


$f_m$ (psi) =	Load Combinations Not Including Wind or Seismic				Load Combinations Including Wind or Seismic			
	1,500		2,500		1,500		2,500	
	$M_R$ (ft-lb/ft)	$V_R$ (lb/ft)	$M_R$ (ft-lb/ft)	$V_R$ (lb/ft)	$M_R$ (ft-lb/ft)	$V_R$ (lb/ft)	$M_R$ (ft-lb/ft)	$V_R$ (lb/ft)
8	4,552	2,962	6,630	3,825	6,069	3,949	8,840	5,100
16	3,771	2,962	5,338	3,825	5,028	3,949	7,117	5,100
24	3,318	2,962	4,525	3,825	4,424	3,949	6,033	5,100
32	3,008	2,962	3,437	3,825	4,010	3,949	4,582	5,100
40	2,715	2,962	2,774	3,825	3,620	3,949	3,698	5,100
48	2,281	2,962	2,327	3,825	3,041	3,949	3,102	5,100
56	1,968	2,962	2,005	3,825	2,624	3,949	2,673	5,100
64	1,845	2,776	1,879	3,585	2,460	3,701	2,505	4,780
72	1,640	2,468	1,670	3,187	2,186	3,290	2,226	4,249
80	1,476	2,221	1,503	2,868	1,968	2,961	2,004	3,824
88	1,341	2,019	1,367	2,607	1,788	2,692	1,822	3,476
96	1,230	1,851	1,253	2,390	1,640	2,468	1,670	3,186
104	1,135	1,708	1,156	2,206	1,513	2,277	1,541	2,941
112	1,054	1,586	1,074	2,049	1,405	2,114	1,432	2,732
120	984	1,481	1,002	1,912	1,312	1,974	1,336	2,549

**Table 2-33: Out-of-Plane Bending Moment and Shear Capacity for Reinforced Masonry**

Nominal Thickness = 10 in.  
 Bar Size = No. 9  
 Reinforcement = Grade 60  
 Effective Depth = 4.813 in.

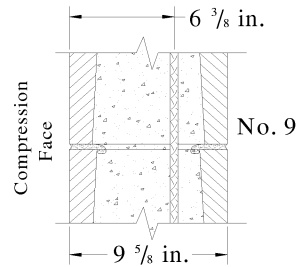
Note: When steel spacing exceeds 6 times the wall thickness or 72 inches, the portion of masonry spanning between bars shall be designed as unreinforced.



$f_m$ (psi) =	Load Combinations Not Including Wind or Seismic				Load Combinations Including Wind or Seismic			
	1,500		2,500		1,500		2,500	
	$M_R$ (ft-lb/ft)	$V_R$ (lb/ft)	$M_R$ (ft-lb/ft)	$V_R$ (lb/ft)	$M_R$ (ft-lb/ft)	$V_R$ (lb/ft)	$M_R$ (ft-lb/ft)	$V_R$ (lb/ft)
8	2,904	2,236	4,330	2,887	3,872	2,981	5,773	3,849
16	2,482	2,236	3,588	2,887	3,309	2,981	4,784	3,849
24	2,221	2,236	3,157	2,887	2,961	2,981	4,209	3,849
32	2,036	2,236	2,863	2,887	2,714	2,981	3,817	3,849
40	1,894	2,236	2,593	2,887	2,525	2,981	3,457	3,849
48	1,782	2,236	2,179	2,887	2,376	2,981	2,905	3,849
56	1,688	2,236	1,880	2,887	2,250	2,981	2,506	3,849
64	1,582	2,096	1,762	2,706	2,109	2,794	2,349	3,608
72	1,406	1,863	1,566	2,405	1,874	2,484	2,088	3,206
80	1,266	1,677	1,410	2,165	1,688	2,236	1,880	2,886
88	1,150	1,524	1,281	1,968	1,533	2,032	1,708	2,624
96	1,055	1,397	1,175	1,804	1,406	1,862	1,566	2,405
104	973	1,290	1,084	1,665	1,297	1,720	1,445	2,220
112	904	1,197	1,007	1,546	1,205	1,596	1,342	2,061
120	844	1,118	940	1,443	1,125	1,490	1,253	1,924

Nominal Thickness = 10 in.  
 Bar Size = No. 9  
 Reinforcement = Grade 60  
 Effective Depth = 6.375 in.

Note: When steel spacing exceeds 6 times the wall thickness or 72 inches, the portion of masonry spanning between bars shall be designed as unreinforced.

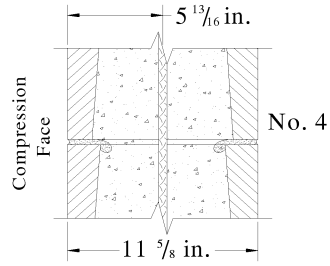


$f_m$ (psi) =	Load Combinations Not Including Wind or Seismic				Load Combinations Including Wind or Seismic			
	1,500		2,500		1,500		2,500	
	$M_R$ (ft-lb/ft)	$V_R$ (lb/ft)	$M_R$ (ft-lb/ft)	$V_R$ (lb/ft)	$M_R$ (ft-lb/ft)	$V_R$ (lb/ft)	$M_R$ (ft-lb/ft)	$V_R$ (lb/ft)
8	4,807	2,962	7,076	3,825	6,409	3,949	9,434	5,100
16	4,039	2,962	5,770	3,825	5,385	3,949	7,693	5,100
24	3,580	2,962	5,036	3,825	4,773	3,949	6,714	5,100
32	3,261	2,962	4,306	3,825	4,348	3,949	5,741	5,100
40	3,021	2,962	3,478	3,825	4,028	3,949	4,637	5,100
48	2,832	2,962	2,920	3,825	3,776	3,949	3,893	5,100
56	2,466	2,962	2,518	3,825	3,288	3,949	3,357	5,100
64	2,311	2,776	2,360	3,585	3,081	3,701	3,146	4,780
72	2,055	2,468	2,098	3,187	2,740	3,290	2,797	4,249
80	1,849	2,221	1,888	2,868	2,465	2,961	2,517	3,824
88	1,681	2,019	1,716	2,607	2,241	2,692	2,288	3,476
96	1,541	1,851	1,573	2,390	2,054	2,468	2,097	3,186
104	1,422	1,708	1,452	2,206	1,896	2,277	1,936	2,941
112	1,321	1,586	1,348	2,049	1,761	2,114	1,797	2,732
120	1,233	1,481	1,259	1,912	1,644	1,974	1,678	2,549

**Table 2-34: Out-of-Plane Bending Moment and Shear Capacity for Reinforced Masonry**

Nominal Thickness = 12 in.  
 Bar Size = No. 4  
 Reinforcement = Grade 60  
 Effective Depth = 5.813 in.

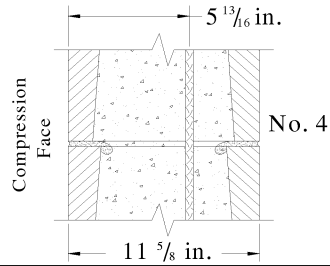
Note: When steel spacing exceeds 6 times the wall thickness or 72 inches, the portion of masonry spanning between bars shall be designed as unreinforced.



$f_m$ (psi) =	Load Combinations Not Including Wind or Seismic				Load Combinations Including Wind or Seismic			
	1,500		2,500		1,500		2,500	
	$M_R$ (ft-lb/ft)	$V_R$ (lb/ft)	$M_R$ (ft-lb/ft)	$V_R$ (lb/ft)	$M_R$ (ft-lb/ft)	$V_R$ (lb/ft)	$M_R$ (ft-lb/ft)	$V_R$ (lb/ft)
8	2,593	2,701	3,159	3,487	3,457	3,601	4,212	4,649
16	1,591	2,701	1,622	3,487	2,121	3,601	2,162	4,649
24	1,077	2,701	1,094	3,487	1,436	3,601	1,458	4,649
32	815	2,701	827	3,487	1,086	3,601	1,102	4,649
40	656	2,701	665	3,487	874	3,601	886	4,649
48	550	2,701	556	3,487	733	3,601	741	4,649
56	473	2,701	478	3,487	630	3,601	637	4,649
64	415	2,701	419	3,487	553	3,601	558	4,649
72	370	2,701	373	3,487	493	3,601	497	4,649
80	333	2,430	335	3,138	444	3,240	446	4,184
88	302	2,209	305	2,853	402	2,945	406	3,804
96	277	2,025	279	2,615	369	2,700	372	3,486
104	256	1,869	258	2,414	341	2,492	344	3,218
112	237	1,736	239	2,241	316	2,314	318	2,988
120	222	1,620	223	2,092	296	2,160	297	2,789

Nominal Thickness = 12 in.  
 Bar Size = No. 4  
 Reinforcement = Grade 60  
 Effective Depth = 7.375 in.

Note: When steel spacing exceeds 6 times the wall thickness or 72 inches, the portion of masonry spanning between bars shall be designed as unreinforced.

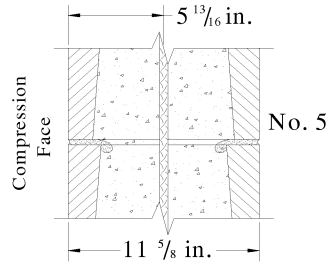


$f_m$ (psi) =	Load Combinations Not Including Wind or Seismic				Load Combinations Including Wind or Seismic			
	1,500		2,500		1,500		2,500	
	$M_R$ (ft-lb/ft)	$V_R$ (lb/ft)	$M_R$ (ft-lb/ft)	$V_R$ (lb/ft)	$M_R$ (ft-lb/ft)	$V_R$ (lb/ft)	$M_R$ (ft-lb/ft)	$V_R$ (lb/ft)
8	3,840	3,427	4,048	4,425	5,120	4,569	5,397	5,900
16	2,038	3,427	2,073	4,425	2,717	4,569	2,764	5,900
24	1,377	3,427	1,397	4,425	1,836	4,569	1,862	5,900
32	1,042	3,427	1,055	4,425	1,389	4,569	1,406	5,900
40	838	3,427	848	4,425	1,117	4,569	1,130	5,900
48	702	3,427	709	4,425	936	4,569	945	5,900
56	603	3,427	609	4,425	804	4,569	812	5,900
64	529	3,427	534	4,425	705	4,569	712	5,900
72	472	3,427	476	4,425	629	4,569	634	5,900
80	424	3,084	428	3,982	565	4,112	570	5,309
88	386	2,803	389	3,620	514	3,737	518	4,826
96	354	2,570	357	3,318	472	3,426	476	4,424
104	326	2,372	329	3,063	434	3,162	438	4,084
112	303	2,203	306	2,844	404	2,937	408	3,792
120	283	2,056	285	2,655	377	2,741	380	3,540

**Table 2-35: Out-of-Plane Bending Moment and Shear Capacity for Reinforced Masonry**

Nominal Thickness = 12 in.  
 Bar Size = No. 5  
 Reinforcement = Grade 60  
 Effective Depth = 5.813 in.

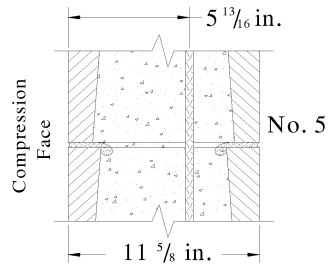
Note: When steel spacing exceeds 6 times the wall thickness or 72 inches, the portion of masonry spanning between bars shall be designed as unreinforced.



$f_m$ (psi) =	Load Combinations Not Including Wind or Seismic				Load Combinations Including Wind or Seismic			
	1,500		2,500		1,500		2,500	
	$M_R$ (ft-lb/ft)	$V_R$ (lb/ft)	$M_R$ (ft-lb/ft)	$V_R$ (lb/ft)	$M_R$ (ft-lb/ft)	$V_R$ (lb/ft)	$M_R$ (ft-lb/ft)	$V_R$ (lb/ft)
8	2,994	2,701	4,215	3,487	3,992	3,601	5,620	4,649
16	2,371	2,701	2,474	3,487	3,161	3,601	3,298	4,649
24	1,642	2,701	1,674	3,487	2,189	3,601	2,232	4,649
32	1,245	2,701	1,267	3,487	1,660	3,601	1,689	4,649
40	1,004	2,701	1,020	3,487	1,338	3,601	1,360	4,649
48	842	2,701	854	3,487	1,122	3,601	1,138	4,649
56	725	2,701	734	3,487	966	3,601	978	4,649
64	636	2,701	645	3,487	848	3,601	860	4,649
72	567	2,701	574	3,487	756	3,601	765	4,649
80	510	2,430	516	3,138	680	3,240	688	4,184
88	463	2,209	469	2,853	617	2,945	625	3,804
96	425	2,025	430	2,615	566	2,700	573	3,486
104	392	1,869	397	2,414	522	2,492	529	3,218
112	364	1,736	369	2,241	485	2,314	492	2,988
120	340	1,620	344	2,092	453	2,160	458	2,789

Nominal Thickness = 12 in.  
 Bar Size = No. 5  
 Reinforcement = Grade 60  
 Effective Depth = 7.375 in.

Note: When steel spacing exceeds 6 times the wall thickness or 72 inches, the portion of masonry spanning between bars shall be designed as unreinforced.

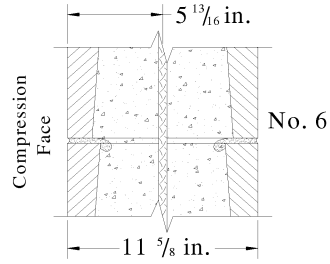


$f_m$ (psi) =	Load Combinations Not Including Wind or Seismic				Load Combinations Including Wind or Seismic			
	1,500		2,500		1,500		2,500	
	$M_R$ (ft-lb/ft)	$V_R$ (lb/ft)	$M_R$ (ft-lb/ft)	$V_R$ (lb/ft)	$M_R$ (ft-lb/ft)	$V_R$ (lb/ft)	$M_R$ (ft-lb/ft)	$V_R$ (lb/ft)
8	4,466	3,427	6,158	4,425	5,954	4,569	8,210	5,900
16	3,104	3,427	3,168	4,425	4,138	4,569	4,224	5,900
24	2,103	3,427	2,140	4,425	2,804	4,569	2,853	5,900
32	1,594	3,427	1,618	4,425	2,125	4,569	2,157	5,900
40	1,284	3,427	1,302	4,425	1,712	4,569	1,736	5,900
48	1,076	3,427	1,090	4,425	1,434	4,569	1,453	5,900
56	926	3,427	937	4,425	1,234	4,569	1,249	5,900
64	813	3,427	822	4,425	1,084	4,569	1,096	5,900
72	724	3,427	732	4,425	965	4,569	976	5,900
80	651	3,084	658	3,982	868	4,112	877	5,309
88	592	2,803	598	3,620	789	3,737	797	4,826
96	543	2,570	549	3,318	724	3,426	732	4,424
104	501	2,372	506	3,063	668	3,162	674	4,084
112	465	2,203	470	2,844	620	2,937	626	3,792
120	434	2,056	439	2,655	578	2,741	585	3,540

**Table 2-36: Out-of-Plane Bending Moment and Shear Capacity for Reinforced Masonry**

Nominal Thickness = 12 in.  
 Bar Size = No. 6  
 Reinforcement = Grade 60  
 Effective Depth = 5.813 in.

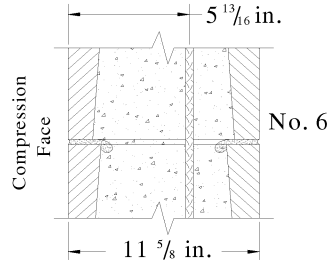
Note: When steel spacing exceeds 6 times the wall thickness or 72 inches, the portion of masonry spanning between bars shall be designed as unreinforced.



$f_m$ (psi) =	Load Combinations Not Including Wind or Seismic				Load Combinations Including Wind or Seismic			
	1,500		2,500		1,500		2,500	
	$M_R$ (ft-lb/ft)	$V_R$ (lb/ft)	$M_R$ (ft-lb/ft)	$V_R$ (lb/ft)	$M_R$ (ft-lb/ft)	$V_R$ (lb/ft)	$M_R$ (ft-lb/ft)	$V_R$ (lb/ft)
8	3,324	2,701	4,742	3,487	4,432	3,601	6,322	4,649
16	2,679	2,701	3,460	3,487	3,572	3,601	4,613	4,649
24	2,296	2,701	2,346	3,487	3,061	3,601	3,128	4,649
32	1,744	2,701	1,778	3,487	2,325	3,601	2,370	4,649
40	1,407	2,701	1,433	3,487	1,876	3,601	1,910	4,649
48	1,181	2,701	1,201	3,487	1,574	3,601	1,601	4,649
56	1,017	2,701	1,033	3,487	1,356	3,601	1,377	4,649
64	894	2,701	907	3,487	1,192	3,601	1,209	4,649
72	798	2,701	809	3,487	1,064	3,601	1,078	4,649
80	718	2,430	728	3,138	957	3,240	970	4,184
88	652	2,209	661	2,853	869	2,945	881	3,804
96	598	2,025	606	2,615	797	2,700	808	3,486
104	552	1,869	560	2,414	736	2,492	746	3,218
112	513	1,736	520	2,241	684	2,314	693	2,988
120	478	1,620	485	2,092	637	2,160	646	2,789

Nominal Thickness = 12 in.  
 Bar Size = No. 6  
 Reinforcement = Grade 60  
 Effective Depth = 7.375 in.

Note: When steel spacing exceeds 6 times the wall thickness or 72 inches, the portion of masonry spanning between bars shall be designed as unreinforced.



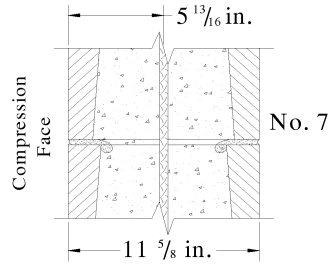
$f_m$ (psi) =	Load Combinations Not Including Wind or Seismic				Load Combinations Including Wind or Seismic			
	1,500		2,500		1,500		2,500	
	$M_R$ (ft-lb/ft)	$V_R$ (lb/ft)	$M_R$ (ft-lb/ft)	$V_R$ (lb/ft)	$M_R$ (ft-lb/ft)	$V_R$ (lb/ft)	$M_R$ (ft-lb/ft)	$V_R$ (lb/ft)
8	4,990	3,427	7,054	4,425	6,653	4,569	9,405	5,900
16	3,973	3,427	4,436	4,425	5,297	4,569	5,914	5,900
24	2,944	3,427	3,003	4,425	3,925	4,569	4,004	5,900
32	2,234	3,427	2,274	4,425	2,978	4,569	3,032	5,900
40	1,802	3,427	1,831	4,425	2,402	4,569	2,441	5,900
48	1,511	3,427	1,533	4,425	2,014	4,569	2,044	5,900
56	1,301	3,427	1,319	4,425	1,734	4,569	1,758	5,900
64	1,143	3,427	1,158	4,425	1,524	4,569	1,544	5,900
72	1,019	3,427	1,032	4,425	1,358	4,569	1,376	5,900
80	917	3,084	928	3,982	1,222	4,112	1,237	5,309
88	833	2,803	844	3,620	1,110	3,737	1,125	4,826
96	764	2,570	774	3,318	1,018	3,426	1,032	4,424
104	705	2,372	714	3,063	940	3,162	952	4,084
112	655	2,203	663	2,844	873	2,937	884	3,792
120	611	2,056	619	2,655	814	2,741	825	3,540



**Table 2-37: Out-of-Plane Bending Moment and Shear Capacity for Reinforced Masonry**

Nominal Thickness = 12 in.  
 Bar Size = No. 7  
 Reinforcement = Grade 60  
 Effective Depth = 5.813 in.

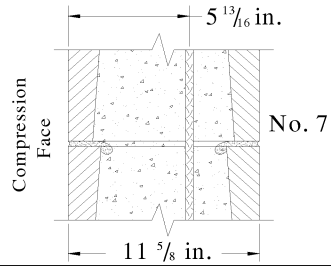
Note: When steel spacing exceeds 6 times the wall thickness or 72 inches, the portion of masonry spanning between bars shall be designed as unreinforced.



$f_m$ (psi) =	Load Combinations Not Including Wind or Seismic				Load Combinations Including Wind or Seismic			
	1,500		2,500		1,500		2,500	
	$M_R$ (ft-lb/ft)	$V_R$ (lb/ft)	$M_R$ (ft-lb/ft)	$V_R$ (lb/ft)	$M_R$ (ft-lb/ft)	$V_R$ (lb/ft)	$M_R$ (ft-lb/ft)	$V_R$ (lb/ft)
8	3,615	2,701	5,224	3,487	4,820	3,601	6,965	4,649
16	2,964	2,701	4,167	3,487	3,952	3,601	5,556	4,649
24	2,593	2,701	3,159	3,487	3,457	3,601	4,212	4,649
32	2,343	2,701	2,397	3,487	3,124	3,601	3,196	4,649
40	1,895	2,701	1,934	3,487	2,526	3,601	2,578	4,649
48	1,591	2,701	1,622	3,487	2,121	3,601	2,162	4,649
56	1,372	2,701	1,397	3,487	1,829	3,601	1,862	4,649
64	1,207	2,701	1,227	3,487	1,609	3,601	1,636	4,649
72	1,077	2,701	1,094	3,487	1,436	3,601	1,458	4,649
80	969	2,430	984	3,138	1,292	3,240	1,312	4,184
88	881	2,209	895	2,853	1,174	2,945	1,193	3,804
96	807	2,025	820	2,615	1,076	2,700	1,093	3,486
104	745	1,869	757	2,414	993	2,492	1,009	3,218
112	692	1,736	703	2,241	922	2,314	937	2,988
120	646	1,620	656	2,092	861	2,160	874	2,789

Nominal Thickness = 12 in.  
 Bar Size = No. 7  
 Reinforcement = Grade 60  
 Effective Depth = 7.375 in.

Note: When steel spacing exceeds 6 times the wall thickness or 72 inches, the portion of masonry spanning between bars shall be designed as unreinforced.

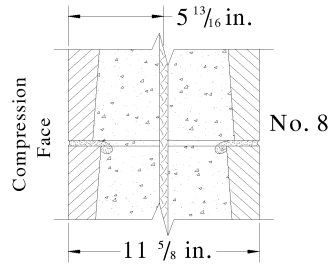


$f_m$ (psi) =	Load Combinations Not Including Wind or Seismic				Load Combinations Including Wind or Seismic			
	1,500		2,500		1,500		2,500	
	$M_R$ (ft-lb/ft)	$V_R$ (lb/ft)	$M_R$ (ft-lb/ft)	$V_R$ (lb/ft)	$M_R$ (ft-lb/ft)	$V_R$ (lb/ft)	$M_R$ (ft-lb/ft)	$V_R$ (lb/ft)
8	5,461	3,427	7,813	4,425	7,281	4,569	10,417	5,900
16	4,418	3,427	5,968	4,425	5,890	4,569	7,957	5,900
24	3,840	3,427	4,048	4,425	5,120	4,569	5,397	5,900
32	3,008	3,427	3,069	4,425	4,010	4,569	4,092	5,900
40	2,429	3,427	2,474	4,425	3,238	4,569	3,298	5,900
48	2,038	3,427	2,073	4,425	2,717	4,569	2,764	5,900
56	1,756	3,427	1,785	4,425	2,341	4,569	2,380	5,900
64	1,544	3,427	1,567	4,425	2,058	4,569	2,089	5,900
72	1,377	3,427	1,397	4,425	1,836	4,569	1,862	5,900
80	1,239	3,084	1,257	3,982	1,652	4,112	1,676	5,309
88	1,126	2,803	1,143	3,620	1,501	3,737	1,524	4,826
96	1,032	2,570	1,047	3,318	1,376	3,426	1,396	4,424
104	953	2,372	967	3,063	1,270	3,162	1,289	4,084
112	885	2,203	898	2,844	1,180	2,937	1,197	3,792
120	826	2,056	838	2,655	1,101	2,741	1,117	3,540

**Table 2-38: Out-of-Plane Bending Moment and Shear Capacity for Reinforced Masonry**

Nominal Thickness = 12 in.  
 Bar Size = No. 8  
 Reinforcement = Grade 60  
 Effective Depth = 5.813 in.

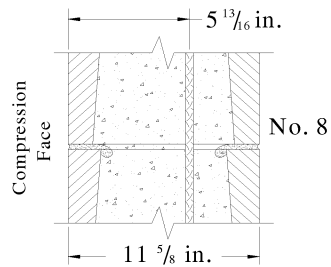
Note: When steel spacing exceeds 6 times the wall thickness or 72 inches, the portion of masonry spanning between bars shall be designed as unreinforced.



$f_m$ (psi) =	Load Combinations Not Including Wind or Seismic				Load Combinations Including Wind or Seismic			
	1,500		2,500		1,500		2,500	
	$M_R$ (ft-lb/ft)	$V_R$ (lb/ft)	$M_R$ (ft-lb/ft)	$V_R$ (lb/ft)	$M_R$ (ft-lb/ft)	$V_R$ (lb/ft)	$M_R$ (ft-lb/ft)	$V_R$ (lb/ft)
8	3,868	2,701	5,657	3,487	5,157	3,601	7,542	4,649
16	3,222	2,701	4,577	3,487	4,296	3,601	6,102	4,649
24	2,843	2,701	3,979	3,487	3,790	3,601	5,305	4,649
32	2,582	2,701	3,121	3,487	3,442	3,601	4,161	4,649
40	2,387	2,701	2,520	3,487	3,182	3,601	3,360	4,649
48	2,071	2,701	2,115	3,487	2,761	3,601	2,820	4,649
56	1,787	2,701	1,823	3,487	2,382	3,601	2,430	4,649
64	1,572	2,701	1,602	3,487	2,096	3,601	2,136	4,649
72	1,404	2,701	1,429	3,487	1,872	3,601	1,905	4,649
80	1,263	2,430	1,286	3,138	1,684	3,240	1,714	4,184
88	1,148	2,209	1,169	2,853	1,530	2,945	1,558	3,804
96	1,053	2,025	1,071	2,615	1,404	2,700	1,428	3,486
104	972	1,869	989	2,414	1,296	2,492	1,318	3,218
112	902	1,736	918	2,241	1,202	2,314	1,224	2,988
120	842	1,620	857	2,092	1,122	2,160	1,142	2,789

Nominal Thickness = 12 in.  
 Bar Size = No. 8  
 Reinforcement = Grade 60  
 Effective Depth = 7.375 in.

Note: When steel spacing exceeds 6 times the wall thickness or 72 inches, the portion of masonry spanning between bars shall be designed as unreinforced.

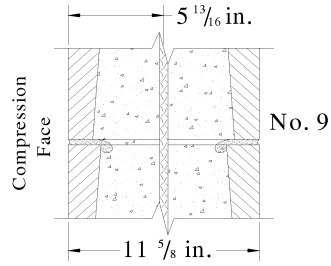


$f_m$ (psi) =	Load Combinations Not Including Wind or Seismic				Load Combinations Including Wind or Seismic			
	1,500		2,500		1,500		2,500	
	$M_R$ (ft-lb/ft)	$V_R$ (lb/ft)	$M_R$ (ft-lb/ft)	$V_R$ (lb/ft)	$M_R$ (ft-lb/ft)	$V_R$ (lb/ft)	$M_R$ (ft-lb/ft)	$V_R$ (lb/ft)
8	5,876	3,427	8,505	4,425	7,834	4,569	11,340	5,900
16	4,827	3,427	6,797	4,425	6,436	4,569	9,062	5,900
24	4,228	3,427	5,269	4,425	5,637	4,569	7,025	5,900
32	3,823	3,427	4,000	4,425	5,097	4,569	5,333	5,900
40	3,161	3,427	3,227	4,425	4,214	4,569	4,302	5,900
48	2,655	3,427	2,706	4,425	3,540	4,569	3,608	5,900
56	2,290	3,427	2,331	4,425	3,053	4,569	3,108	5,900
64	2,013	3,427	2,048	4,425	2,684	4,569	2,730	5,900
72	1,797	3,427	1,827	4,425	2,396	4,569	2,436	5,900
80	1,617	3,084	1,644	3,982	2,156	4,112	2,192	5,309
88	1,470	2,803	1,494	3,620	1,960	3,737	1,992	4,826
96	1,347	2,570	1,370	3,318	1,796	3,426	1,826	4,424
104	1,244	2,372	1,264	3,063	1,658	3,162	1,685	4,084
112	1,155	2,203	1,174	2,844	1,540	2,937	1,565	3,792
120	1,078	2,056	1,096	2,655	1,437	2,741	1,461	3,540

**Table 2-39: Out-of-Plane Bending Moment and Shear Capacity for Reinforced Masonry**

Nominal Thickness = 12 in.  
 Bar Size = No. 9  
 Reinforcement = Grade 60  
 Effective Depth = 5.813 in.

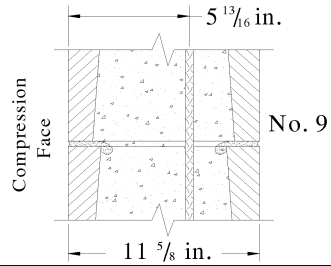
Note: When steel spacing exceeds 6 times the wall thickness or 72 inches, the portion of masonry spanning between bars shall be designed as unreinforced.



$f_m$ (psi) =	Load Combinations Not Including Wind or Seismic				Load Combinations Including Wind or Seismic			
	1,500		2,500		1,500		2,500	
	$M_R$ (ft-lb/ft)	$V_R$ (lb/ft)	$M_R$ (ft-lb/ft)	$V_R$ (lb/ft)	$M_R$ (ft-lb/ft)	$V_R$ (lb/ft)	$M_R$ (ft-lb/ft)	$V_R$ (lb/ft)
8	4,076	2,701	6,026	3,487	5,434	3,601	8,034	4,649
16	3,444	2,701	4,940	3,487	4,592	3,601	6,586	4,649
24	3,062	2,701	4,322	3,487	4,082	3,601	5,762	4,649
32	2,795	2,701	3,906	3,487	3,726	3,601	5,208	4,649
40	2,593	2,701	3,159	3,487	3,457	3,601	4,212	4,649
48	2,433	2,701	2,653	3,487	3,244	3,601	3,537	4,649
56	2,239	2,701	2,287	3,487	2,985	3,601	3,049	4,649
64	1,971	2,701	2,011	3,487	2,628	3,601	2,681	4,649
72	1,761	2,701	1,795	3,487	2,348	3,601	2,393	4,649
80	1,584	2,430	1,615	3,138	2,112	3,240	2,153	4,184
88	1,440	2,209	1,468	2,853	1,920	2,945	1,957	3,804
96	1,320	2,025	1,346	2,615	1,760	2,700	1,794	3,486
104	1,219	1,869	1,242	2,414	1,625	2,492	1,656	3,218
112	1,132	1,736	1,153	2,241	1,509	2,314	1,537	2,988
120	1,056	1,620	1,077	2,092	1,408	2,160	1,436	2,789

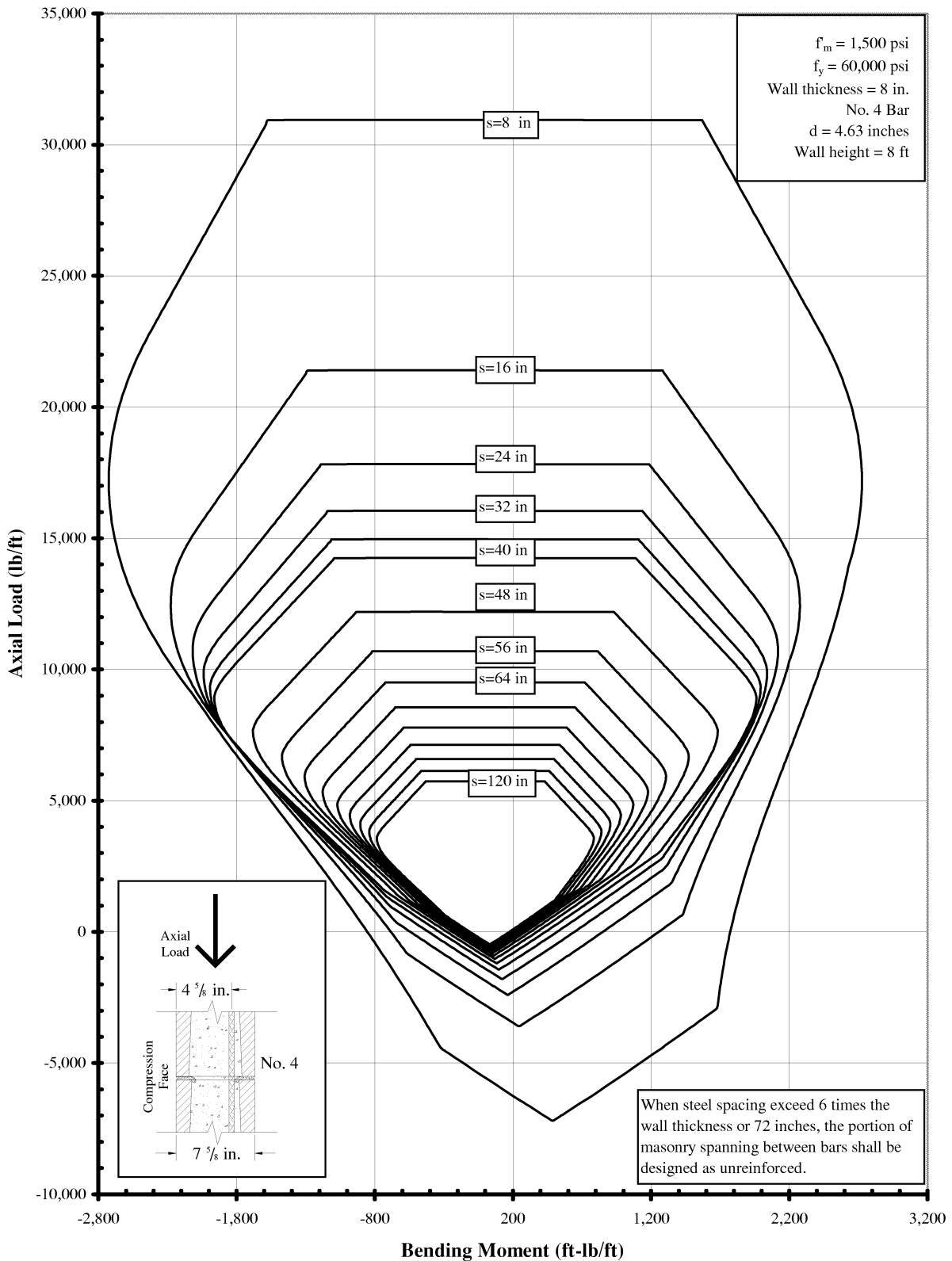
Nominal Thickness = 12 in.  
 Bar Size = No. 9  
 Reinforcement = Grade 60  
 Effective Depth = 7.375 in.

Note: When steel spacing exceeds 6 times the wall thickness or 72 inches, the portion of masonry spanning between bars shall be designed as unreinforced.

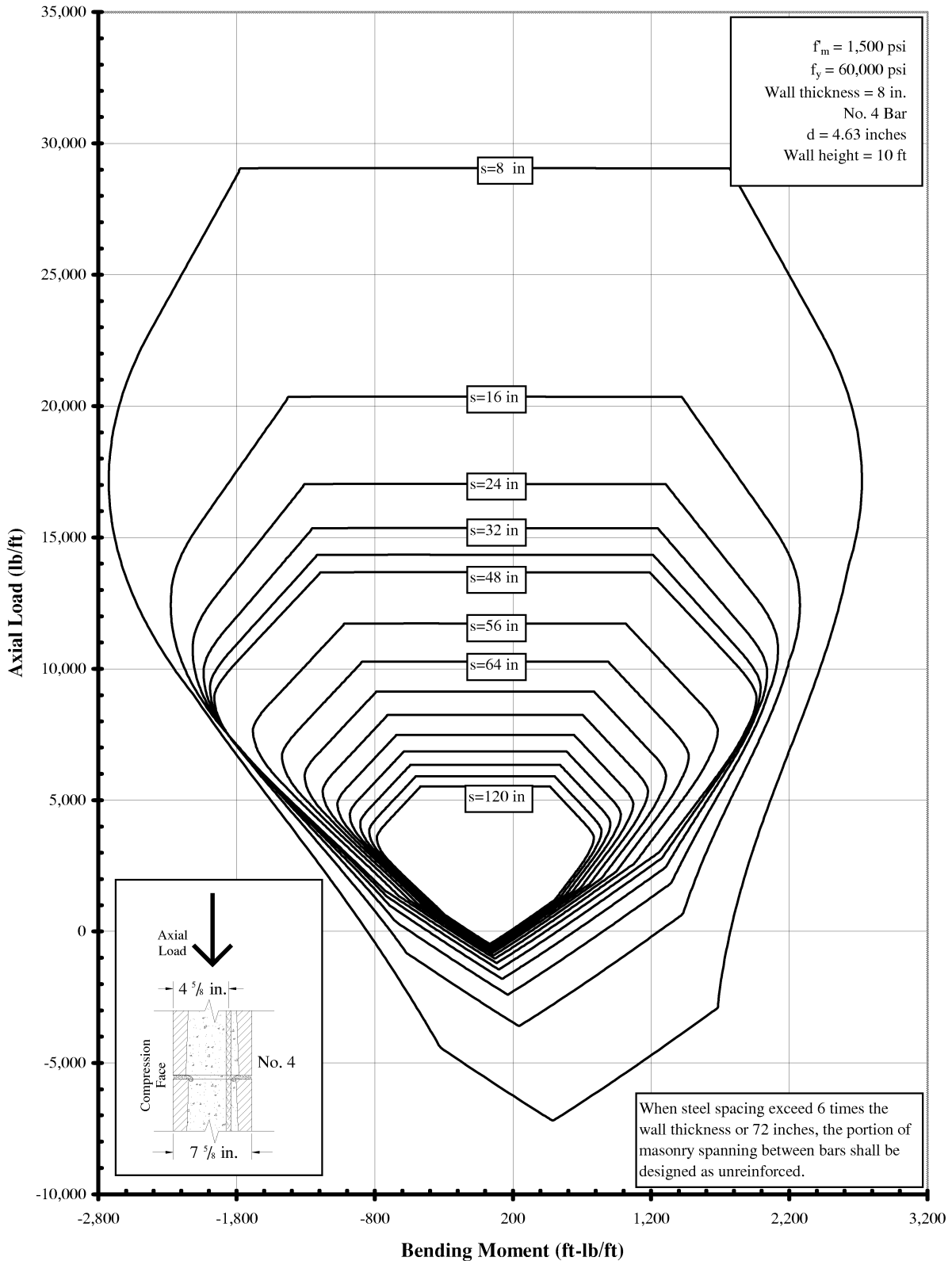


$f_m$ (psi) =	Load Combinations Not Including Wind or Seismic				Load Combinations Including Wind or Seismic			
	1,500		2,500		1,500		2,500	
	$M_R$ (ft-lb/ft)	$V_R$ (lb/ft)	$M_R$ (ft-lb/ft)	$V_R$ (lb/ft)	$M_R$ (ft-lb/ft)	$V_R$ (lb/ft)	$M_R$ (ft-lb/ft)	$V_R$ (lb/ft)
8	6,224	3,427	9,102	4,425	8,298	4,569	12,136	5,900
16	5,184	3,427	7,363	4,425	6,912	4,569	9,817	5,900
24	4,573	3,427	6,401	4,425	6,097	4,569	8,534	5,900
32	4,154	3,427	5,014	4,425	5,538	4,569	6,685	5,900
40	3,840	3,427	4,048	4,425	5,120	4,569	5,397	5,900
48	3,327	3,427	3,397	4,425	4,436	4,569	4,529	5,900
56	2,871	3,427	2,928	4,425	3,828	4,569	3,904	5,900
64	2,526	3,427	2,573	4,425	3,368	4,569	3,430	5,900
72	2,256	3,427	2,296	4,425	3,008	4,569	3,061	5,900
80	2,030	3,084	2,066	3,982	2,706	4,112	2,754	5,309
88	1,845	2,803	1,878	3,620	2,460	3,737	2,504	4,826
96	1,692	2,570	1,722	3,318	2,256	3,426	2,296	4,424
104	1,561	2,372	1,589	3,063	2,081	3,162	2,118	4,084
112	1,450	2,203	1,476	2,844	1,933	2,937	1,968	3,792
120	1,353	2,056	1,377	2,655	1,804	2,741	1,836	3,540

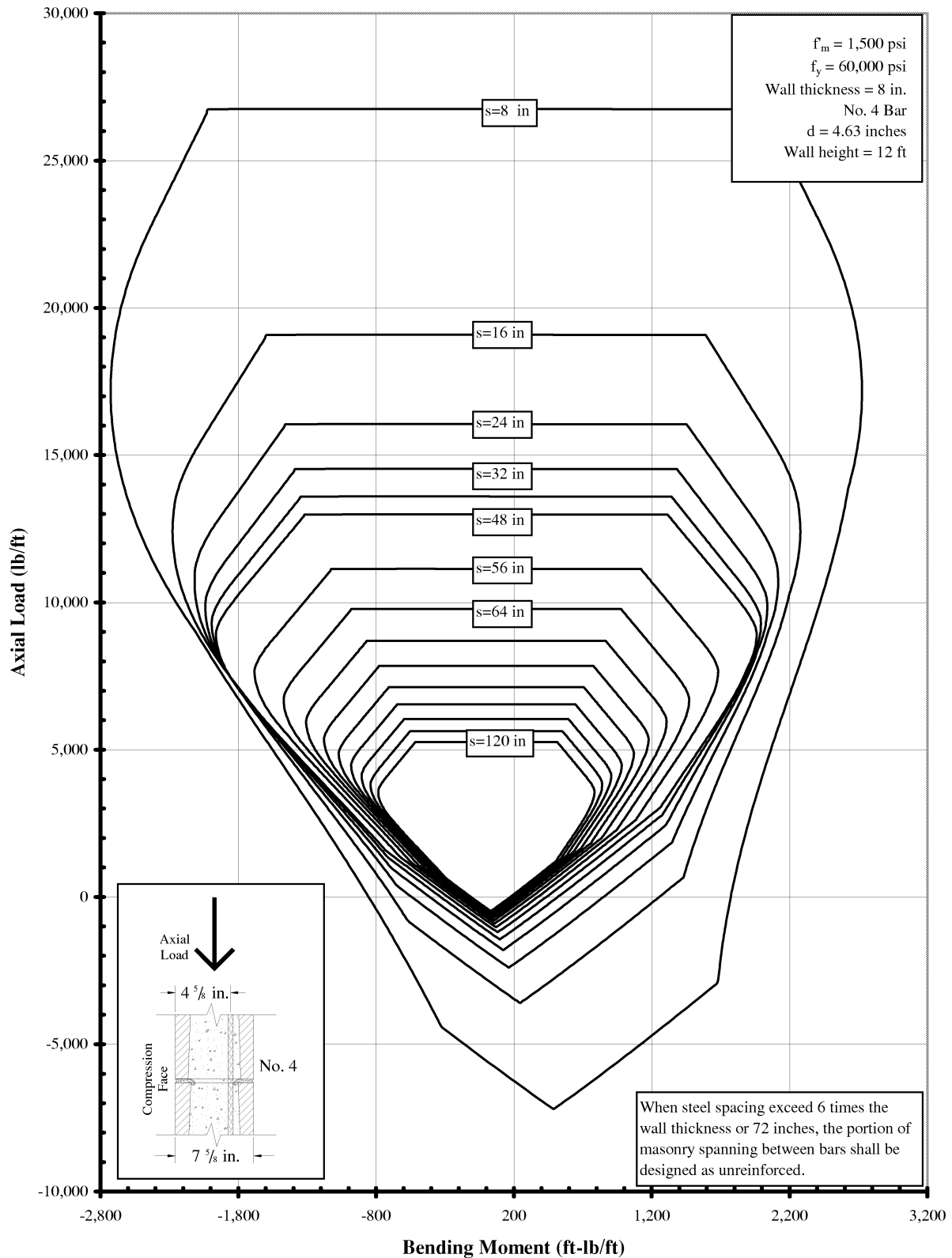
**Chart 2-1: Out-of-Plane Bending Moment and Axial Capacity Interaction Diagram for Reinforced Masonry Spanning Vertically**



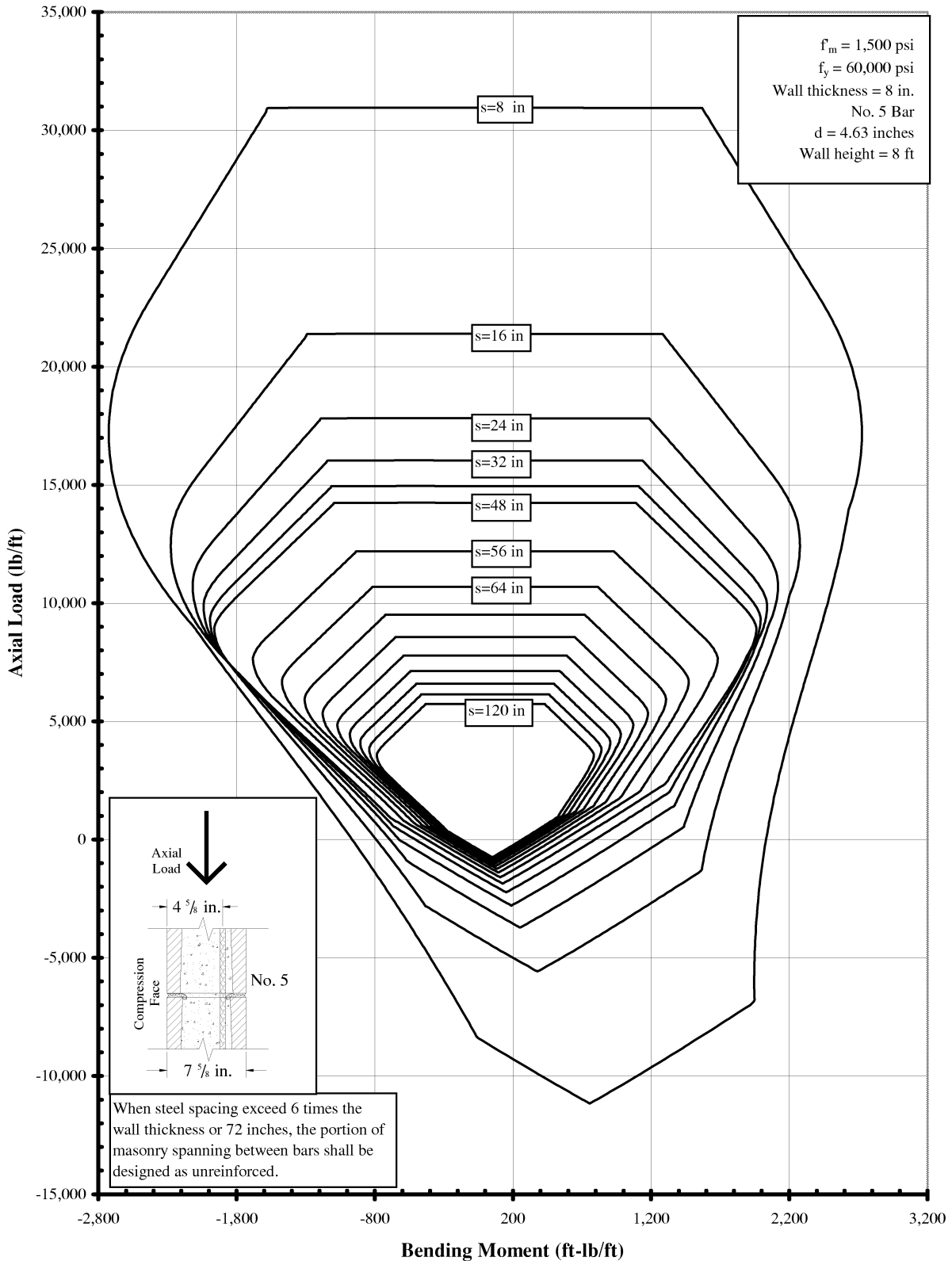
**Chart 2-2: Out-of-Plane Bending Moment and Axial Capacity Interaction Diagram for Reinforced Masonry Spanning Vertically**



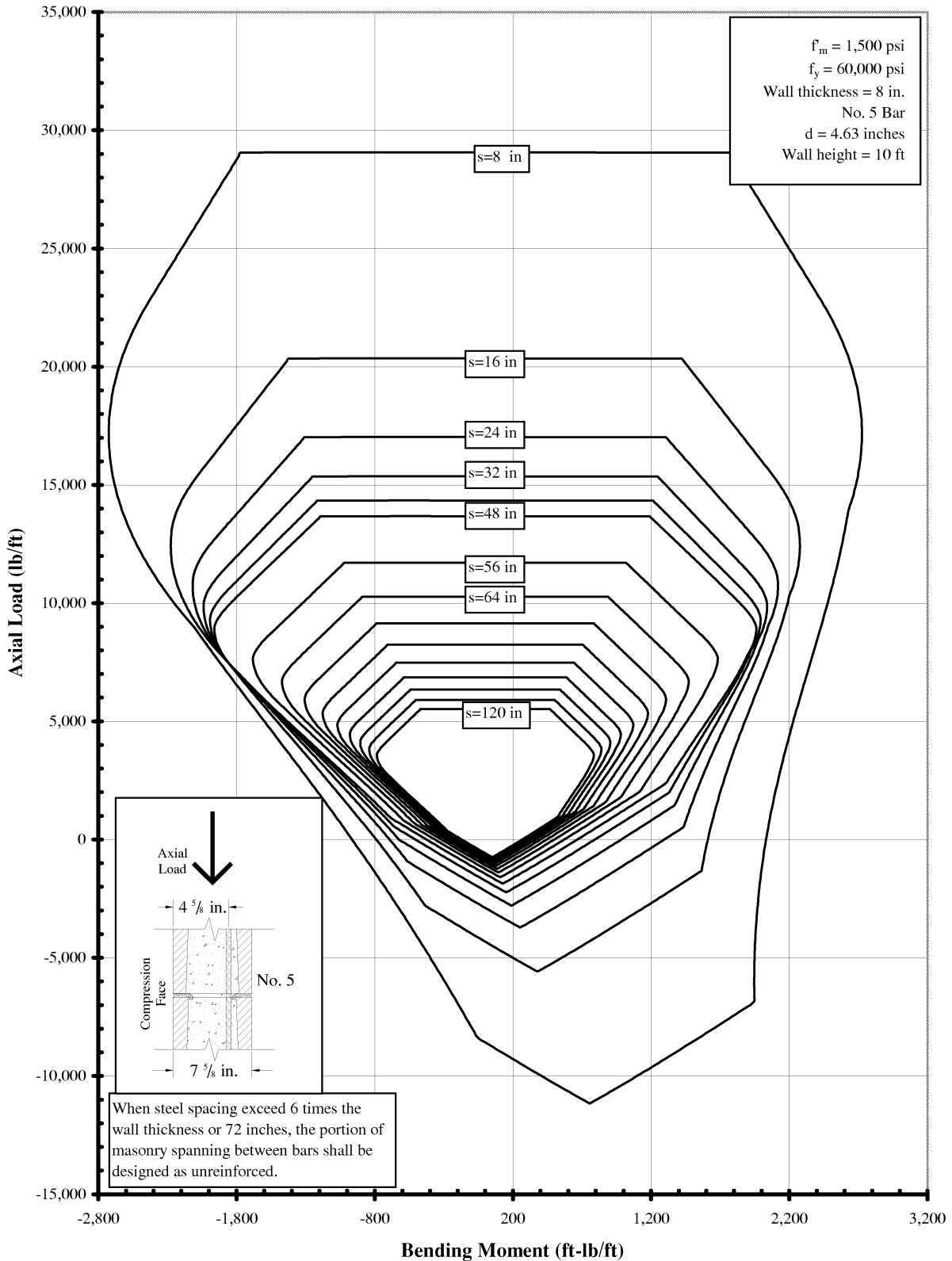
**Chart 2-3: Out-of-Plane Bending Moment and Axial Capacity Interaction Diagram for Reinforced Masonry Spanning Vertically**



**Chart 2-4: Out-of-Plane Bending Moment and Axial Capacity Interaction Diagram for Reinforced Masonry Spanning Vertically**

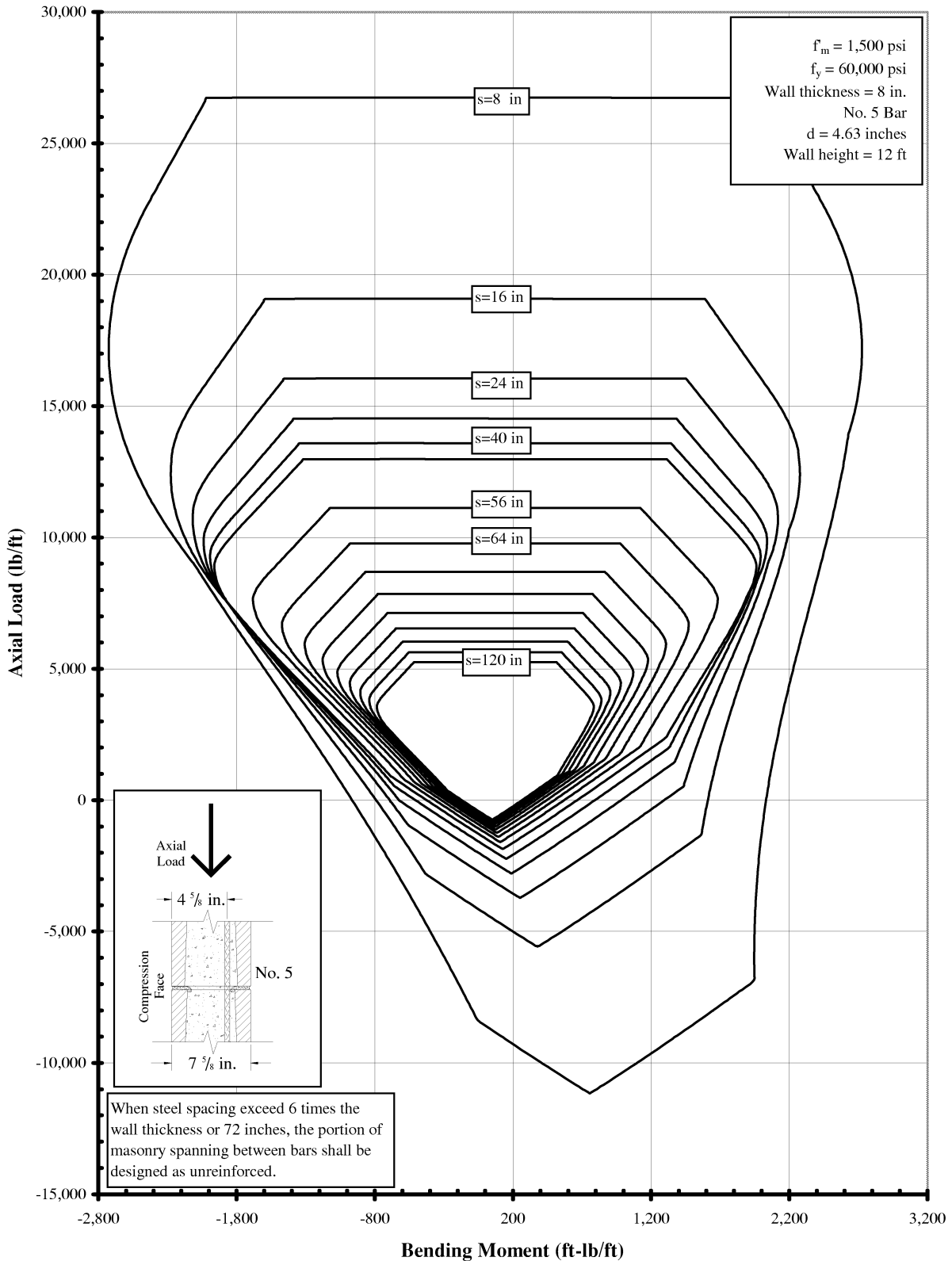


**Chart 2-5: Out-of-Plane Bending Moment and Axial Capacity Interaction Diagram for Reinforced Masonry Spanning Vertically**

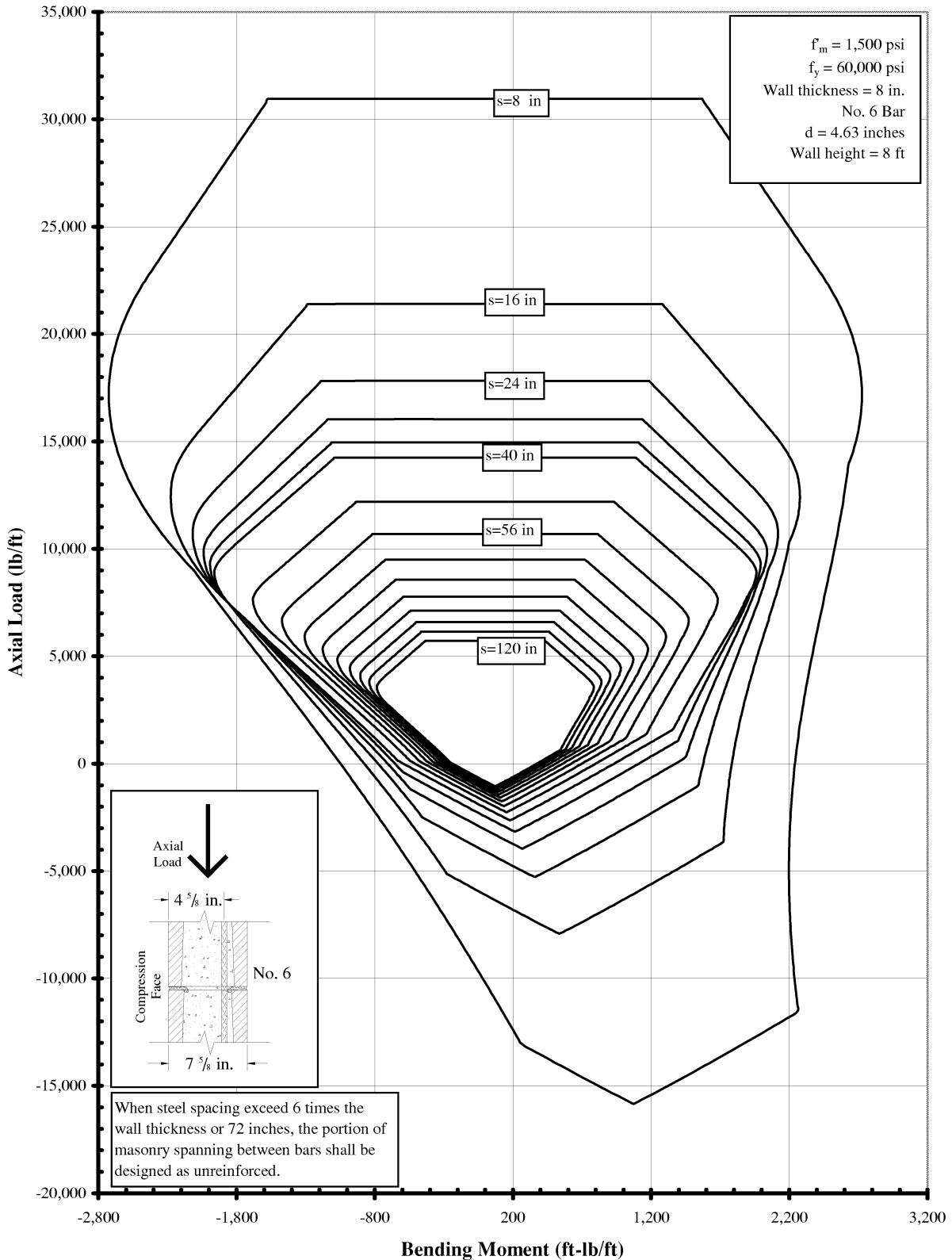




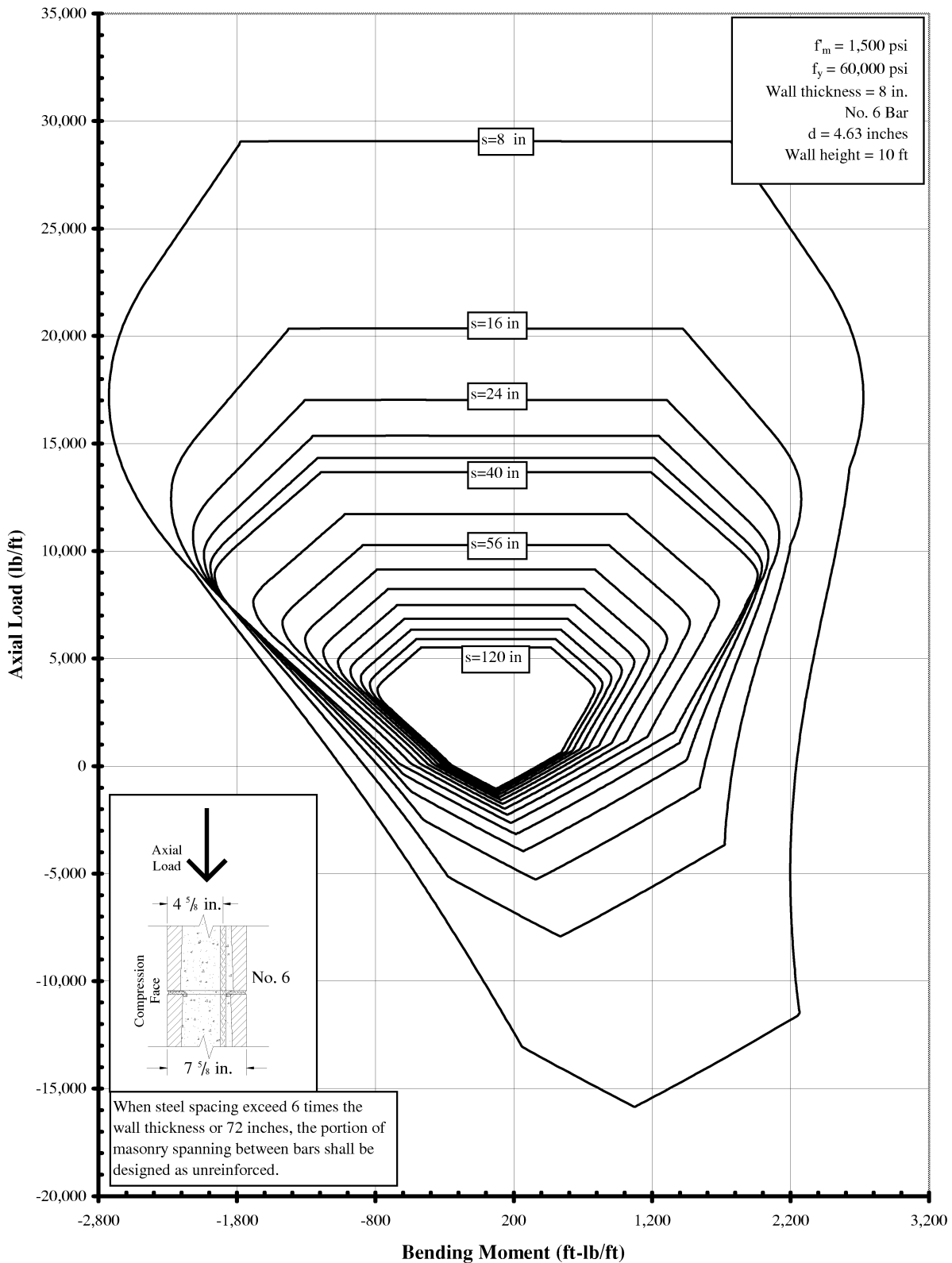
**Chart 2-6: Out-of-Plane Bending Moment and Axial Capacity Interaction Diagram for Reinforced Masonry Spanning Vertically**



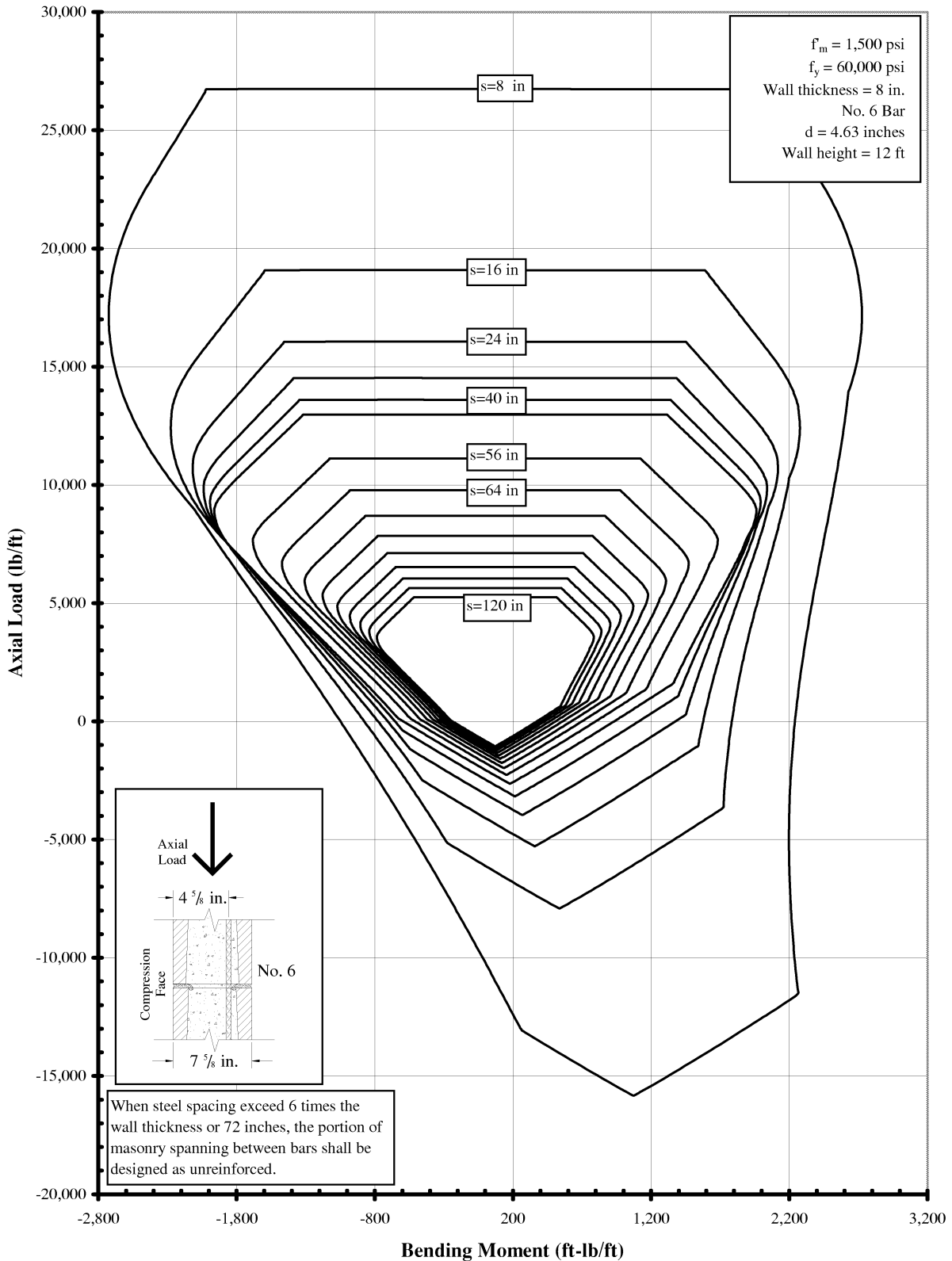
**Chart 2-7: Out-of-Plane Bending Moment and Axial Capacity Interaction Diagram for Reinforced Masonry Spanning Vertically**



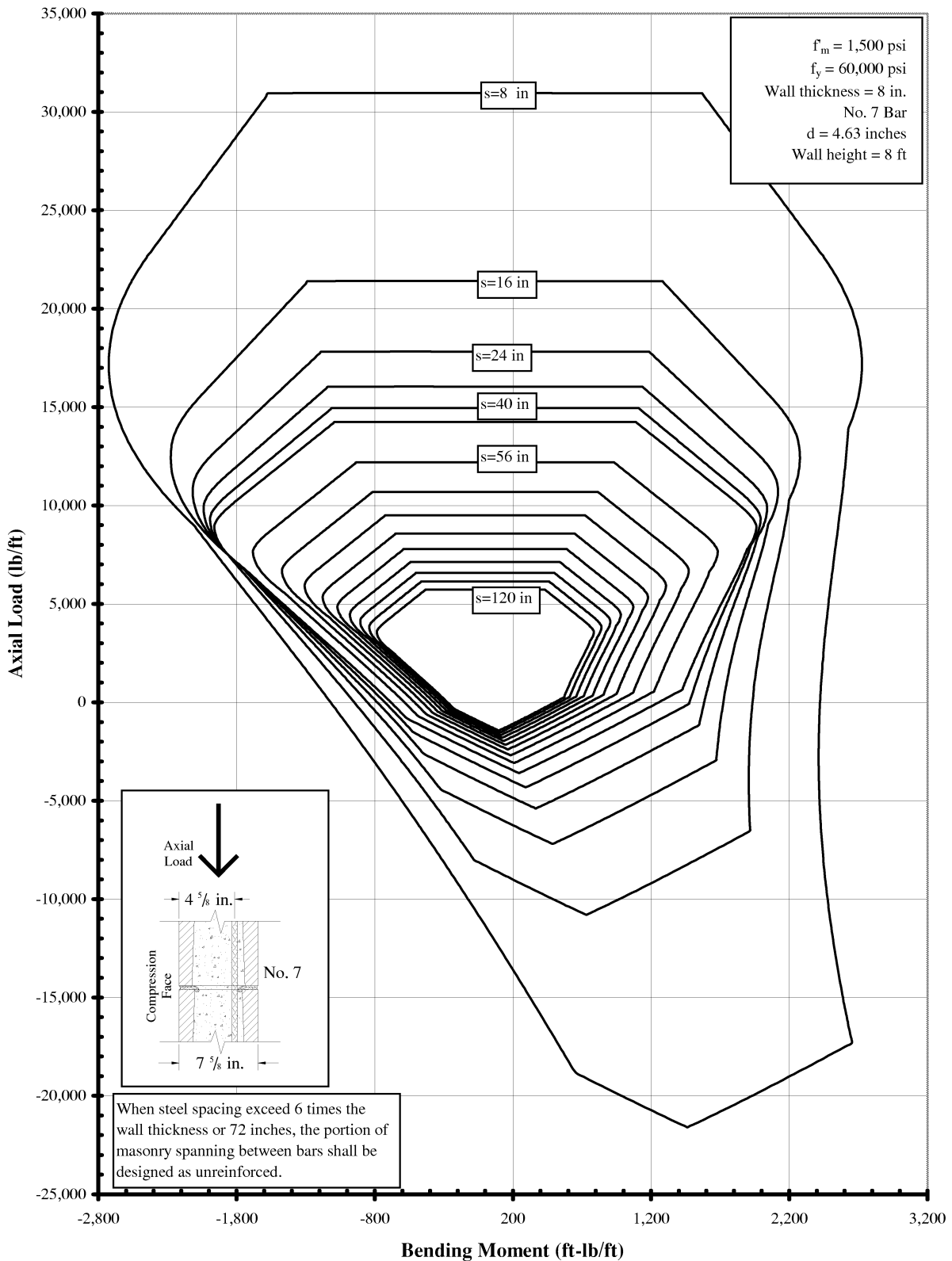
**Chart 2-8: Out-of-Plane Bending Moment and Axial Capacity Interaction Diagram for Reinforced Masonry Spanning Vertically**



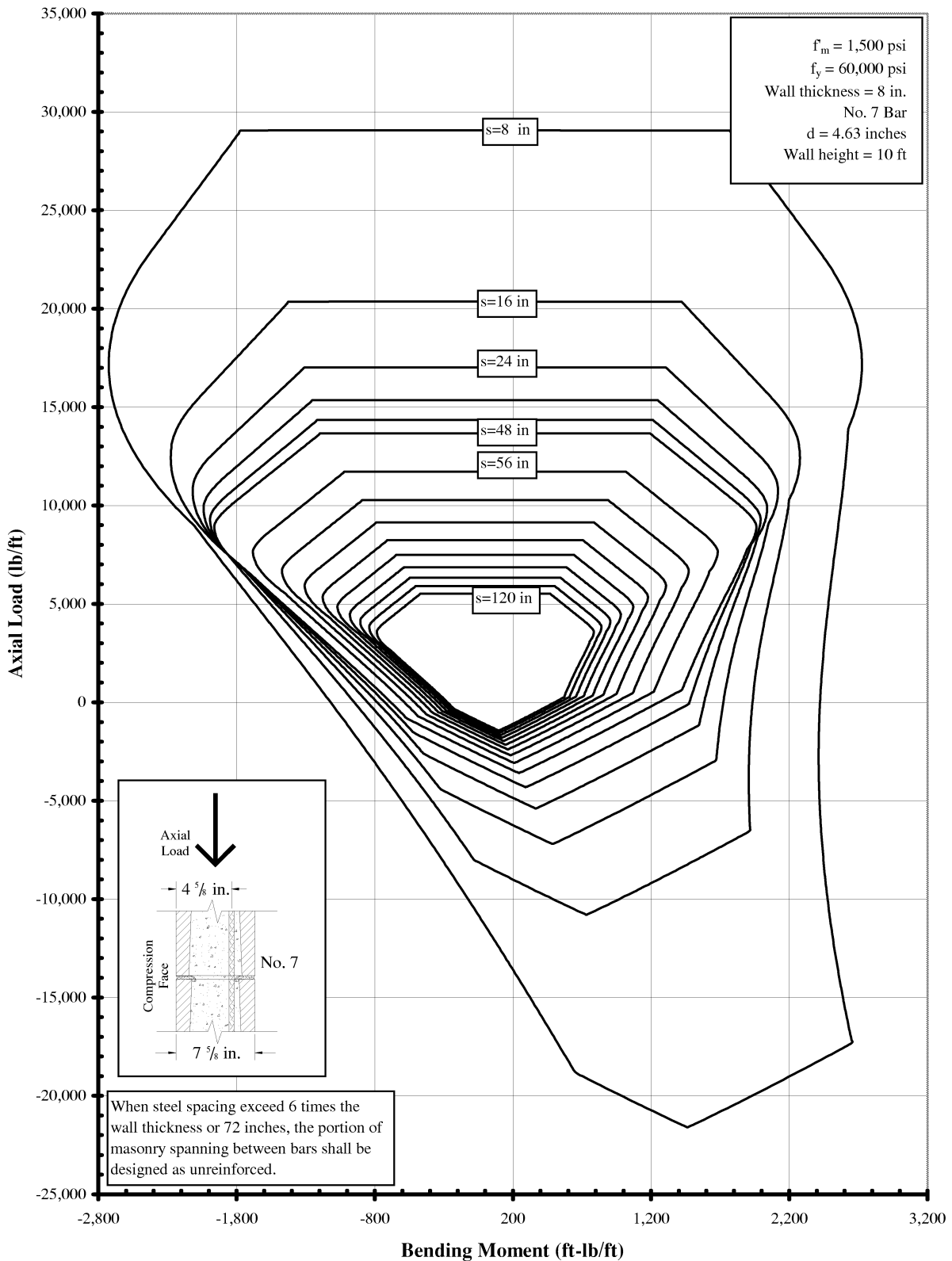
**Chart 2-9: Out-of-Plane Bending Moment and Axial Capacity Interaction Diagram for Reinforced Masonry Spanning Vertically**



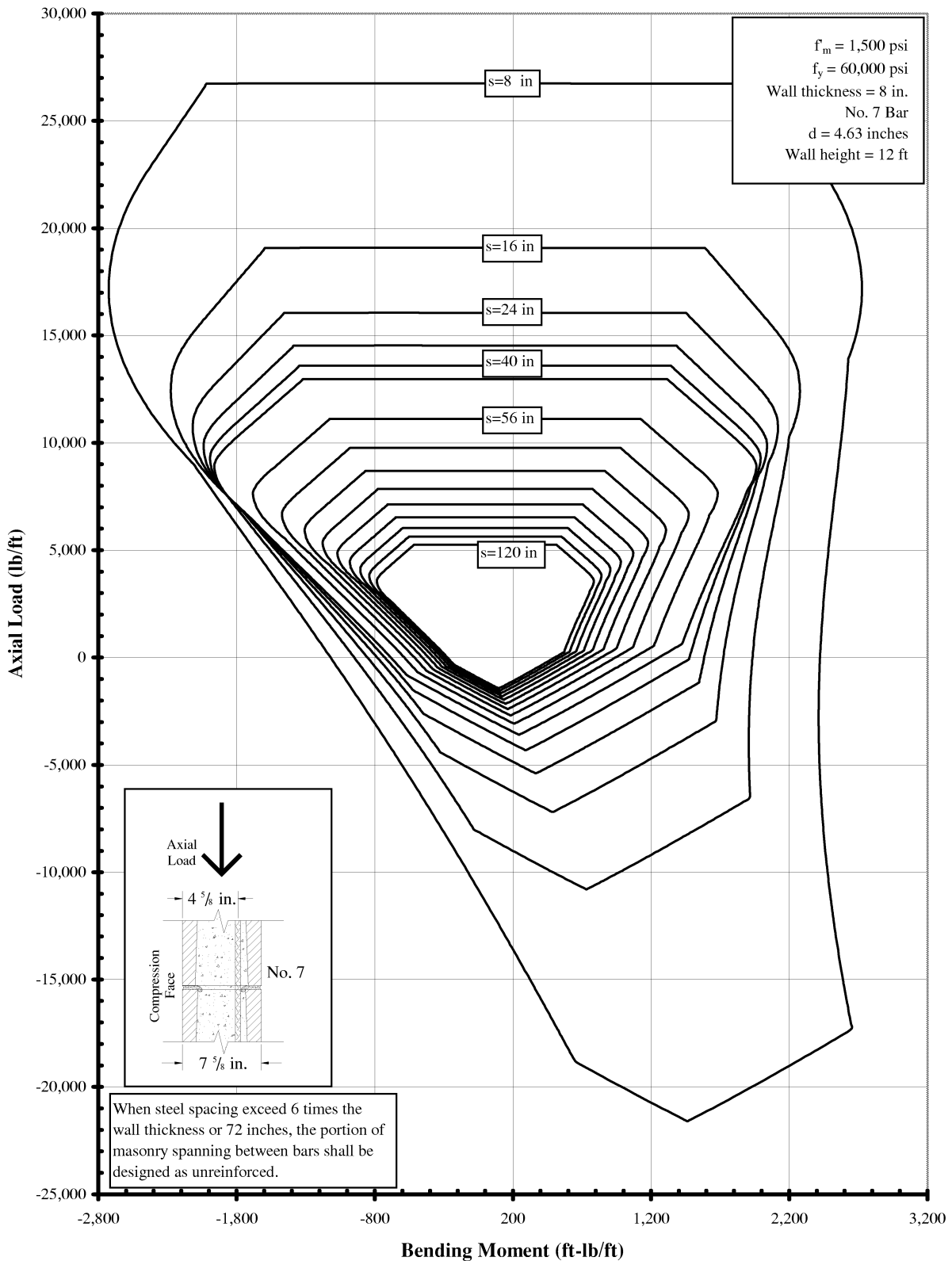
**Chart 2-10: Out-of-Plane Bending Moment and Axial Capacity Interaction Diagram for Reinforced Masonry Spanning Vertically**



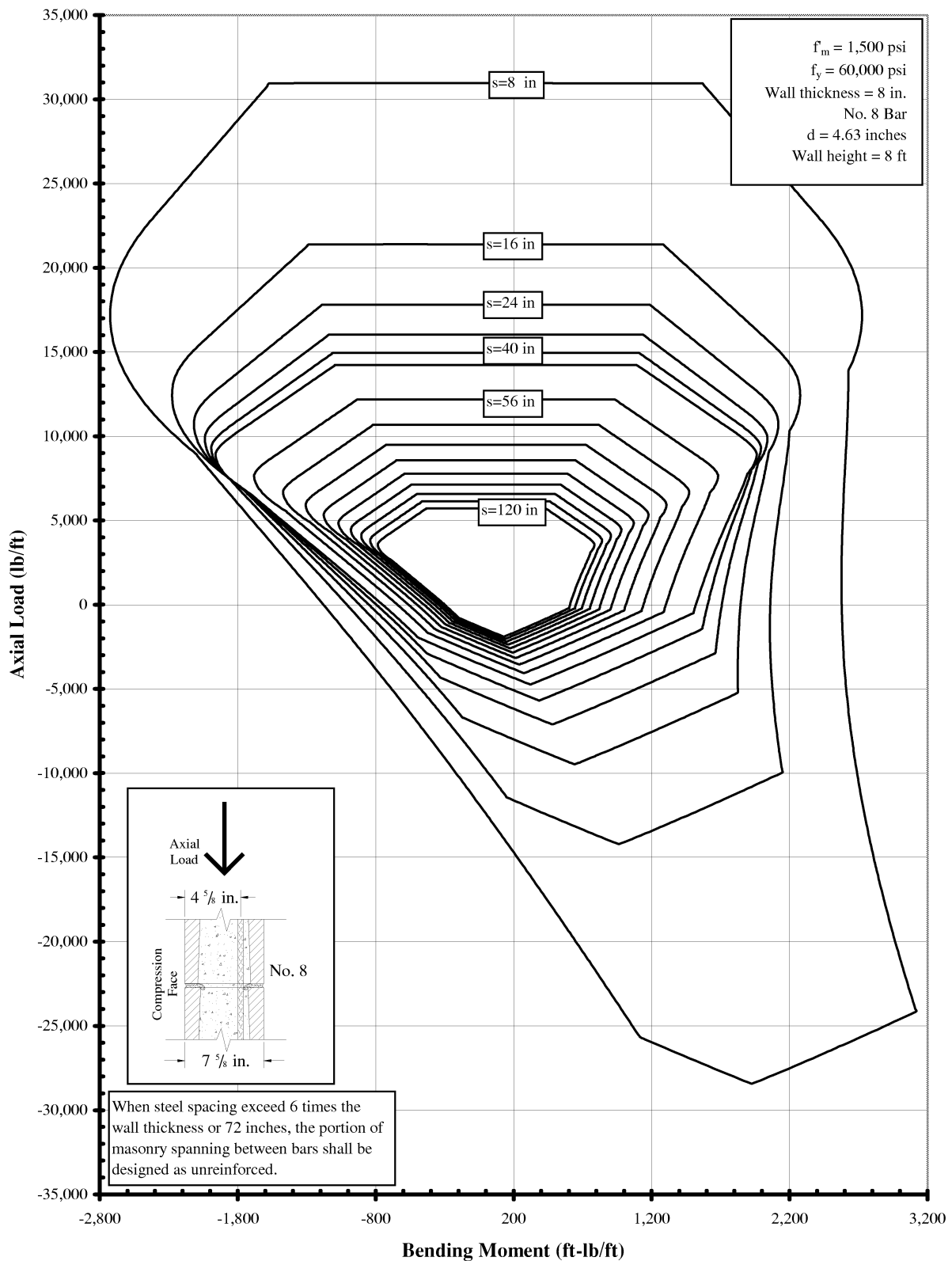
**Chart 2-11: Out-of-Plane Bending Moment and Axial Capacity Interaction Diagram for Reinforced Masonry Spanning Vertically**



**Chart 2-12: Out-of-Plane Bending Moment and Axial Capacity Interaction Diagram for Reinforced Masonry Spanning Vertically**

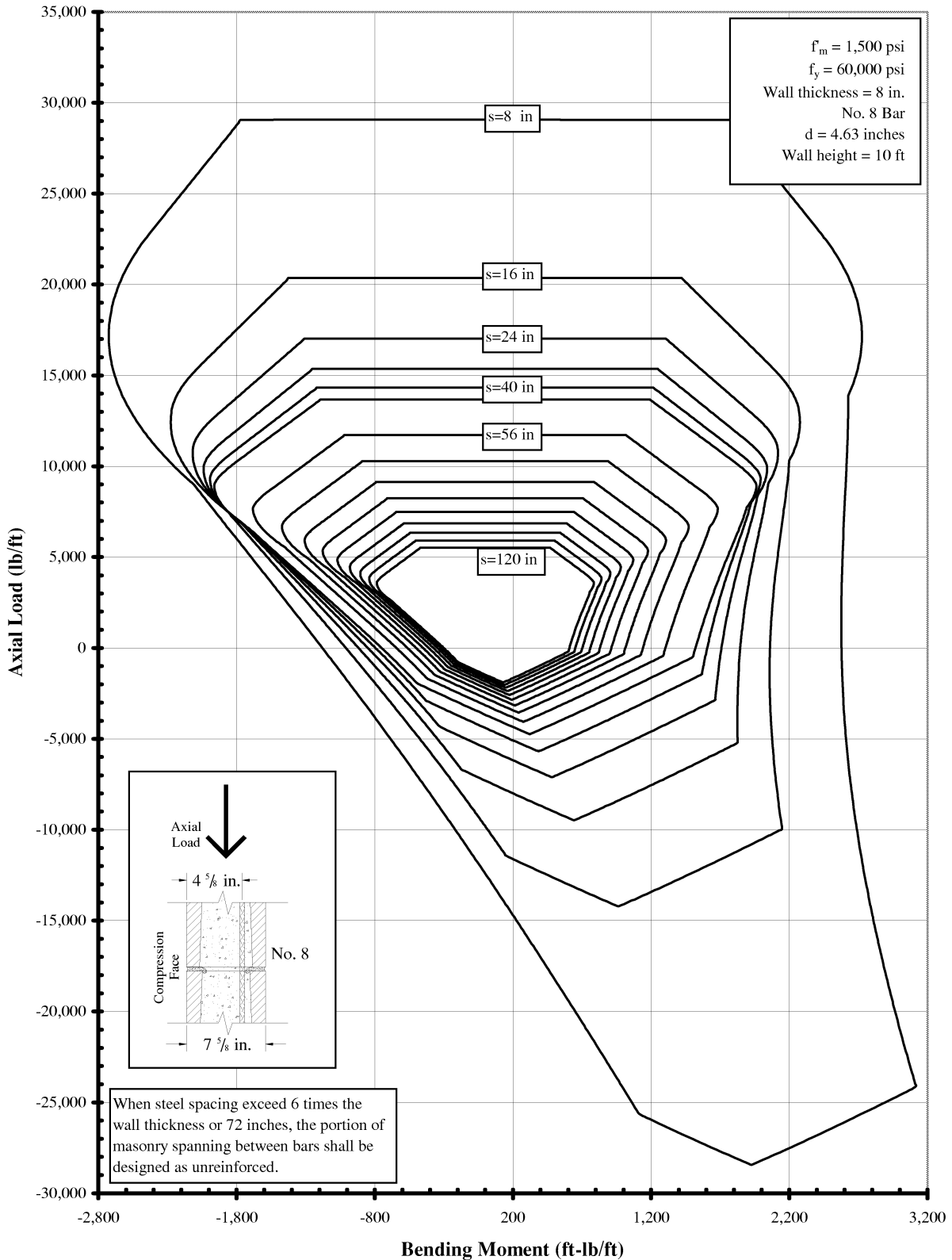


**Chart 2-13: Out-of-Plane Bending Moment and Axial Capacity Interaction Diagram for Reinforced Masonry Spanning Vertically**

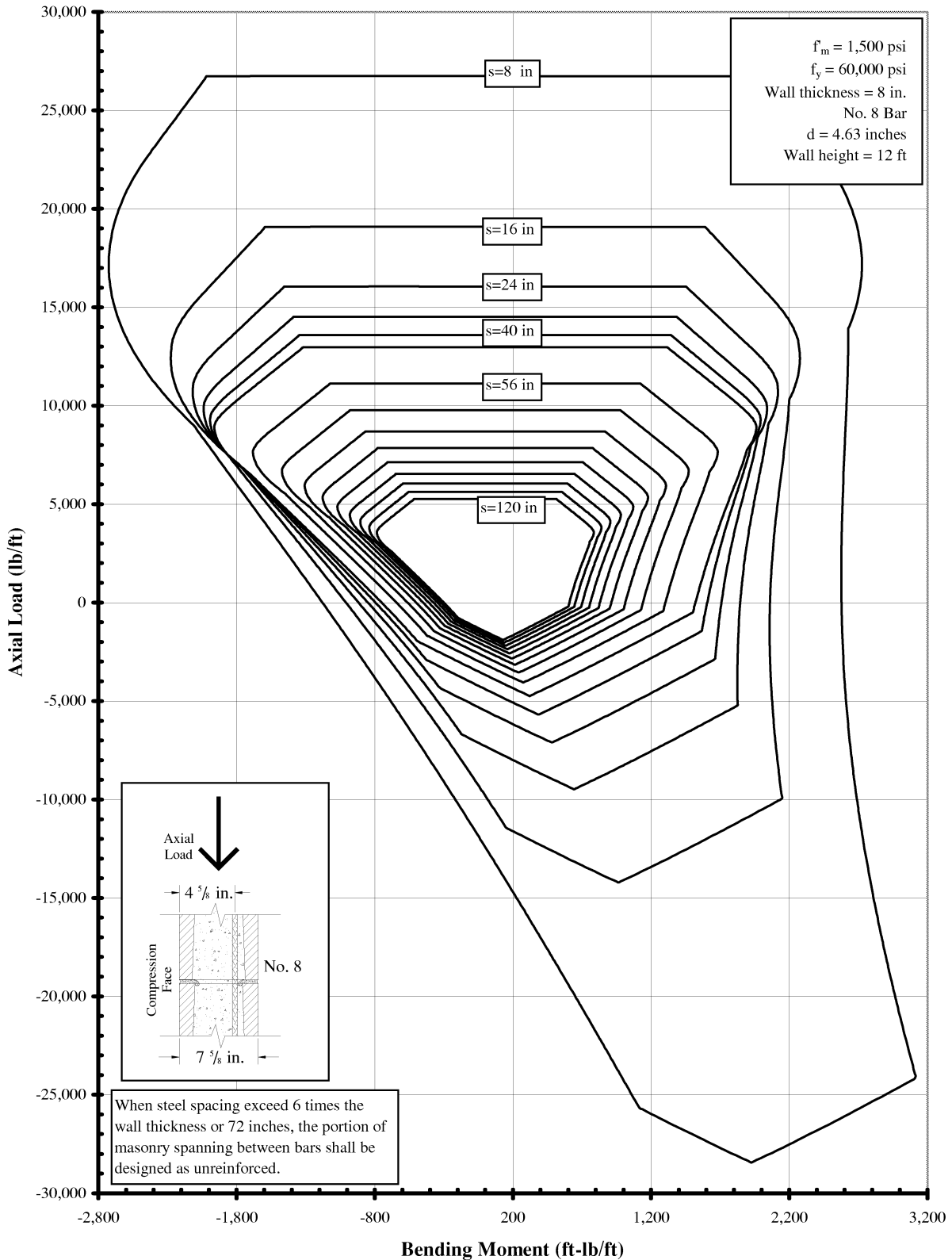




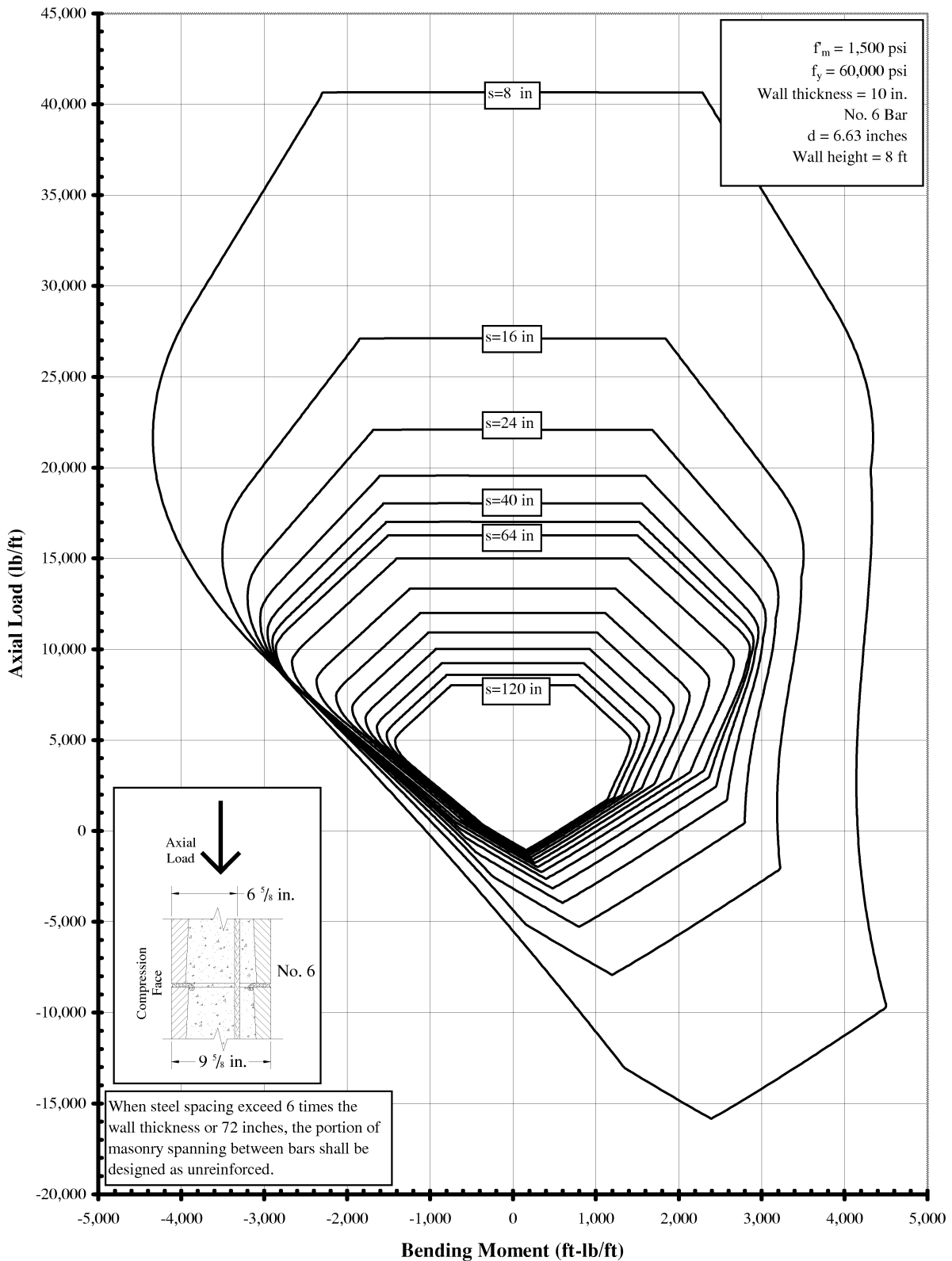
**Chart 2-14: Out-of-Plane Bending Moment and Axial Capacity Interaction Diagram for Reinforced Masonry Spanning Vertically**



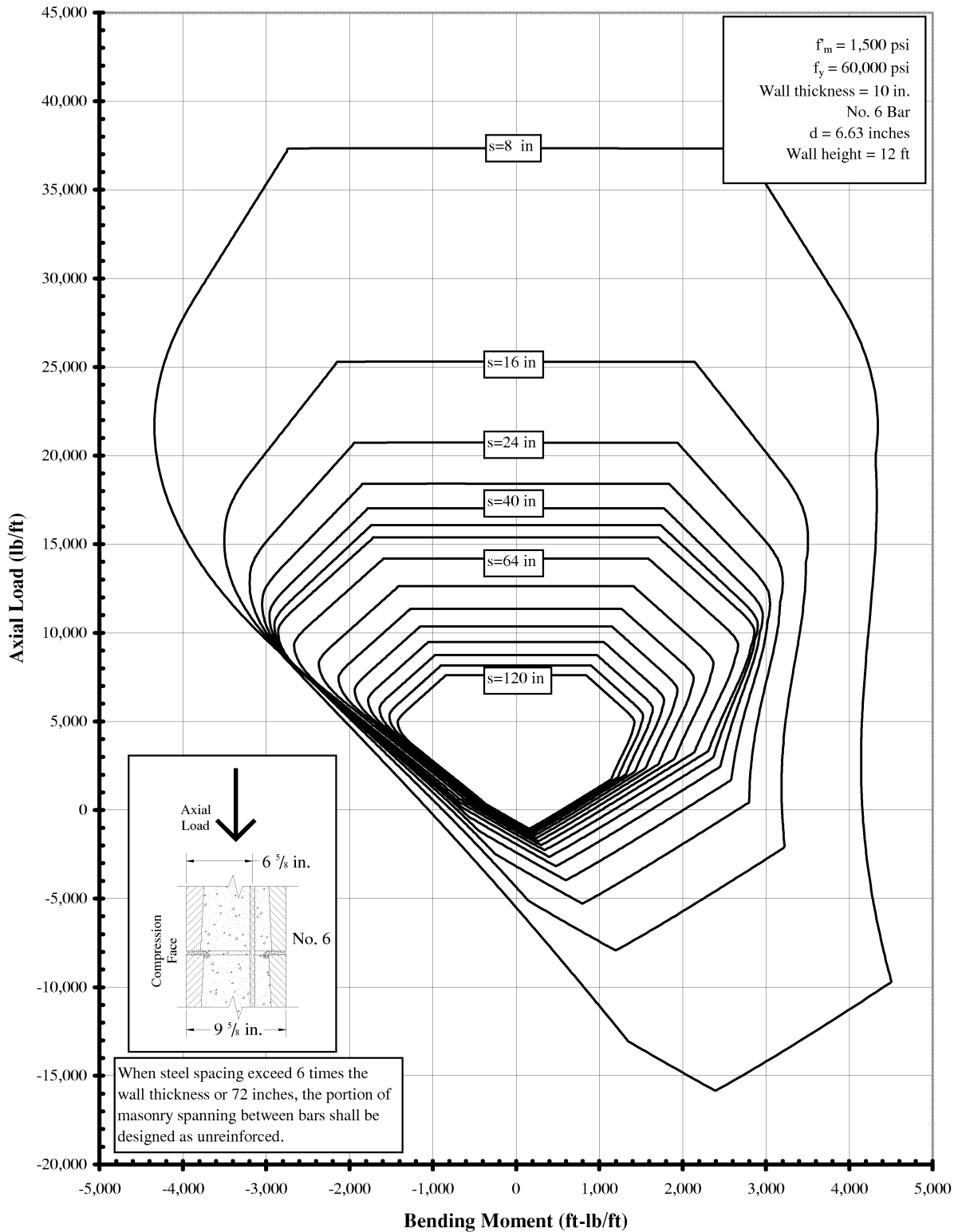
**Chart 2-15: Out-of-Plane Bending Moment and Axial Capacity Interaction Diagram for Reinforced Masonry Spanning Vertically**



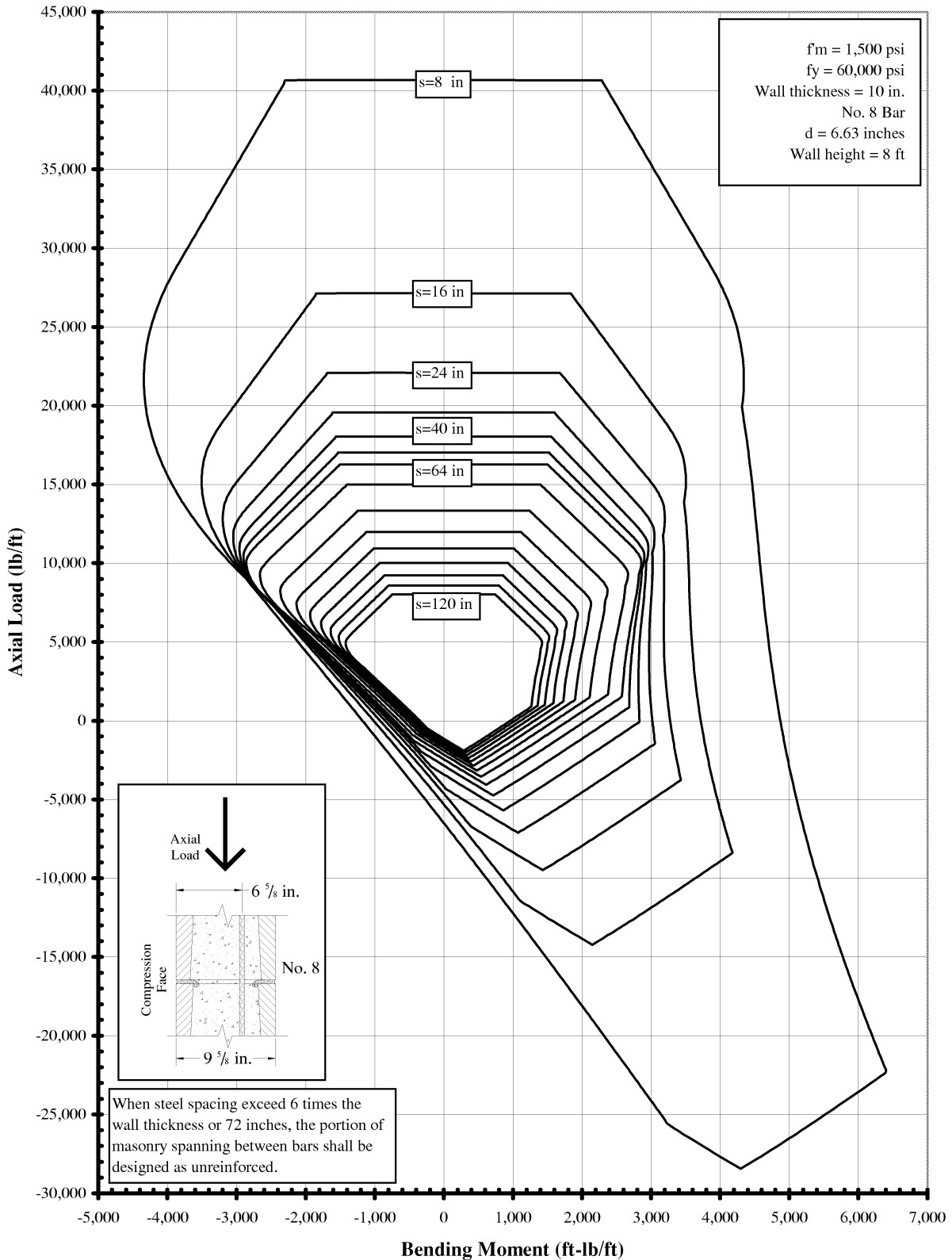
**Chart 2-16: Out-of-Plane Bending Moment and Axial Capacity Interaction Diagram for Reinforced Masonry Spanning Vertically**



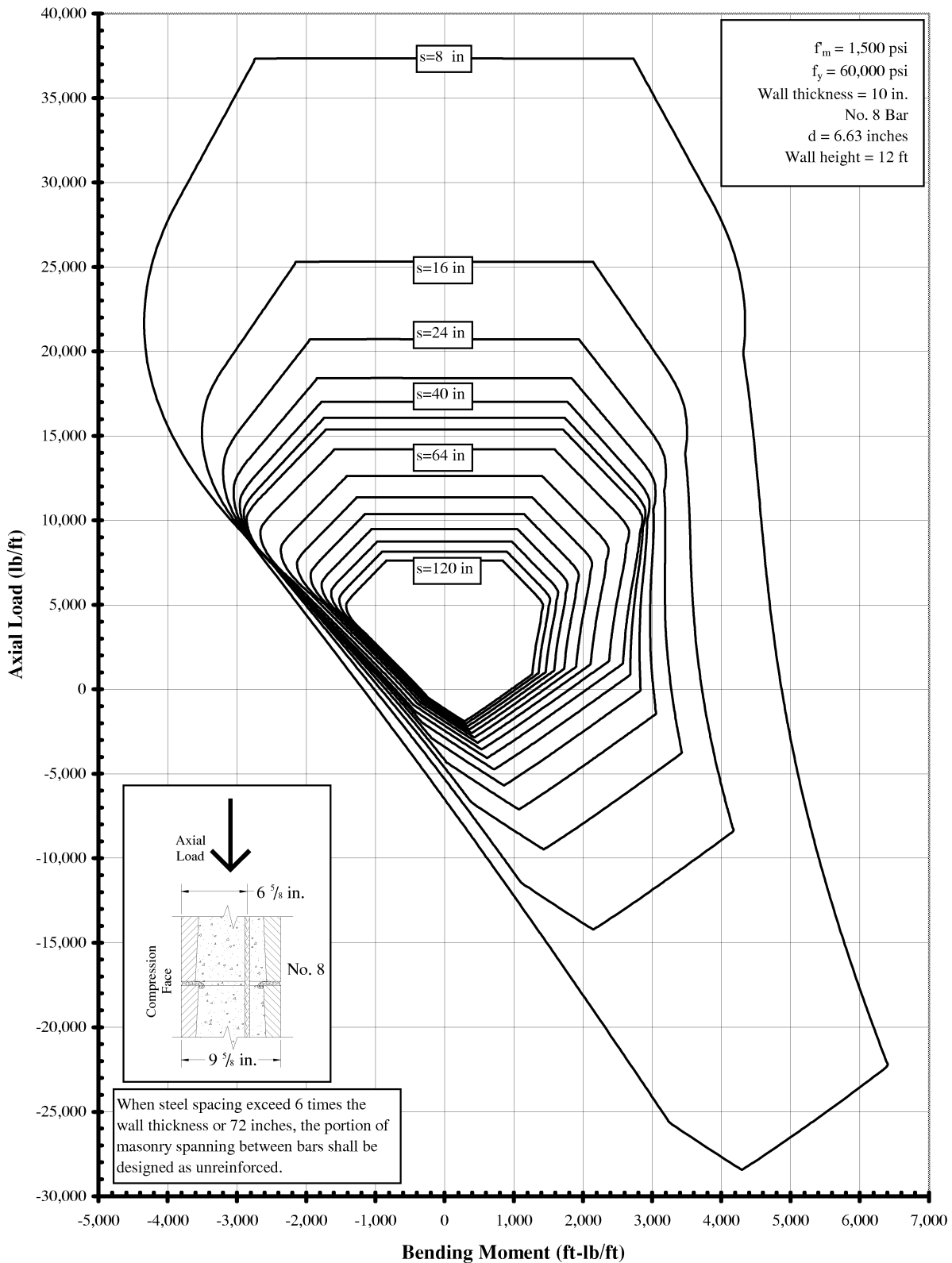
**Chart 2-17: Out-of-Plane Bending Moment and Axial Capacity Interaction Diagram for Reinforced Masonry Spanning Vertically**



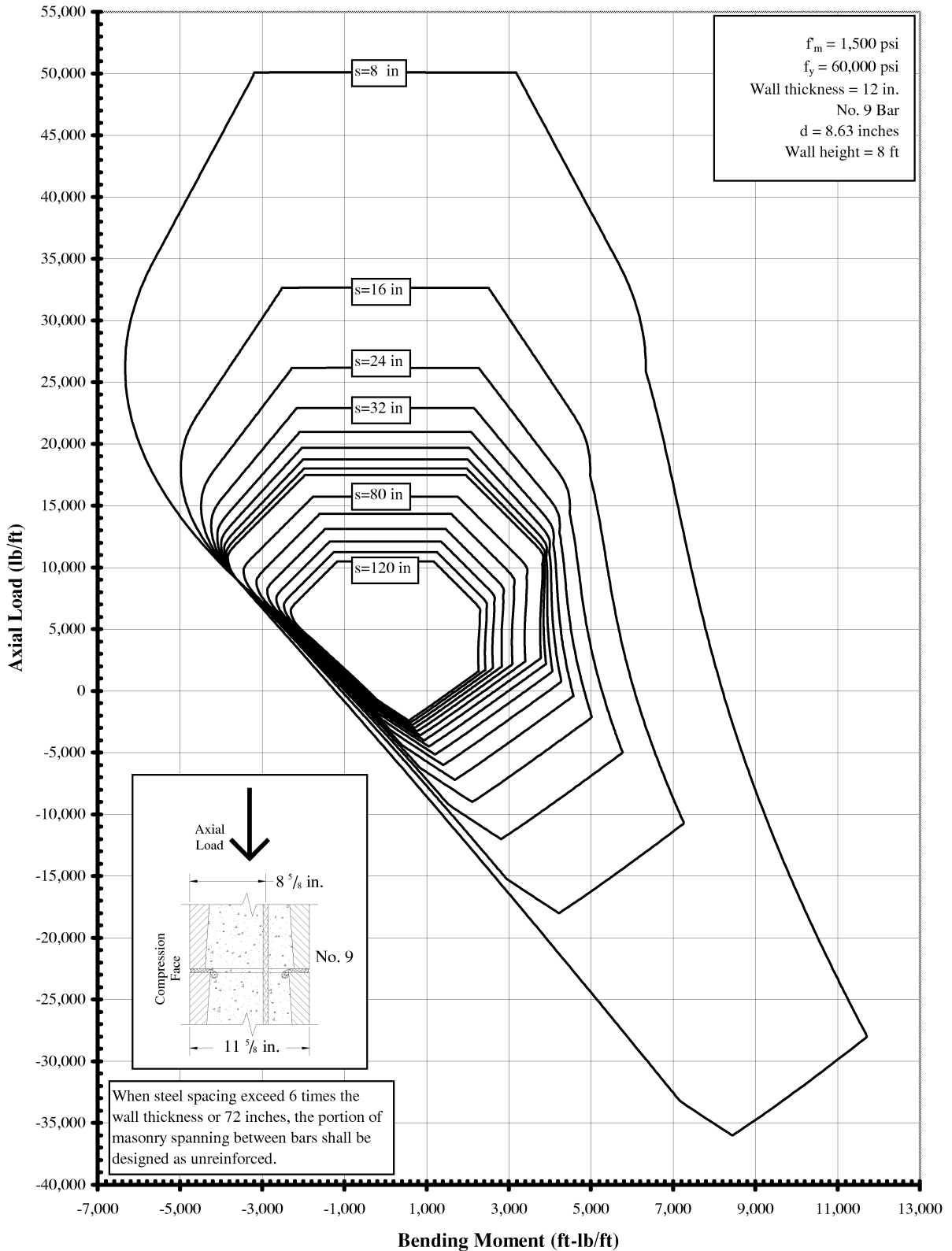
**Chart 2-18: Out-of-Plane Bending Moment and Axial Capacity Interaction Diagram for Reinforced Masonry Spanning Vertically**



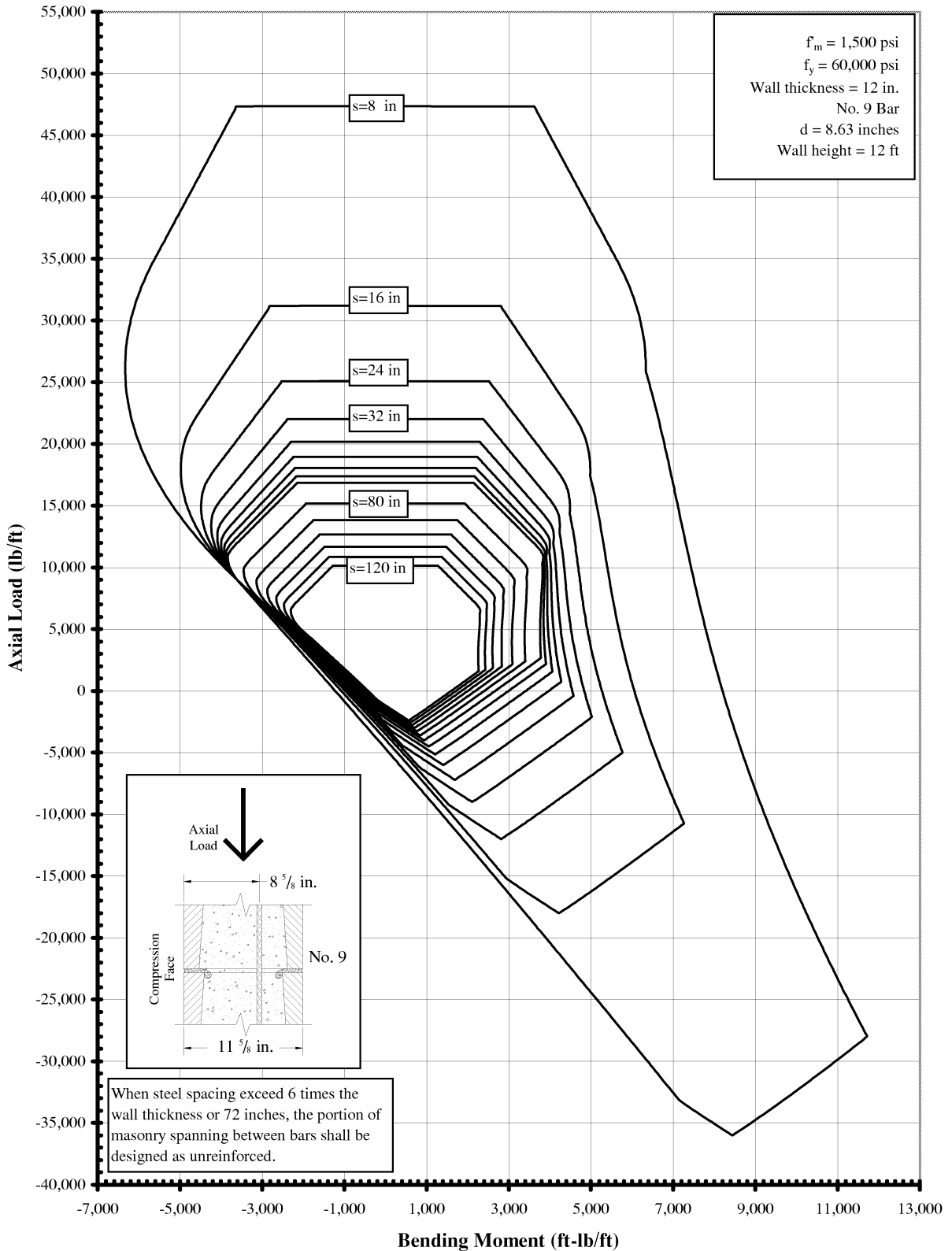
**Chart 2-19: Out-of-Plane Bending Moment and Axial Capacity Interaction Diagram for Reinforced Masonry Spanning Vertically**



**Chart 2-20: Out-of-Plane Bending Moment and Axial Capacity Interaction Diagram for Reinforced Masonry Spanning Vertically**

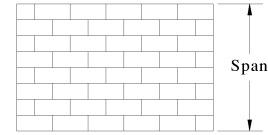


**Chart 2-21: Out-of-Plane Bending Moment and Axial Capacity Interaction Diagram for Reinforced Masonry Spanning Vertically**





**Table 2-40: Out-of-Plane Bending Moment and Shear Capacity for Unreinforced Masonry Spanning Perpendicular to Bed Joints**  
Type M or S Mortar in Running Bond



$f'_m = 1,500$ psi Mortar Type		Load Combinations Not Including Wind or Seismic <sup>1</sup>				Load Combinations Including Wind or Seismic <sup>1,2</sup>			
		Portland Cement/Lime or Mortar Cement		Air-Entrained Portland Cement/Lime or Masonry Cement		Portland Cement/Lime or Mortar Cement		Air-Entrained Portland Cement/Lime or Masonry Cement	
Wall Thickness (in.)	Type of Construction	$M_R$ (ft-lb/ft) <sup>3</sup>	$V_R$ (lb/ft) <sup>4</sup>	$M_R$ (ft-lb/ft) <sup>5</sup>	$V_R$ (lb/ft) <sup>4</sup>	$M_R$ (ft-lb/ft)	$V_R$ (lb/ft)	$M_R$ (ft-lb/ft)	$V_R$ (lb/ft)
6	Solid	210	1,665	126	1,665	281	2,220	168	2,220
	Solid Grouted	358	2,700	216	2,700	478	3,600	288	3,600
	Hollow <sup>6</sup>	96	400	57	400	128	533	77	533
8	Solid	387	2,256	232	2,256	516	3,009	310	3,009
	Solid Grouted	659	3,659	397	3,659	878	4,879	529	4,879
	Hollow <sup>6</sup>	168	550	101	550	225	733	135	733
10	Solid	617	2,849	370	2,849	823	3,798	494	3,798
	Solid Grouted	1,050	4,620	633	4,620	1,400	6,160	844	6,160
	Hollow <sup>6</sup>	245	798	147	798	327	1,064	196	1,064
12	Solid	901	3,440	540	3,440	1,201	4,587	720	4,587
	Solid Grouted	1,531	5,579	923	5,579	2,042	7,439	1,231	7,439
	Hollow <sup>6</sup>	333	978	199	978	444	1,304	266	1,304

<sup>1</sup>For partially grouted masonry, allowable stresses may be linear interpolated between fully grouted and ungrouted masonry based on the amount of grouting.

<sup>2</sup>Capacities increased by a factor of 1.33 when considering load combinations that include wind or seismic.

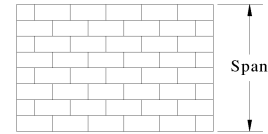
<sup>3</sup>Based on an allowable flexural tensile stress of 40 psi for solid units, 68 psi for solid grouted units, and 25 psi for hollow units.

<sup>4</sup>Based on allowable shear stress of 37 psi for hollow and solid units and 60 psi for solid grouted units.

<sup>5</sup>Based on an allowable flexural tensile stress of 24 psi for solid units, 41 psi for solid grouted units, and 15 psi for hollow units.

<sup>6</sup>Assumes face shell bedding of mortar.

**Table 2-41: Out-of-Plane Bending Moment and Shear Capacity for Unreinforced Masonry Spanning Perpendicular to Bed Joints**  
Type N Mortar in Running Bond



$f'_m = 1,500$ psi Mortar Type		Load Combinations Not Including Wind or Seismic <sup>1</sup>				Load Combinations Including Wind or Seismic <sup>1,2</sup>			
		Portland Cement/Lime or Mortar Cement		Air-Entrained Portland Cement/Lime or Masonry Cement		Portland Cement/Lime or Mortar Cement		Air-Entrained Portland Cement/Lime or Masonry Cement	
Wall Thickness (in.)	Type of Construction	$M_R$ (ft-lb/ft) <sup>3</sup>	$V_R$ (lb/ft) <sup>4</sup>	$M_R$ (ft-lb/ft) <sup>5</sup>	$V_R$ (lb/ft) <sup>4</sup>	$M_R$ (ft-lb/ft)	$V_R$ (lb/ft)	$M_R$ (ft-lb/ft)	$V_R$ (lb/ft)
6	Solid	158	1,665	79	1,665	210	2,220	105	2,220
	Solid Grouted	305	2,700	152	2,700	407	3,600	203	3,600
	Hollow <sup>6</sup>	73	400	34	400	97	533	46	533
8	Solid	290	2,256	145	2,256	387	3,009	193	3,009
	Solid Grouted	562	3,659	281	3,659	749	4,879	374	4,879
	Hollow <sup>6</sup>	128	550	60	550	171	733	81	733
10	Solid	463	2,849	231	2,849	617	3,798	308	3,798
	Solid Grouted	895	4,620	447	4,620	1,194	6,160	597	6,160
	Hollow <sup>6</sup>	186	798	88	798	248	1,064	117	1,064
12	Solid	675	3,440	337	3,440	901	4,587	450	4,587
	Solid Grouted	1,306	5,579	653	5,579	1,741	7,439	870	7,439
	Hollow <sup>6</sup>	253	978	119	978	337	1,304	159	1,304

<sup>1</sup>For partially grouted masonry, allowable stresses may be linear interpolated between fully grouted and ungrouted masonry based on the amount of grouting.

<sup>2</sup>Capacities increased by a factor of 1.33 when considering load combinations that include wind or seismic.

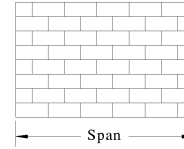
<sup>3</sup>Based on an allowable flexural tensile stress of 30 psi for solid units, 58 psi for solid grouted units, and 19 psi for hollow units.

<sup>4</sup>Based on allowable shear stress of 37 psi for hollow and solid units and 60 psi for solid grouted units.

<sup>5</sup>Based on an allowable flexural tensile stress of 15 psi for solid units, 29 psi for solid grouted units, and 9 psi for hollow units.

<sup>6</sup>Assumes face shell bedding of mortar.

**Table 2-42: Out-of-Plane Bending Moment and Shear Capacity for Unreinforced Masonry Spanning Parallel to Bed Joints**  
Type M or S Mortar in Running Bond



$f_m = 1,500$ psi		Load Combinations Not Including Wind or Seismic <sup>1</sup>				Load Combinations Including Wind or Seismic <sup>1,2</sup>			
		Portland Cement/Lime or Mortar Cement		Air-Entrained Portland Cement/Lime or Masonry Cement		Portland Cement/Lime or Mortar Cement		Air-Entrained Portland Cement/Lime or Masonry Cement	
Wall Thickness (in.)	Type of Construction	$M_R$ (ft-lb/ft) <sup>3</sup>	$V_R$ (lb/ft) <sup>4</sup>	$M_R$ (ft-lb/ft) <sup>5</sup>	$V_R$ (lb/ft) <sup>4</sup>	$M_R$ (ft-lb/ft)	$V_R$ (lb/ft)	$M_R$ (ft-lb/ft)	$V_R$ (lb/ft)
6	Solid	422	1,665	253	1,665	562	2,220	337	2,220
	Solid Grouted	422	2,700	253	2,700	562	3,600	337	3,600
	Hollow <sup>6</sup>	192	400	115	400	257	533	154	533
8	Solid	775	2,256	465	2,256	1,033	3,009	620	3,009
	Solid Grouted	775	3,659	465	3,659	1,033	4,879	620	4,879
	Hollow <sup>6</sup>	337	550	202	550	450	733	270	733
10	Solid	1,235	2,849	741	2,849	1,647	3,798	988	3,798
	Solid Grouted	1,235	4,620	741	4,620	1,647	6,160	988	6,160
	Hollow <sup>6</sup>	490	798	294	798	654	1,064	392	1,064
12	Solid	1,802	3,440	1,081	3,440	2,402	4,587	1,441	4,587
	Solid Grouted	1,802	5,579	1,081	5,579	2,402	7,439	1,441	7,439
	Hollow <sup>6</sup>	666	978	399	978	888	1,304	533	1,304

<sup>1</sup>For partially grouted masonry, allowable stresses may be linear interpolated between fully grouted and ungrouted masonry based on the amount of grouting.

<sup>2</sup>Capacities increased by a factor of 1.33 when considering load combinations that include wind or seismic.

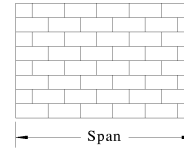
<sup>3</sup>Based on an allowable flexural tensile stress of 80 psi for solid and solid grouted units and 50 psi for hollow units.

<sup>4</sup>Based on allowable shear stress of 37 psi for hollow and solid units and 60 psi for solid grouted units.

<sup>5</sup>Based on an allowable flexural tensile stress of 48 psi for solid and solid grouted units and 30 psi for hollow units.

<sup>6</sup>Assumes face shell bedding of mortar.

**Table 2-43: Out-of-Plane Bending Moment and Shear Capacity for Unreinforced Masonry Spanning Parallel to Bed Joints**  
Type N Mortar in Running Bond



$f_m = 1,500$ psi		Load Combinations Not Including Wind or Seismic <sup>1</sup>				Load Combinations Including Wind or Seismic <sup>1,2</sup>			
		Portland Cement/Lime or Mortar Cement		Air-Entrained Portland Cement/Lime or Masonry Cement		Portland Cement/Lime or Mortar Cement		Air-Entrained Portland Cement/Lime or Masonry Cement	
Wall Thickness (in.)	Type of Construction	$M_R$ (ft-lb/ft) <sup>3</sup>	$V_R$ (lb/ft) <sup>4</sup>	$M_R$ (ft-lb/ft) <sup>5</sup>	$V_R$ (lb/ft) <sup>4</sup>	$M_R$ (ft-lb/ft)	$V_R$ (lb/ft)	$M_R$ (ft-lb/ft)	$V_R$ (lb/ft)
6	Solid	316	1,665	158	1,665	421	2,220	210	2,220
	Solid Grouted	316	2,700	158	2,700	422	3,600	211	3,600
	Hollow <sup>6</sup>	146	400	73	400	195	533	97	533
8	Solid	581	2,256	290	2,256	775	3,009	387	3,009
	Solid Grouted	581	3,659	290	3,659	775	4,879	387	4,879
	Hollow <sup>6</sup>	256	550	128	550	342	733	171	733
10	Solid	926	2,849	463	2,849	1,235	3,798	617	3,798
	Solid Grouted	926	4,620	463	4,620	1,235	6,160	617	6,160
	Hollow <sup>6</sup>	373	798	186	798	497	1,064	248	1,064
12	Solid	1,351	3,440	675	3,440	1,802	4,587	901	4,587
	Solid Grouted	1,351	5,579	675	5,579	1,802	7,439	901	7,439
	Hollow <sup>6</sup>	506	978	253	978	675	1,304	337	1,304

<sup>1</sup>For partially grouted masonry, allowable stresses may be linear interpolated between fully grouted and ungrouted masonry based on the amount of grouting.

<sup>2</sup>Capacities increased by a factor of 1.33 when considering load combinations that include wind or seismic.

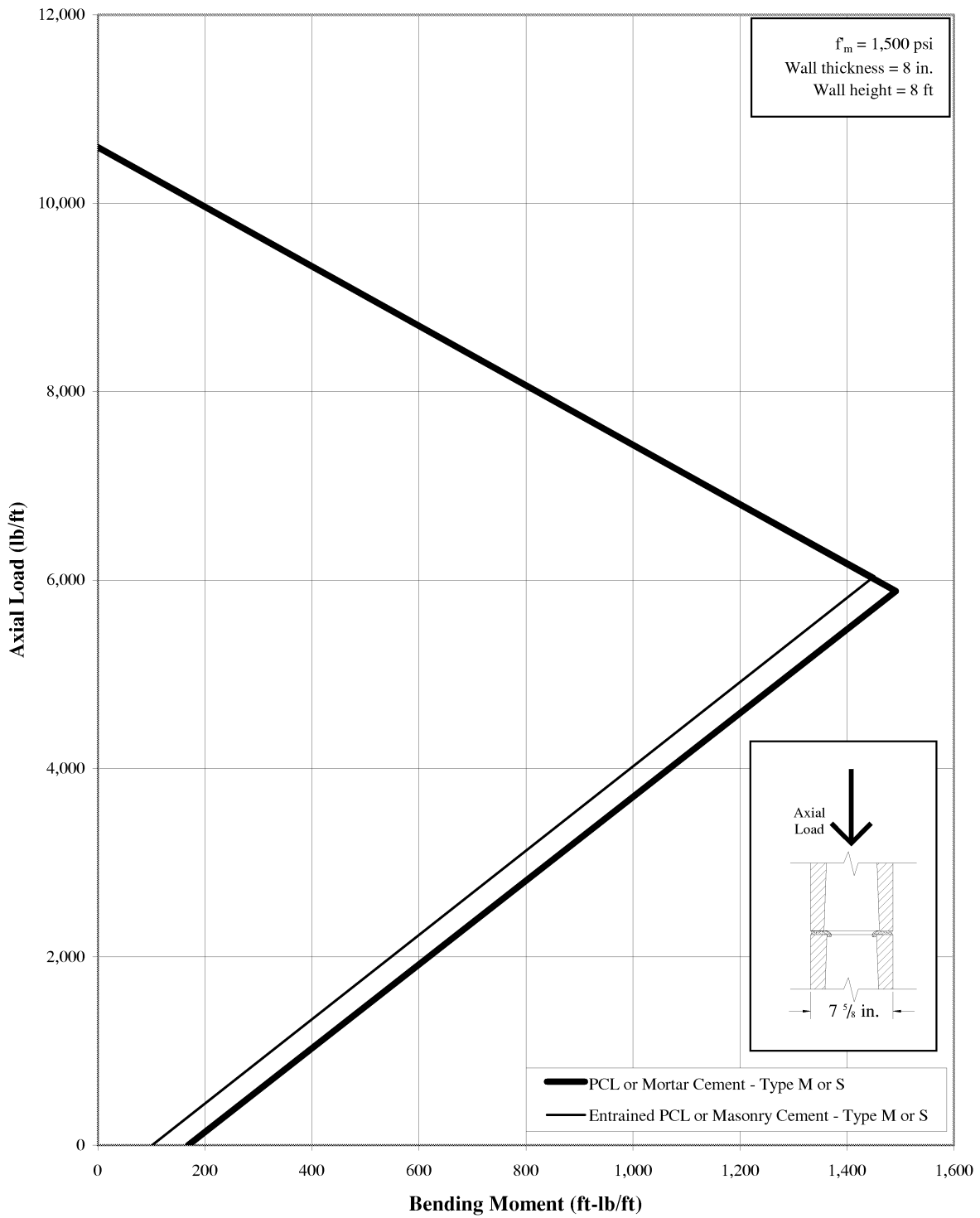
<sup>3</sup>Based on an allowable flexural tensile stress of 60 psi for solid and solid grouted units and 38 psi for hollow units.

<sup>4</sup>Based on allowable shear stress of 37 psi for hollow and solid units and 60 psi for solid grouted units.

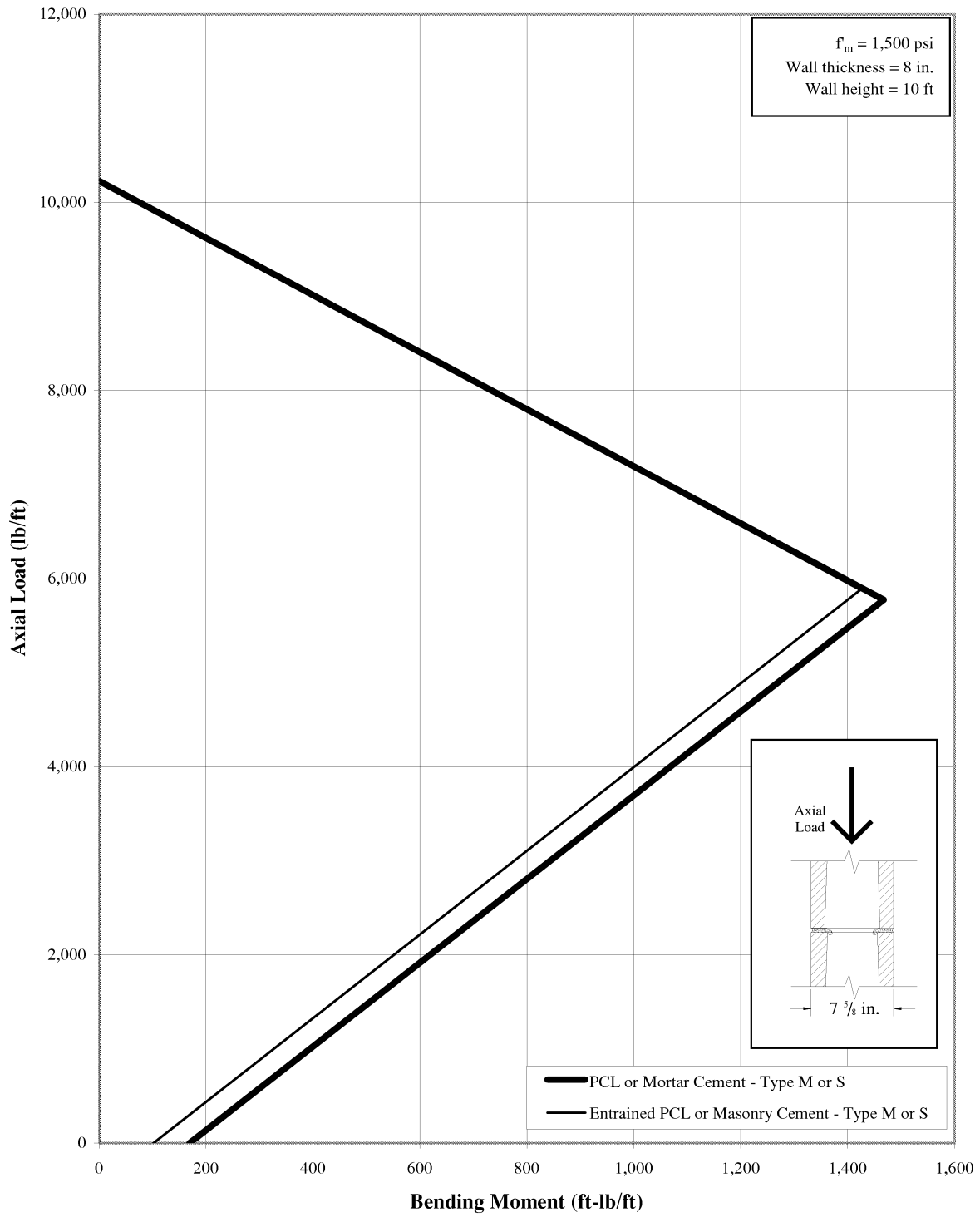
<sup>5</sup>Based on an allowable flexural tensile stress of 30 psi for solid and solid grouted units, and 19 psi for hollow units.

<sup>6</sup>Assumes face shell bedding of mortar.

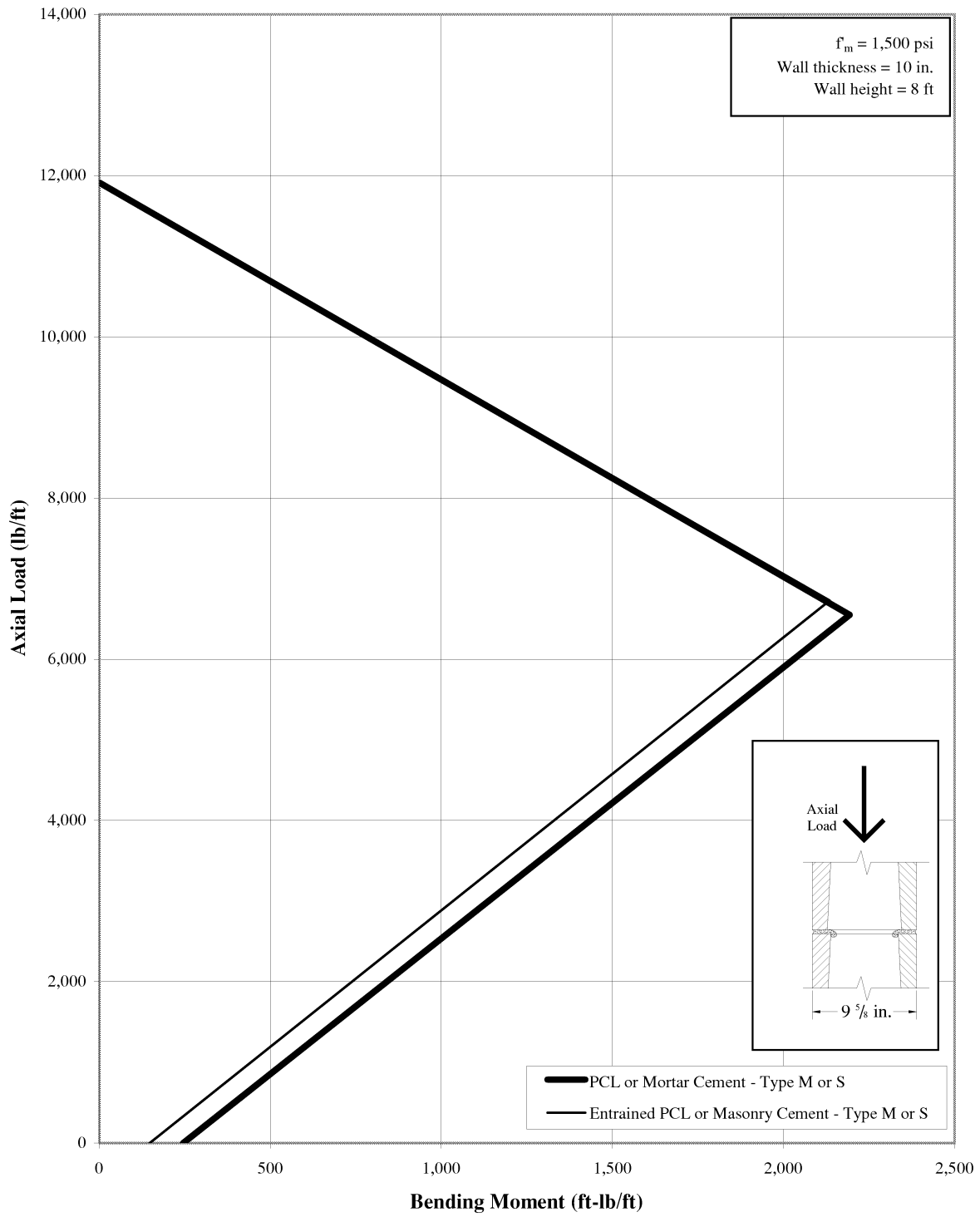
**Chart 2-22: Out-of-Plane Bending Moment and Axial Capacity Interaction Diagram for Unreinforced Masonry Spanning Vertically**



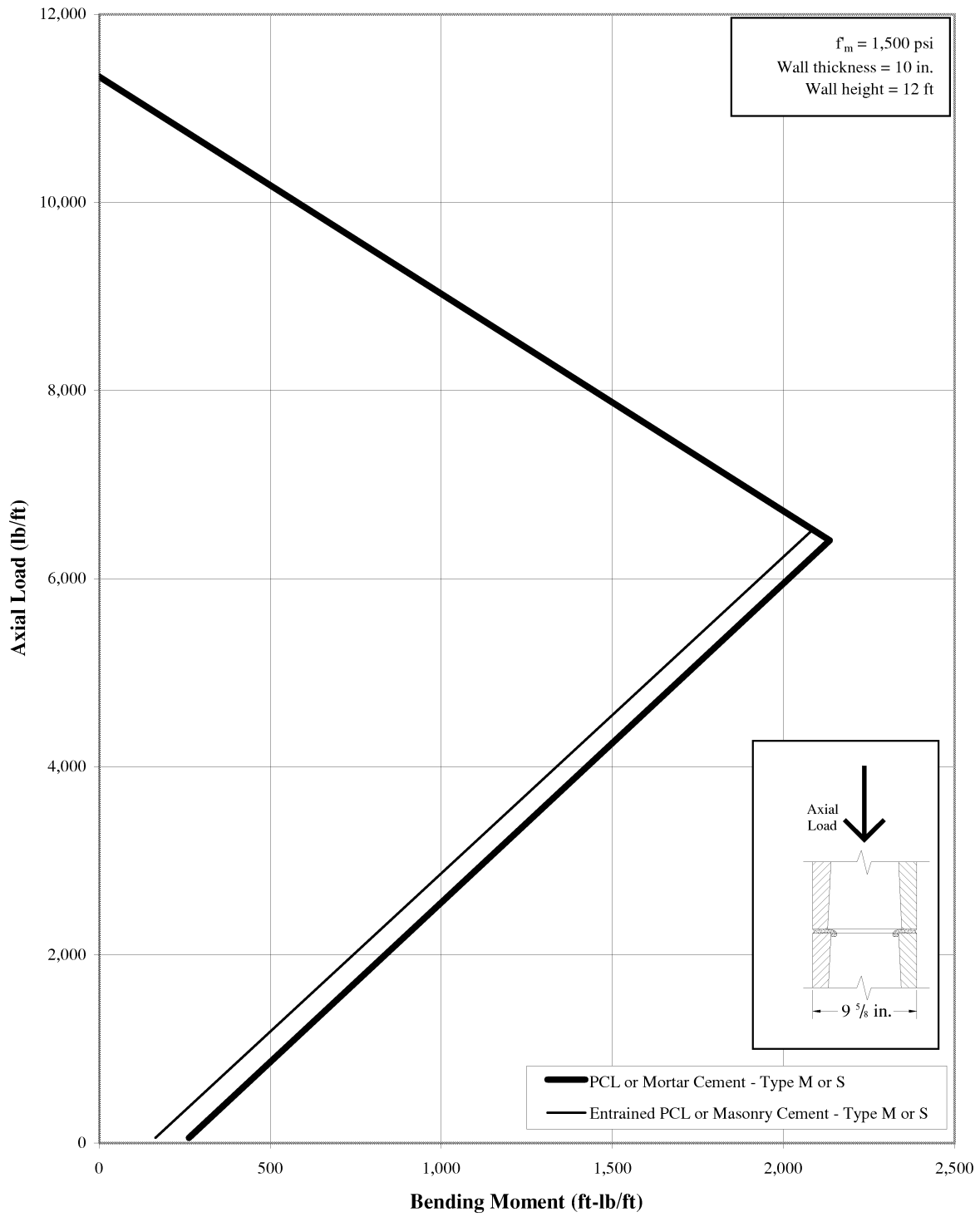
**Chart 2-23: Out-of-Plane Bending Moment and Axial Capacity Interaction Diagram for Unreinforced Masonry Spanning Vertically**



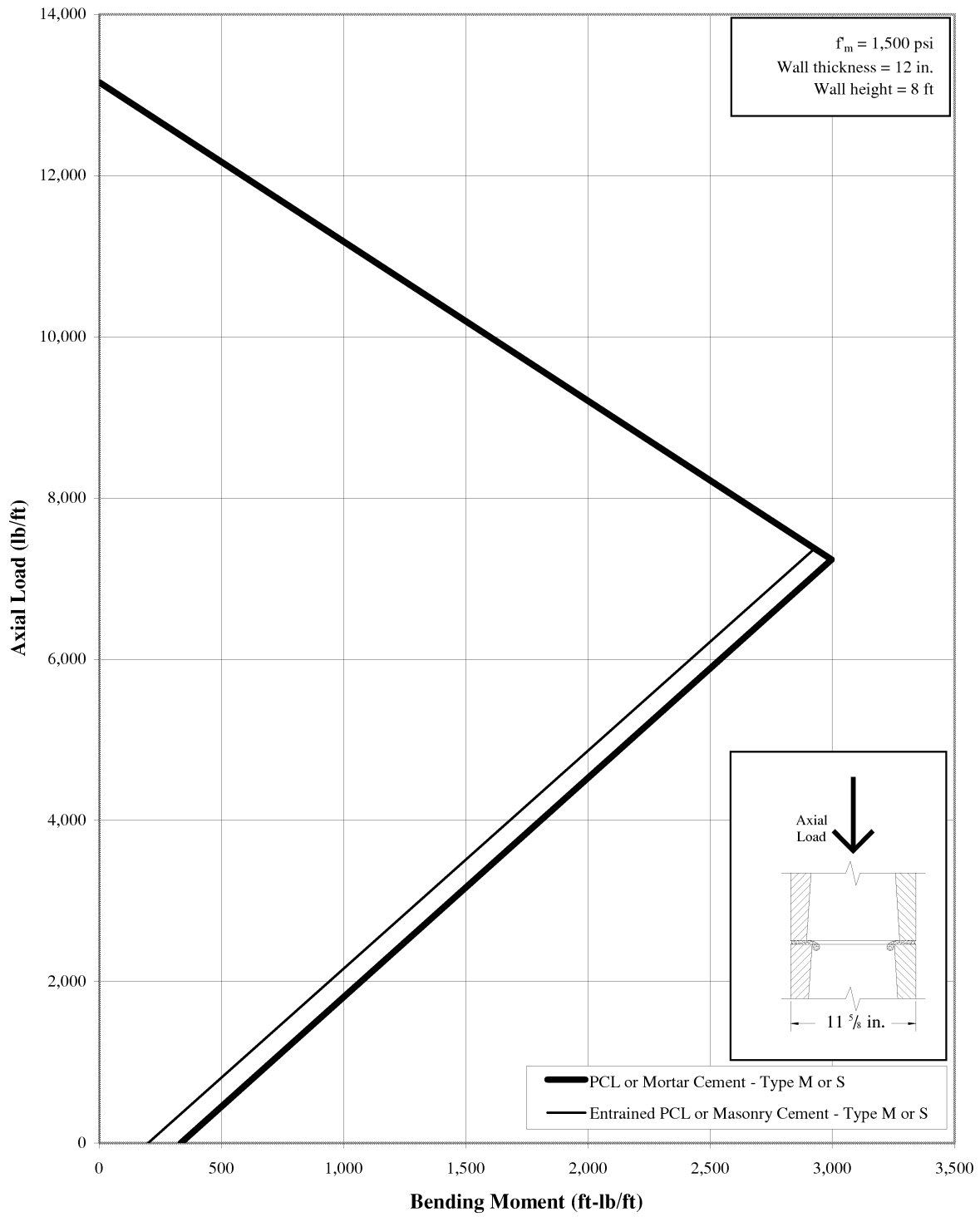
**Chart 2-24: Out-of-Plane Bending Moment and Axial Capacity Interaction Diagram for Unreinforced Masonry Spanning Vertically**



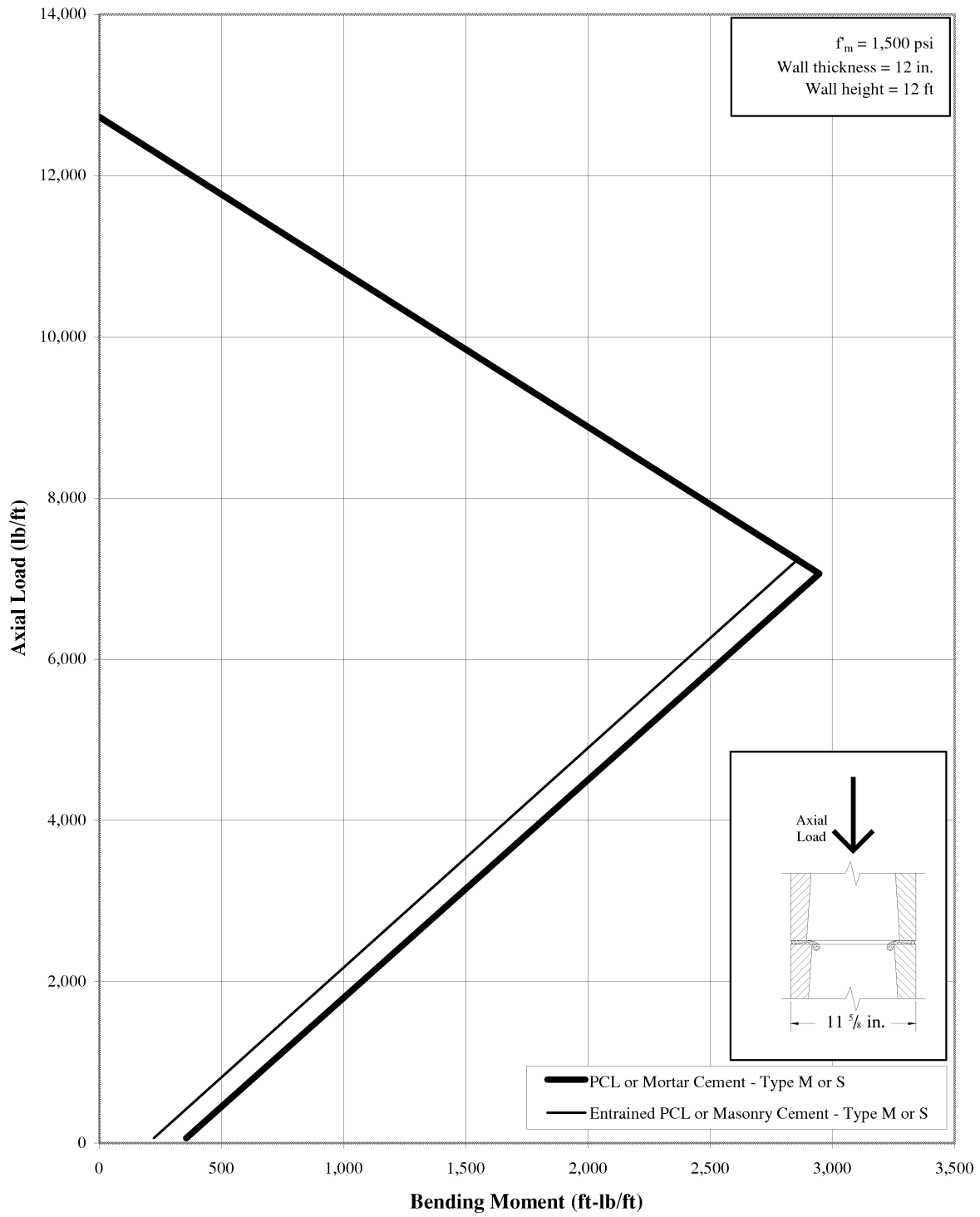
**Chart 2-25: Out-of-Plane Bending Moment and Axial Capacity Interaction Diagram for Unreinforced Masonry Spanning Vertically**



**Chart 2-26: Out-of-Plane Bending Moment and Axial Capacity Interaction Diagram for Unreinforced Masonry Spanning Vertically**



**Chart 2-27: Out-of-Plane Bending Moment and Axial Capacity Interaction Diagram for Unreinforced Masonry Spanning Vertically**





### 2.6.4 Pre-Engineered Design

When design circumstances allow, Tables 2-44 through 2-46 may be used as an alternative to the design options presented thus far in the manual. These tables have been rationally designed in accordance with the allowable stress design provisions of the MSJC (Ref. 8). Additional reinforcement alternatives may be appropriate and can be verified with an engineering analysis.

These tables assume two-way bending of the foundation walls (i.e., walls span both vertically from the footing to the roof or floor level and horizontally between reinforcement). Hence, the code-imposed limitation of reinforcement spacing (6 times the wall thickness or 72 inches) has been satisfied by verifying that the unreinforced section of masonry spanning between reinforcing bars has sufficient capacity to carry and distribute the anticipated loads.

Tables 2-44, 2-45, and 2-46 list reinforcement options for 8, 10 and 12-in. thick walls, respectively. The effective depths of reinforcement,  $d$ , (see Table notes) used are practical values, taking into account variations in face shell thickness, a range of bar sizes, minimum required grout cover, and construction tolerances for placing the reinforcing bars.

Tables 2-44, 2-43, and 2-44 are based on the following design criteria:

- No surcharges on the soil adjacent to the wall and no hydrostatic pressure.
- Wall design is not controlled by axial load.
- Wall is simply supported at top and bottom.
- Wall is grouted only at reinforced cells.
- Section properties are based on minimum face shell and web thicknesses in ASTM C 90 (Ref. 5A).

- The specified compressive strength of the masonry,  $f'_m$ , is 1,500 psi.
- The reinforcement yield strength,  $f_y$ , is 60,000 psi.
- The modulus of elasticity of the masonry,  $E_m$ , is 1,350,000 psi.
- The modulus of elasticity of the steel,  $E_s$ , is 29,000,000 psi.
- The maximum width of compression zone is six times the wall thickness. (Where reinforcement spacing exceeds this distance, the ability of the plain masonry outside the compression zone to distribute loads horizontally to the reinforced section was verified assuming two-way bending action.)
- The allowable tensile stress in the reinforcement,  $F_s$ , is 24,000 psi.
- The allowable compressive stress in the masonry,  $F_b$ , is  $1/3 f'_m$  (500 psi).
- The grout complies with ASTM C 476 (Ref. 5C).
- The masonry is laid in running bond using Type M or S mortar (either portland cement/lime, mortar cement, masonry cement, or air entrained portland cement/lime mortar unless indicated otherwise) and face shell bedding.

## 2.7 Empirical Design

### 2.7.1 Design Assumptions

As an alternative to the allowable stress design method presented in Section 2.6, users of this manual may also have the option of utilizing empirical design procedures where local codes permit. The empirical design method uses historical experience to proportion and size masonry elements. Empirical design is often used to design concrete masonry foundation walls due to its simplicity and history of successful performance.

Table 2-47 lists the allowable backfill heights for 8, 10 and 12-inch concrete

masonry foundation walls. Table 2-47 may be used for foundation walls up to 8 feet high under the following conditions (Ref. 8):

- Terrain surrounding the foundation wall is graded to drain surface water away from foundation walls.
- Backfill is drained to remove ground water away from foundation walls.
- The tops of foundation walls are laterally supported prior to backfilling.
- The length of foundation walls between perpendicular masonry walls or pilasters is a maximum of 3 times the foundation wall height.
- The backfill is granular and soil conditions in the area are non-expansive.

- The masonry is laid in running bond using Type M or S portland cement/lime or mortar cement mortar.
- Units meet the requirements of ASTM C 90 (Ref. 5A).

When these conditions are met, Table 2-47 may be used to design the foundation wall. Where these conditions cannot be met, the wall must be designed using an approved engineering analysis method.

**Table 2-47: Empirical Design of Foundation Walls**

<b>Wall Construction</b>	<b>Nominal Wall Thickness</b>	<b>Maximum Depth of Unbalanced Backfill</b>
Hollow Unit Masonry	8 in.	5 ft
	10 in.	6 ft
	12 in.	7 ft
Solid Unit Masonry	8 in.	5 ft
	10 in.	7 ft
	12 in.	7 ft
Fully Grouted Masonry	8 in.	7 ft
	10 in.	8 ft
	12 in.	8 ft

**Table 2-44: Pre-Engineered 8-inch Concrete Masonry Foundation Walls<sup>A</sup>**

Reinforcement Size and Spacing Required for Equivalent Fluid Pressure of:				
Wall Height (ft-in.)	Backfill Height (ft)	30 psf/ft	45 psf/ft	60 psf/ft
7'-4"	4	No. 5 at 120 in. o.c.	No. 6 at 120 in. o.c.	No. 5 at 72 in. o.c.
	5	No. 5 at 72 in. o.c.	No. 4 at 40 in. o.c.	No. 5 at 40 in. o.c.
	6	No. 4 at 40 in. o.c.	No. 5 at 40 in. o.c.	No. 6 at 40 in. o.c.
	7	No. 5 at 40 in. o.c.	No. 6 at 40 in. o.c.	No. 8 at 48 in. o.c.
8'-0"	4	No. 5 at 120 in. o.c.	No. 5 at 96 in. o.c.	No. 7 at 120 in. o.c. <sup>B</sup>
	5	No. 5 at 72 in. o.c. or No. 6 at 120 in. o.c. <sup>B</sup>	No. 4 at 32 in. o.c. or No. 8 at 120 in. o.c. <sup>B</sup>	No. 5 at 40 in. o.c. or No. 7 at 72 in. o.c. <sup>B</sup>
		No. 4 at 32 in. o.c. or No. 6 at 72 in. o.c. or <sup>B</sup>	No. 5 at 32 in. o.c. or No. 6 at 48 in. o.c. or	No. 5 at 24 in. o.c. or No. 6 at 40 in. o.c. or
	6	No. 7 at 96 in. o.c. <sup>B</sup>	No. 7 at 72 in. o.c. <sup>B</sup>	No. 8 at 56 in. o.c. <sup>B</sup>
		No. 5 at 40 in. o.c. or No. 6 at 56 in. o.c. or <sup>B</sup>	No. 5 at 24 in. o.c. or No. 6 at 32 in. o.c. or	No. 6 at 24 in. o.c. or No. 7 at 32 in. o.c. or
	7	No. 7 at 72 in. o.c. <sup>B</sup>	No. 8 at 56 in. o.c. <sup>B</sup>	No. 8 at 48 in. o.c.
8	No. 5 at 24 in. o.c. or No. 7 at 64 in. o.c. <sup>B</sup>	No. 6 at 24 in. o.c. or No. 8 at 48 in. o.c.	No. 5 at 8 in. o.c.	
9'-4"	4	No. 4 at 96 in. o.c. or No. 5 at 120 in. o.c.	No. 5 at 96 in. o.c. or No. 6 at 120 in. o.c.	No. 5 at 72 in. o.c. or No. 7 at 120 in. o.c. <sup>B</sup>
		No. 5 at 72 in. o.c. or No. 7 at 120 in. o.c. <sup>B</sup>	No. 5 at 48 in. o.c. or No. 8 at 120 in. o.c. <sup>B</sup>	No. 5 at 40 in. o.c. or No. 7 at 72 in. o.c. <sup>B</sup>
	6	No. 5 at 48 in. o.c. or No. 7 at 96 in. o.c. <sup>B</sup>	No. 5 at 32 in. o.c. or No. 8 at 72 in. o.c. <sup>B</sup>	No. 5 at 24 in. o.c. or No. 8 at 56 in. o.c. <sup>B</sup>
		No. 5 at 32 in. o.c. or No. 8 at 72 in. o.c. <sup>B</sup>	No. 5 at 24 in. o.c. or No. 8 at 56 in. o.c. <sup>B</sup>	No. 4 at 8 in. o.c. or No. 7 at 24 in. o.c.
	8	No. 6 at 32 in. o.c. or No. 8 at 56 in. o.c. <sup>B</sup>	No. 4 at 8 in. o.c. or No. 7 at 24 in. o.c.	No. 7 at 8 in. o.c.
	9	No. 6 at 24 in. o.c. or No. 8 at 48 in. o.c.	No. 6 at 8 in. o.c.	No. 8 at 8 in. o.c.
	10'-0"	4	No. 4 at 72 in. o.c. or No. 5 at 120 in. o.c.	No. 5 at 72 in. o.c. or No. 6 at 120 in. o.c.
No. 5 at 72 in. o.c. or No. 7 at 120 in. o.c. <sup>B</sup>			No. 5 at 48 in. o.c. or No. 8 at 120 in. o.c. <sup>B</sup>	No. 5 at 32 in. o.c. or No. 7 at 72 in. o.c. <sup>B</sup>
6		No. 5 at 48 in. o.c. or No. 7 at 96 in. o.c. <sup>B</sup>	No. 5 at 32 in. o.c. or No. 8 at 72 in. o.c. <sup>B</sup>	No. 6 at 32 in. o.c. or No. 8 at 56 in. o.c. <sup>B</sup>
		No. 5 at 32 in. o.c. or No. 8 at 72 in. o.c. <sup>B</sup>	No. 6 at 24 in. o.c. or No. 8 at 48 in. o.c.	No. 5 at 8 in. o.c. or No. 8 at 24 in. o.c.
8		No. 5 at 24 in. o.c. or No. 8 at 56 in. o.c. <sup>B</sup>	No. 5 at 8 in. o.c. or No. 8 at 24 in. o.c.	No. 8 at 8 in. o.c.
9		No. 6 at 24 in. o.c. or No. 8 at 40 in. o.c.	No. 7 at 8 in. o.c.	-----

<sup>A</sup>Effective depth of reinforcement is 4.625 inches.

<sup>B</sup>Use portland cement/lime or mortar cement mortar (Type M or S).

**Table 2-45: Pre-Engineered 10-inch Concrete Masonry Foundation Walls<sup>A</sup>**

Reinforcement Size and Spacing Required for Equivalent Fluid Pressure of:					
Wall Height (ft-in.)	Backfill Height (ft)	30 psf/ft	45 psf/ft	60 psf/ft	
7'-4"	4	No reinforcement.	No. 5 at 120 in. o.c.	No. 5 at 96 in. o.c.	
	5	No. 4 at 72 in. o.c. or No. 5 at 120 in. o.c.	No. 5 at 72 in. o.c. or No. 6 at 120 in. o.c. <sup>B</sup>	No. 5 at 64 in. o.c. or No. 7 at 120 in. o.c. <sup>B</sup>	
		6	No. 5 at 72 in. o.c. or No. 6 at 120 in. o.c. <sup>B</sup>	No. 5 at 56 in. o.c. or No. 7 at 96 in. o.c. <sup>B</sup>	No. 5 at 40 in. o.c. or No. 7 at 72 in. o.c. <sup>B</sup>
	7		No. 4 at 40 in. o.c. or No. 7 at 96 in. o.c. <sup>B</sup>	No. 5 at 40 in. o.c. or No. 6 at 72 in. o.c. <sup>B</sup>	No. 5 at 32 in. o.c. or No. 7 at 56 in. o.c. <sup>B</sup>
		8'-0"	4	No reinforcement.	No. 5 at 120 in. o.c.
5	No. 5 at 120 in. o.c.		No. 5 at 72 in. o.c.	No. 5 at 64 in. o.c.	
	6		No. 5 at 72 in. o.c. or No. 6 at 120 in. o.c. <sup>B</sup>	No. 5 at 56 in. o.c. or No. 7 at 96 in. o.c. <sup>B</sup>	No. 5 at 40 in. o.c. or No. 7 at 72 in. o.c. <sup>B</sup>
7			No. 5 at 56 in. o.c. or No. 7 at 96 in. o.c. <sup>B</sup>	No. 5 at 40 in. o.c. or No. 7 at 72 in. o.c. <sup>B</sup>	No. 5 at 24 in. o.c. or No. 7 at 56 in. o.c.
	8		No. 5 at 40 in. o.c. or No. 7 at 72 in. o.c. <sup>B</sup>	No. 5 at 24 in. o.c. or No. 8 at 64 in. o.c. <sup>B</sup>	No. 6 at 32 in. o.c. or No. 8 at 56 in. o.c.
9'-4"			4	No reinforcement.	No. 5 at 120 in. o.c.
	5	No. 4 at 72 in. o.c. or No. 5 at 120 in. o.c.	No. 5 at 72 in. o.c. or No. 7 at 120 in. o.c. <sup>B</sup>	No. 5 at 56 in. o.c. or No. 8 at 120 in. o.c. <sup>B</sup>	
		6	No. 5 at 72 in. o.c. or No. 7 at 120 in. o.c. <sup>B</sup>	No. 5 at 48 in. o.c. or No. 7 at 96 in. o.c. <sup>B</sup>	No. 5 at 32 in. o.c. or No. 7 at 72 in. o.c. <sup>B</sup>
	7		No. 5 at 48 in. o.c. or No. 7 at 96 in. o.c. <sup>B</sup>	No. 5 at 32 in. o.c. or No. 8 at 72 in. o.c. <sup>B</sup>	No. 5 at 24 in. o.c. or No. 8 at 56 in. o.c.
		8	No. 5 at 40 in. o.c. or No. 7 at 72 in. o.c. <sup>B</sup>	No. 5 at 24 in. o.c. or No. 8 at 64 in. o.c. <sup>B</sup>	No. 6 at 24 in. o.c. or No. 8 at 48 in. o.c.
	9		No. 5 at 24 in. o.c. or No. 7 at 56 in. o.c. <sup>B</sup>	No. 6 at 24 in. o.c. or No. 8 at 48 in. o.c.	No. 4 at 8 in. o.c. or No. 8 at 32 in. o.c.
10'-0"	4	No reinforcement.	No. 5 at 120 in. o.c.	No. 5 at 96 in. o.c.	
	5	No. 5 at 96 in. o.c.	No. 5 at 72 in. o.c.	No. 5 at 56 in. o.c.	
		6	No. 5 at 72 in. o.c. or No. 7 at 120 in. o.c. <sup>B</sup>	No. 5 at 48 in. o.c. or No. 8 at 96 in. o.c. <sup>B</sup>	No. 5 at 32 in. o.c. or No. 8 at 72 in. o.c. <sup>B</sup>
	7		No. 5 at 48 in. o.c. or No. 7 at 96 in. o.c. <sup>B</sup>	No. 5 at 32 in. o.c. or No. 8 at 72 in. o.c. <sup>B</sup>	No. 5 at 24 in. o.c. or No. 8 at 56 in. o.c.
		8	No. 5 at 32 in. o.c. or No. 7 at 72 in. o.c. <sup>B</sup>	No. 5 at 24 in. o.c. or No. 8 at 56 in. o.c.	No. 4 at 8 in. o.c. or No. 8 at 40 in. o.c.
	9		No. 5 at 24 in. o.c. or No. 7 at 56 in. o.c.	No. 6 at 24 in. o.c. or No. 8 at 48 in. o.c.	No. 4 at 8 in. o.c.
10'-0"	10	No. 6 at 32 in. o.c. or No. 8 at 56 in. o.c.	No. 4 at 8 in. o.c. or No. 8 at 32 in. o.c.	No. 6 at 8 in. o.c.	
	12'-0"	4	No reinforcement.	No. 5 at 120 in. o.c.	No. 5 at 96 in. o.c.
		5	No. 5 at 96 in. o.c.	No. 5 at 72 in. o.c.	No. 5 at 48 in. o.c.
			6	No. 5 at 64 in. o.c. or No. 7 at 120 in. o.c. <sup>B</sup>	No. 5 at 40 in. o.c. or No. 8 at 96 in. o.c.
		7		No. 5 at 40 in. o.c. or No. 8 at 96 in. o.c. <sup>B</sup>	No. 5 at 24 in. o.c. or No. 8 at 72 in. o.c. <sup>B</sup>
			8	No. 5 at 32 in. o.c. or No. 8 at 72 in. o.c. <sup>B</sup>	No. 6 at 24 in. o.c. or No. 8 at 48 in. o.c.
9		No. 5 at 24 in. o.c. or No. 8 at 56 in. o.c.		No. 4 at 8 in. o.c. or No. 8 at 40 in. o.c.	No. 5 at 8 in. o.c.
10	No. 8 at 48 in. o.c.	No. 5 at 8 in. o.c.	No. 8 at 8 in. o.c.		
11	No. 8 at 40 in. o.c.	No. 7 at 8 in. o.c.	-----		

<sup>A</sup>Effective depth of reinforcement is 6.625 inches.

<sup>B</sup>Use portland cement/lime or mortar cement mortar (Type M or S).

**Table 2-46: Pre-Engineered 12-inch Concrete Masonry Foundation Walls<sup>A</sup>**

Reinforcement Size and Spacing Required for Equivalent Fluid Pressure of:				
Wall Height (ft-in.)	Backfill Height (ft)	30 psf/ft	45 psf/ft	60 psf/ft
7'-4"	4	No reinforcement.	No reinforcement.	No. 5 at 120 in. o.c.
	5	No. 5 at 120 in. o.c.	No. 5 at 120 in. o.c.	No. 5 at 72 in. o.c.
	6	No. 4 at 72 in. o.c. or No. 5 at 120 in. o.c.	No. 5 at 72 in. o.c. or No. 7 at 120 in. o.c. <sup>B</sup>	No. 5 at 56 in. o.c. or No. 7 at 96 in. o.c. <sup>B</sup>
		No. 5 at 72 in. o.c. or No. 6 at 120 in. o.c. <sup>B</sup>	No. 5 at 56 in. o.c. or No. 7 at 96 in. o.c. <sup>B</sup>	No. 5 at 40 in. o.c. or No. 7 at 72 in. o.c.
	7	No. 5 at 72 in. o.c. or No. 6 at 120 in. o.c. <sup>B</sup>	No. 5 at 56 in. o.c. or No. 7 at 96 in. o.c. <sup>B</sup>	No. 5 at 40 in. o.c. or No. 7 at 72 in. o.c.
8'-0"	4	No reinforcement.	No reinforcement.	No. 5 at 120 in. o.c.
	5	No. 5 at 120 in. o.c.	No. 5 at 96 in. o.c.	No. 5 at 72 in. o.c.
	6	No. 5 at 96 in. o.c. or No. 6 at 120 in. o.c.	No. 5 at 72 in. o.c. or No. 7 at 120 in. o.c. <sup>B</sup>	No. 5 at 56 in. o.c. or No. 7 at 96 in. o.c. <sup>B</sup>
		No. 5 at 72 in. o.c. or No. 7 at 120 in. o.c. <sup>B</sup>	No. 5 at 48 in. o.c. or No. 7 at 96 in. o.c. <sup>B</sup>	No. 5 at 32 in. o.c. or No. 7 at 72 in. o.c.
	8	No. 5 at 56 in. o.c. or No. 7 at 96 in. o.c. <sup>B</sup>	No. 5 at 40 in. o.c. or No. 7 at 72 in. o.c.	No. 5 at 24 in. o.c. or No. 8 at 72 in. o.c.
9'-4"	4	No reinforcement.	No reinforcement.	No. 5 at 120 in. o.c.
	5	No. 4 at 96 in. o.c. or No. 5 at 120 in. o.c.	No. 5 at 96 in. o.c. or No. 6 at 120 in. o.c.	No. 5 at 72 in. o.c. or No. 7 at 120 in. o.c. <sup>B</sup>
		No. 5 at 96 in. o.c. or No. 6 at 120 in. o.c.	No. 5 at 64 in. o.c. or No. 7 at 120 in. o.c. <sup>B</sup>	No. 5 at 48 in. o.c. or No. 7 at 96 in. o.c. <sup>B</sup>
	7	No. 5 at 64 in. o.c. or No. 7 at 120 in. o.c. <sup>B</sup>	No. 5 at 40 in. o.c. or No. 8 at 96 in. o.c. <sup>B</sup>	No. 5 at 32 in. o.c. or No. 8 at 72 in. o.c.
		No. 5 at 48 in. o.c. or No. 7 at 96 in. o.c. <sup>B</sup>	No. 5 at 32 in. o.c. or No. 8 at 72 in. o.c.	No. 5 at 24 in. o.c. or No. 8 at 64 in. o.c.
	9	No. 5 at 40 in. o.c. or No. 7 at 72 in. o.c.	No. 5 at 24 in. o.c. or No. 8 at 64 in. o.c.	No. 4 at 8 in. o.c. or No. 8 at 48 in. o.c.
10'-0"	4	No reinforcement.	No. 5 at 120 in. o.c.	No. 5 at 120 in. o.c.
	5	No. 5 at 120 in. o.c.	No. 5 at 96 in. o.c.	No. 5 at 72 in. o.c.
	6	No. 5 at 96 in. o.c. or No. 6 at 120 in. o.c.	No. 5 at 64 in. o.c. or No. 7 at 120 in. o.c. <sup>B</sup>	No. 5 at 48 in. o.c. or No. 8 at 96 in. o.c. <sup>B</sup>
		No. 5 at 64 in. o.c. or No. 7 at 120 in. o.c. <sup>B</sup>	No. 5 at 40 in. o.c. or No. 8 at 96 in. o.c. <sup>B</sup>	No. 5 at 32 in. o.c. or No. 8 at 72 in. o.c.
	8	No. 5 at 48 in. o.c. or No. 8 at 96 in. o.c. <sup>B</sup>	No. 5 at 32 in. o.c. or No. 8 at 72 in. o.c.	No. 5 at 24 in. o.c. or No. 8 at 56 in. o.c.
		No. 5 at 32 in. o.c. or No. 7 at 72 in. o.c.	No. 5 at 24 in. o.c. or No. 8 at 64 in. o.c.	No. 6 at 24 in. o.c. or No. 8 at 48 in. o.c.
10	No. 5 at 24 in. o.c. or No. 8 at 72 in. o.c.	No. 6 at 24 in. o.c. or No. 8 at 48 in. o.c.	No. 4 at 8 in. o.c. or No. 8 at 32 in. o.c.	
12'-0"	4	No reinforcement.	No. 5 at 120 in. o.c.	No. 5 at 120 in. o.c.
	5	No. 5 at 120 in. o.c.	No. 5 at 72 in. o.c. or No. 8 at 120 in. o.c. <sup>B</sup>	No. 5 at 72 in. o.c. No. 8 at 96 in. o.c. <sup>B</sup>
	6	No. 5 at 72 in. o.c. or No. 6 at 120 in. o.c.	No. 5 at 56 in. o.c. or No. 8 at 120 in. o.c. <sup>B</sup>	No. 5 at 40 in. o.c. or No. 8 at 96 in. o.c. <sup>B</sup>
		No. 5 at 56 in. o.c. or No. 8 at 120 in. o.c. <sup>B</sup>	No. 5 at 32 in. o.c. or No. 8 at 96 in. o.c. <sup>B</sup>	No. 5 at 24 in. o.c. or No. 8 at 72 in. o.c.
	8	No. 5 at 40 in. o.c. or No. 8 at 96 in. o.c. <sup>B</sup>	No. 5 at 24 in. o.c. or No. 8 at 72 in. o.c.	No. 6 at 24 in. o.c. or No. 8 at 48 in. o.c.
		No. 5 at 32 in. o.c. or No. 8 at 72 in. o.c.	No. 6 at 24 in. o.c. or No. 8 at 48 in. o.c.	No. 4 at 8 in. o.c. or No. 8 at 40 in. o.c.
	10	No. 8 at 64 in. o.c.	No. 8 at 40 in. o.c.	No. 4 at 8 in. o.c.
	11	No. 8 at 48 in. o.c.	No. 8 at 32 in. o.c.	No. 5 at 8 in. o.c.
12	No. 8 at 40 in. o.c.	No. 5 at 8 in. o.c.	No. 7 at 8 in. o.c.	

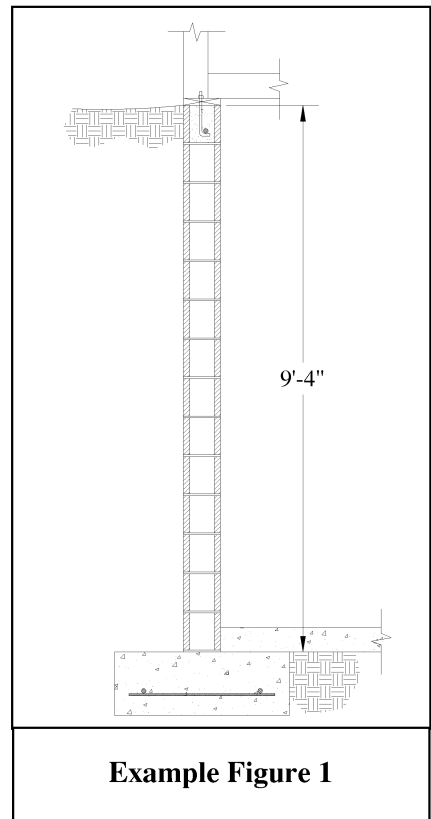
<sup>A</sup>Effective depth of reinforcement is 8.625 inches.

<sup>B</sup>Use portland cement/lime or mortar cement mortar (Type M or S).

## 2.8 Design Examples

### 2.8.1 Design Example No. 1

The following 9-foot 4-inch (112 in.) basement wall shown in Example Figure 1 is to be constructed of 8-inch concrete masonry units and Type S portland cement/lime mortar. The backfill, which is sand and gravel having a density of 120 pounds per cubic foot (pcf), will be over the entire height of the wall. The superstructure (walls, floors, roof, etc.) above the foundation will impose an axial live load of 750 pounds per linear foot (lb/ft) and an axial dead load of 1,050 (lb/ft). The masonry compressive strength is specified to be 1,500 psi. If necessary, Grade 60 reinforcement will be used. No other loads (surcharge, saturated soils, etc.) are known to be present. The wall is to be designed to span vertically between the footing and first floor as a simply supported element.



The first step is to determine the equivalent fluid pressure of the soil based on the known site conditions. From Table 2-3, the following equivalent soil fluid pressures are listed for a sand and gravel backfill having a unit weight of 120 pcf:

- Active pressure = 29 psf/ft
- At-rest pressure = 46 psf/ft
- Passive pressure = 505 psf/ft

Since the passive pressure is only used to evaluate the lateral resistance of the soil, and not the load exerted on the foundation by the soil, the choice for earth loading is between active and at-rest pressure. For most residential applications, the active pressure controls and is therefore assumed here. Hence, the equivalent fluid pressure of the soil is:

$$P_{EF} = 29 \text{ lb/ft}^2 \text{ per foot of depth}$$

The next step is to determine the maximum bending moment and shear forces resulting from the applied loads. From Tables 2-12a and 2-12b, based on a wall height of 9-foot 4-inches and an equivalent soil pressure of 30 psf/ft, the maximum bending moment and shear force is:

Maximum Bending Moment:

$$M_{\max} = 1,565 \text{ ft} - \text{lb per ft}$$

Maximum Shear Force:

$$V_{\max} = 871 \text{ lb per ft}$$

Note that these tables do not include pressures for 29 psf/ft as determined above. Rounding the soil pressure up slightly to 30 psf/ft is a conservative and common design practice. However, if a more exact value is necessary, the equations for the maximum moment and shear force illustrated in Figure 2-14a can be used as follows:

$$M_{\max} = \frac{w_B H^2}{9\sqrt{3}} = \frac{(29 \text{ psf})(9.33 \text{ ft})(9.33 \text{ ft})^2}{9\sqrt{3}} = 1,511 \text{ ft} - \text{lb per ft}$$

$$V_{\max} = \frac{1}{3} \rho K H^2 = \frac{(29 \text{ psf})(9.33 \text{ ft})^2}{3} = 842 \text{ lb per ft}$$

These new values for the maximum moment and shear force are slightly less than those determined from Tables 2-12a and 2-12b using a soil pressure of 30 psf/ft.

Based on the maximum moment of 1,511 ft-lb/ft and the shear force 842 lb/ft determined above, the last step is to design the foundation wall to carry these anticipated loads. Because unreinforced masonry is often the most cost effective form of construction, this should be the first option to investigate. From Table 2-40, the out-of-plane bending moment and shear capacity for hollow 8-inch concrete masonry units constructed with Type S portland cement/lime mortar is (note that the load combinations do not include wind or earthquake loads):

- Resisting moment =  $M_R = 168 \text{ ft-lb/ft}$
- Resisting shear =  $V_R = 550 \text{ lb/ft}$

Comparing these capacities to the applied moment and shear values of 1,511 ft-lb/ft and 842 lb/ft, respectively, the wall does not have sufficient strength to resist the design loads.

Because the wall cannot be designed to withstand the anticipated loads as unreinforced masonry, the next option is to incorporate reinforcement to increase the capacity of the wall. From Table 2-23, the out-of-plane bending moment and shear capacity for a wall reinforced with No. 4 bars at 8 inches on center and an effective depth of reinforcement of 5.375 in. is:

- Resisting moment =  $M_R = 2,277 \text{ ft-lb/ft}$
- Resisting shear =  $V_R = 2,498 \text{ lb/ft}$

Although these resisting capacities are greater than the applied loads, this option would require solidly grouted the wall. (Note that using No. 4 bars with a 16 inch spacing does not provide sufficient bending moment capacity.) Alternatively, a more cost-effective option would be to use larger diameter reinforcement and increase the spacing of the steel. From Table 2-26, the out-of-plane bending moment and shear capacity for a wall reinforced with No. 7 bars at 40 inches on center and an effective depth of reinforcement of 5.375 in. is:

- Resisting moment =  $M_R = 1,747 \text{ ft-lb/ft}$
- Resisting shear =  $V_R = 2,498 \text{ lb/ft}$

This option provides sufficient capacity to resist the anticipated loads and allows the steel/grout spacing to be increased to 40 inches, thereby reducing the cost of construction.

### 2.8.2 Design Example No. 2

In Design Example No. 1, the axial dead and live loads were not considered in the design. Typically, for residential construction, this is a conservative assumption as axial strength rarely controls the design of the foundation walls. However, in some circumstances, axially applied dead loads can help to resist lateral pressures from wind or soil. (In these cases, only dead loads can be assumed to help resist lateral loads, as other types of loads may not always be present.)

In this example, the interaction diagrams presented earlier in this chapter will be used to design the following basement wall:

- Backfill consists of *saturated* fine uniform sand having a unit weight of 110 pcf.
- The specified compressive strength of the masonry is 1,500 psi.

- The axial loads consist of 900 lb/ft live load and 2,500 lb/ft dead load.
- Wall is simply supported top and bottom.
- Type S portland/cement lime mortar is to be used.

As before, the first step is to determine the equivalent fluid pressure of the soil based on the known site conditions. Assuming active pressures, from Table 2-3 for a backfill material of fine uniform sand having a unit weight of 110 pcf, the equivalent fluid pressure is 40 psf/ft. Also, because this backfill material is saturated, the unit weight of water (62.4 pcf) must also be added to this pressure. Hence, the design lateral pressure is:

$$P_{EF} = 40 \text{ pcf} + 62.4 \text{ pcf} = 102.4 \text{ pcf per foot of depth}$$

Since the backfill height is not over the entire height of the wall, the ratio of the height of the backfill to the total wall height is needed.

$$\gamma = \frac{6.25 \text{ ft}}{9.33 \text{ ft}} = 0.67$$

A simple approach to determining the bending moment and shear force resulting from the applied lateral load is from Tables 2-15a and 2-15b assuming the backfill height extends to 0.7H and the equivalent fluid pressure of the soil is 105 psf/ft. Base on these assumptions:

- Maximum bending moment =  $M_{max} = 2,564 \text{ ft-lb/ft}$
- Maximum shear force =  $V_{max} = 1,718 \text{ lb/ft}$

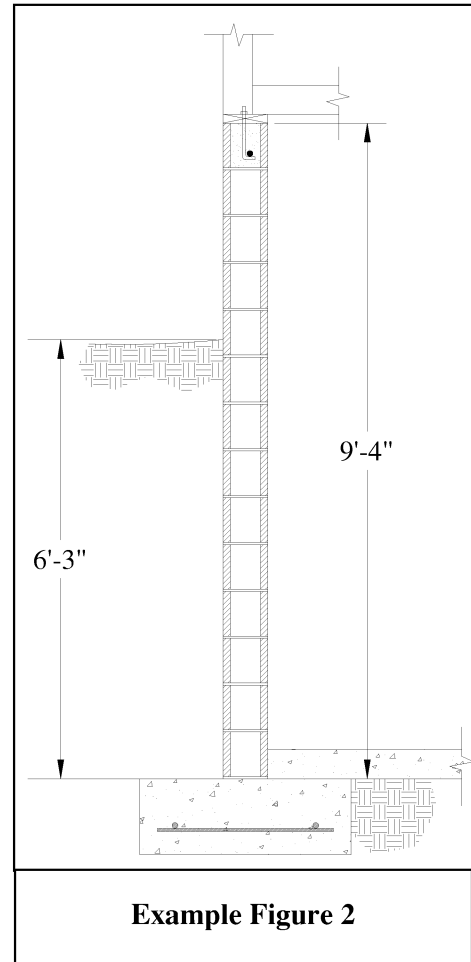
Alternatively, Figure 2-14b could be used to determine exactly the applied maximum bending moments and shear forces.

$$M_{max} = \left( \frac{1}{6} w_B (\gamma H)^2 \right) \left( 1 - \gamma + \frac{2\gamma}{3} \sqrt{\frac{\gamma}{3}} \right) =$$

$$\left( \frac{1}{6} (102.4)(6.25)(0.67)(9.33) \right) \left( 1 - 0.67 + \frac{(2)(\gamma)}{3} \sqrt{\frac{0.67}{3}} \right) = 2,257 \text{ ft-lb/ft}$$

$$V_{max} = \left( \frac{1}{2} w_B \gamma H \right) \left( 1 - \frac{\gamma}{3} \right) = ((0.5)(102.4)(6.25)(0.67)(9.33)) \left( 1 - \frac{0.67}{3} \right) = 1,555 \text{ lb/ft}$$

In order to satisfy the anticipated loads, a unit thickness, diameter of reinforcement, and effective depth need to be determined that will supply a resistance greater than the applied bending moment of 2,257 ft-lb/ft and shear force of 1,555 lb/ft.





If a 10-inch wall thickness were selected, in order to maximize the distance between reinforcement, the largest practical effective depth and diameter of steel is selected. From Table 2-32 for No. 8 bars at 48 inches on center with an effective depth of 6.375 inches:

- Resisting moment =  $M_R = 2,281$  ft-lb/ft
- Resisting shear =  $V_R = 2,962$  lb/ft

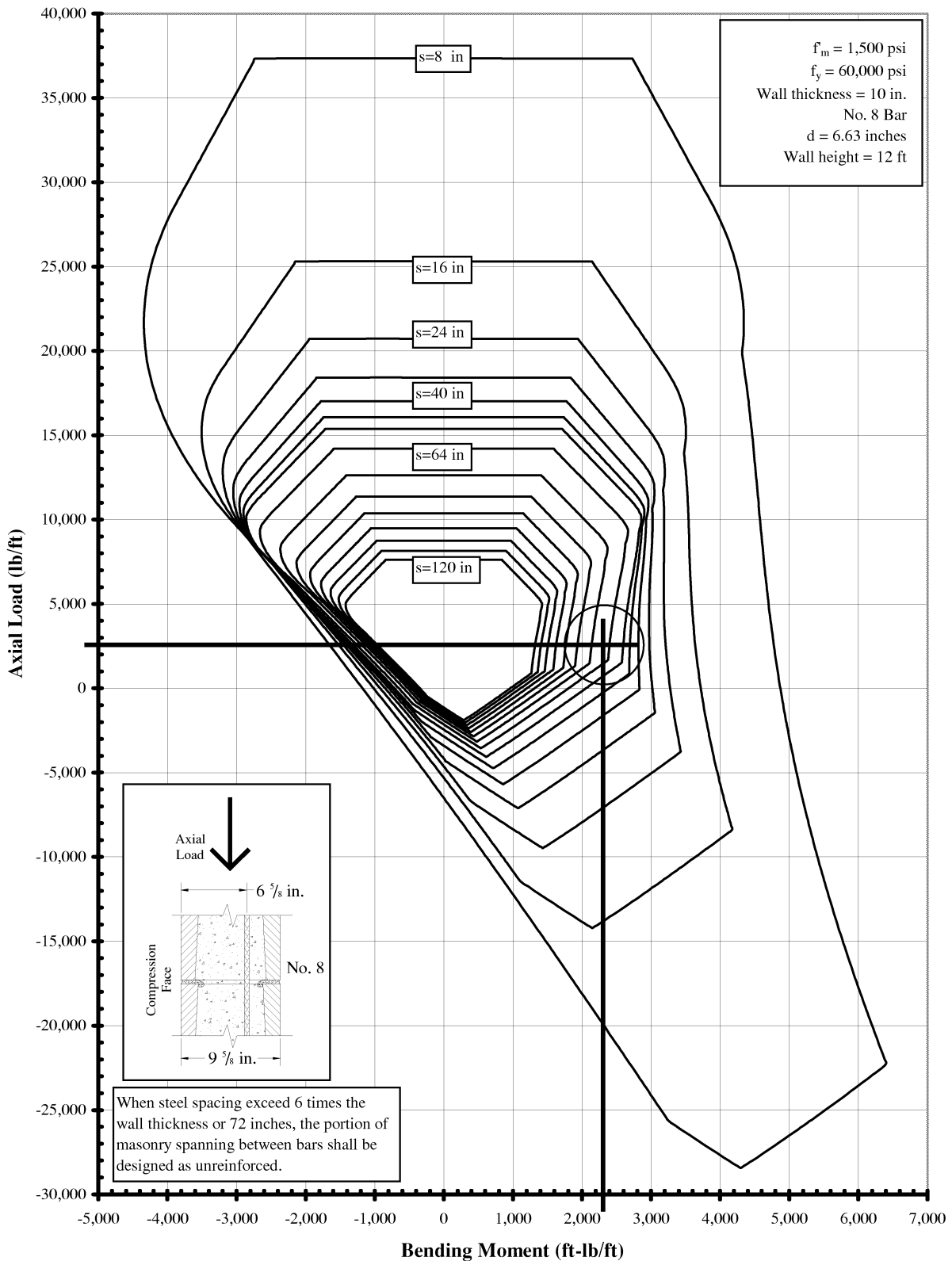
Since these resisting values are greater than the applied maximum values, this design is adequate.

Alternatively, the axial dead load could be taken into consideration in adding to the resistance of the cross-section. From Chart 2-19 for a 10-inch wall thickness and No. 8 bars with an effective depth of 6.63 inches (note that Chart 2-19 applies to a 12 foot wall height, which can be conservatively applied to the 9.33 foot wall in this design), the intersection of the applied bending moment of 2,257 ft-lb/ft and axial dead load falls just inside of the curve for a steel spacing of 64 inches as shown on the following page.

Because this intersection falls *within* the curve for a steel spacing of 64 inches, this configuration would be sufficient for the anticipated loads. However, since the steel spacing of 64 inches exceeds 6 times the nominal wall thickness of 60 inches, the portion of masonry spanning between the bars would need to be designed as unreinforced *or* the steel spacing decreased to 56 inches on center (a value less than or equal to 6 times the nominal wall thickness).

Comparing the maximum moment and shear force determined above to the resisting values in Table 2-42 for unreinforced masonry spanning horizontally, there is not value in Table 2-42 that would be able to resist the applied maximum bending moment and shear force. Hence, the maximum steel spacing for this case would be 56 inches on center.

**Chart 2-19: Out-of-Plane Bending Moment and Axial Capacity Interaction Diagram for Reinforced Masonry Spanning Vertically**





## Chapter 3

# Energy Conservation and Noise Abatement

### 3.1 Energy Conservation with Foundation Walls

With an increase in awareness of energy usage and environmental issues, the energy efficiency of below grade walls has become a principal design consideration for foundation walls within recent years. The International Energy Conservation Code (IECC) (Ref. 17) includes requirements to limit heat loss from basement and foundation walls. This is typically accomplished either by insulating the floor above the basement or crawl space or, if the basement will be used as habitable space, by insulating the walls. The thermal properties of the wall, as well as the interior conditions and the moderating effect of the soil, influence the actual performance of below grade walls.

The wide variety of available concrete masonry wall construction configurations provides for a number of insulating options. Single wythe masonry construction can easily accommodate exterior, integral, or interior insulation. Each masonry wall design has different advantages and limitations with regard to each of these insulation strategies. The choice of insulation will depend on the desired thermal properties, the local climate conditions, ease of construction, cost, and other design criteria.

#### 3.1.1 Building Code Requirements

For the purposes of establishing heating or cooling criteria, the IECC (Ref. 17) defines basement walls as follows:

“The opaque portion of a wall which encloses one side of a basement and having an average below-grade area greater than or equal to 50 percent of the total wall area, including openings.”

In other words, if one-half or more of the area of a wall is below grade, the IECC (Ref. 17) classifies such a wall as a *basement wall*.

Like most energy codes, the IECC requires basement and crawl space walls to meet minimum thermal requirements to limit heat loss or cooling demand. These requirements are typically expressed in terms of steady state (not changing with respect to time) heat flow factors such as R-values and U-factors.

Like most design criteria, the insulation (R-value) necessary to meet local or state building code requirements for different structures varies considerably depending upon the controlling environmental conditions. Hence, the user is deferred to local documentation to ascertain this information. Generally however, little or no additional insulation is necessary for residential concrete masonry construction in a majority of the United States.

#### 3.1.2 Typical Thermal Values

The thermal performance of a masonry wall depends on its thermal resistance (R-value), the thermal mass characteristics of the wall, as well as the characteristics of the soil and local climate conditions. The R-value describes the ability to resist heat flow and is determined by the size and properties of the masonry units and if present, the type and location of insulation and finish materials.

Thermal mass describes the ability of materials like concrete masonry to store heat. Masonry walls remain warm or cool long after the heat or air-conditioning has shut off. This characteristic can be used to reduce heating and cooling loads, moderate

indoor temperatures, and shift heating and cooling utility loads to off-peak hours. The impact of thermal mass varies most dramatically with climate and insulation position. Thermal mass is most effective with exterior or integral insulation for most areas of the United States. This keeps the masonry (mass) directly in contact with the interior conditioned air.

R-values are widely recognized, and are used to describe insulation effectiveness. R-values describe the resistance to steady state heat flow; a higher R-value means a higher resistance, or more insulating ability. This steady state estimate of heat loss is a simplification, because in reality temperatures are changing constantly.

The inverse of the R-value is the U-factor, which describes the rate of heat transfer. A higher U-factor indicates a higher heat flow rate or less insulating ability. Design U-factors and R-values typically include the effects of the air films on the interior and exterior of the construction assembly. The conductance of the air film quantifies the rate at which heat is transferred from the wall to the surrounding environment.

Heat capacity indicates the ability of a material to store heat. Materials with high heat capacities, such as concrete masonry, have significant heat storage capability and thermal mass effects.

Tables 3-1 through 3-4 list R-values for a variety of concrete masonry walls and construction configurations. Thermal values are correlated to unit density, since the thermal conductivity of concrete increases with concrete density.

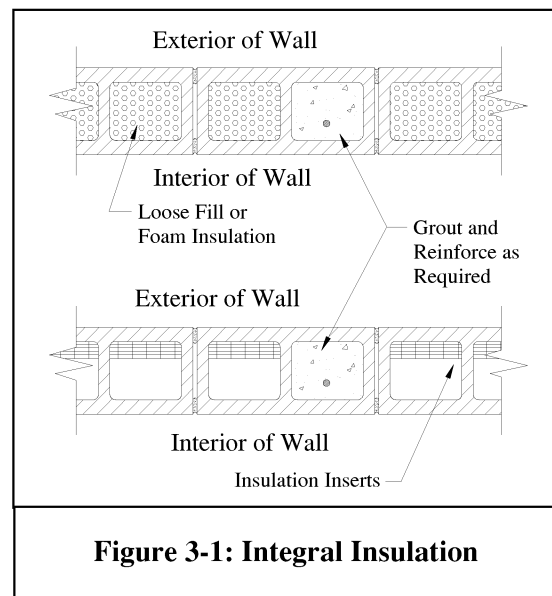
### 3.2 Insulation Strategies

Insulation tactics can generally be broken up into three different configurations for

concrete masonry: integral, exterior, and interior insulations. These insulation strategies may be used independently or in combination with on another.

#### 3.2.1 Integral Insulation

Integral insulation refers to insulation placed within the wall, usually in the cores of concrete masonry units. Figure 3-1 illustrates typical integral insulation details in single-wythe masonry walls. Integral insulation is typically in the form of molded polystyrene inserts, expanded perlite or vermiculite granular fills, or foamed-in-place insulation.



**Figure 3-1: Integral Insulation**

When using integral or exterior insulation strategies, architectural concrete masonry units can be used to provide a finished surface. By using smooth molded units at the base of a wall, screeding of an abutting concrete slab is facilitated, and the space between the units and the slab may be used to install an electric race as a molding strip. The remainder of the wall may be constructed of smooth, split-face, split ribbed, ground face, scored, or other architectural concrete masonry units.

<b>Table 3-1: Average R-Values<sup>e</sup> For 6 in. Concrete Masonry Walls, hr ft<sup>2</sup> °F/Btu<sup>a</sup></b>						
Construction	Density of Masonry Units, pcf	Hollow Unit Construction	Cores Filled with <sup>b</sup>			
			Perlite	Vermiculite	Polyurethane foamed insulation	Solid Grouted
Exposed block, both sides	85	2.4	5.3	5.0	5.9	1.7
	105	2.1	4.0	3.8	4.3	1.5
	125	1.8	3.0	2.9	3.1	1.4
	135	1.7	2.6	2.5	2.7	1.3
½ in. gypsum board on furring	85	3.8	6.7	6.3	7.3	3.1
	105	3.5	5.4	5.2	5.7	2.9
	125	3.2	4.4	4.3	4.5	2.8
	135	3.1	4.0	3.9	4.1	2.7
1 in. expanded polystyrene	85	7.8	10.7	10.3	11.3	7.1
	105	7.5	9.4	9.2	9.7	6.9
	125	7.2	8.4	8.3	8.5	6.8
	135	7.1	8.0	7.9	8.1	6.7
1 in. extruded polystyrene <sup>c</sup>	85	8.8	11.7	11.3	12.3	8.1
	105	8.5	10.4	10.2	10.7	7.9
	125	8.2	9.4	9.3	9.5	7.8
	135	8.1	9.0	8.9	9.1	7.7
1 in. polyisocyanurate <sup>d</sup>	85	12.2	15.2	14.8	15.8	11.6
	105	12.0	13.8	13.7	14.1	11.4
	125	11.7	12.8	12.7	13.0	11.2
	135	11.6	12.4	12.4	12.5	11.2
2 x 4 furring with R 13 batt and ½ in. gypsum on furring	85	13.2	16.1	15.7	16.7	12.5
	105	12.9	14.8	14.6	15.1	12.3
	125	12.6	13.8	13.7	13.9	12.2
	135	12.5	13.4	13.3	13.5	12.1

<sup>a</sup>Assumes mortar joints are 3/8 in. thick, with face shell mortar bedding assumed. Unit dimensions based on ASTM C 90 (Ref. 5A). Surface air films are included.

<sup>b</sup>Values apply when all masonry cores are filled completely. Grout density is 140 pcf.

<sup>c</sup>Installed over wood furring. Includes ½ in. gypsum board and non-reflective air space.

<sup>d</sup>Installed over wood furring. Includes ½ in. gypsum board and reflective air space.

<sup>e</sup>Ref. 12F

<b>Table 3-2: Average R-Values<sup>e</sup> For 8 in. Concrete Masonry Walls, hr ft<sup>2</sup> °F/Btu<sup>a</sup></b>						
Construction	Density of Masonry Units, pcf	Hollow Unit Construction	Cores Filled with <sup>b</sup>			
			Perlite	Vermiculite	Polyurethane foamed insulation	Solid Grouted
Exposed block, both sides	85	2.5	7.1	6.6	8.0	2.0
	105	2.2	5.2	4.9	5.6	1.7
	125	2.0	3.8	3.7	4.0	1.5
	135	1.9	3.3	3.2	3.4	1.5
½ in. gypsum board on furring	85	3.9	8.5	8.0	9.4	3.4
	105	3.6	6.6	6.3	7.0	3.1
	125	3.4	5.2	5.1	5.4	2.9
	135	3.3	4.7	4.6	4.8	2.9
1 in. expanded polystyrene	85	7.9	12.5	12.0	13.4	7.4
	105	7.6	10.6	10.3	11.0	7.1
	125	7.4	9.2	9.1	9.4	6.9
	135	7.3	8.7	8.6	8.8	6.9
1 in. extruded polystyrene <sup>c</sup>	85	8.9	13.5	13.0	14.4	8.4
	105	8.6	11.6	11.3	12.0	8.1
	125	8.4	10.2	10.1	10.4	7.9
	135	8.3	9.7	9.6	9.8	7.9
1 in. polyisocyanurate <sup>d</sup>	85	12.4	17.0	16.4	17.8	11.8
	105	12.1	15.1	14.8	15.5	11.6
	125	11.9	13.7	13.5	13.9	11.4
	135	11.7	13.1	13.0	13.2	11.4
2 x 4 furring with R 13 batt and ½ in. gypsum on furring	85	13.3	17.9	17.4	18.8	12.8
	105	13.0	16.0	15.7	16.4	12.5
	125	12.8	14.6	14.5	14.8	12.3
	135	12.7	14.1	14.0	14.2	12.3

<sup>a</sup>Assumes mortar joints are 3/8 in. thick, with face shell mortar bedding assumed. Unit dimensions based on ASTM C 90 (Ref. 5A). Surface air films are included.

<sup>b</sup>Values apply when all masonry cores are filled completely. Grout density is 140 pcf.

<sup>c</sup>Installed over wood furring. Includes ½ in. gypsum board and non-reflective air space.

<sup>d</sup>Installed over wood furring. Includes ½ in. gypsum board and reflective air space.

<sup>e</sup>Ref. 12F

<b>Table 3-3: Average R-Values<sup>e</sup> For 10 in. Concrete Masonry Walls, hr ft<sup>2</sup> °F/Btu<sup>a</sup></b>						
Construction	Density of Masonry Units, pcf	Hollow Unit Construction	Cores Filled with <sup>b</sup>			
			Perlite	Vermiculite	Polyurethane foamed insulation	Solid Grouted
Exposed block, both sides	85	2.7	8.5	7.9	9.5	2.2
	105	2.3	6.1	5.8	6.6	1.9
	125	2.1	4.4	4.3	4.6	1.7
	135	2.0	3.7	3.6	3.9	1.6
½ in. gypsum board on furring	85	4.1	9.9	9.3	10.9	3.6
	105	3.7	7.5	7.2	8.0	3.3
	125	3.5	5.8	5.7	6.0	3.1
	135	3.4	5.1	5.0	5.3	3.0
1 in. expanded polystyrene	85	8.1	13.9	13.3	14.9	7.6
	105	7.7	11.5	11.2	12.0	7.3
	125	7.5	9.8	9.7	10.0	7.1
	135	7.4	9.1	9.0	9.3	7.0
1 in. extruded polystyrene <sup>c</sup>	85	9.1	14.9	14.3	15.9	8.6
	105	8.7	12.5	12.2	13.0	8.3
	125	8.5	10.8	10.7	11.0	8.1
	135	8.4	10.1	10.0	10.3	8.0
1 in. polyisocyanurate <sup>d</sup>	85	12.5	18.4	17.8	19.3	12.1
	105	12.2	16.0	15.7	16.5	11.8
	125	11.9	14.3	14.1	14.5	11.6
	135	11.8	13.6	13.5	13.7	11.5
2 x 4 furring with R 13 batt and ½ in. gypsum on furring	85	13.5	19.3	18.7	20.3	13.0
	105	13.1	16.9	16.6	17.4	12.7
	125	12.9	15.2	15.1	15.4	12.5
	135	12.8	14.5	14.4	14.7	12.4

<sup>a</sup>Assumes mortar joints are 3/8 in. thick, with face shell mortar bedding assumed. Unit dimensions based on ASTM C 90 (Ref. 5A). Surface air films are included.

<sup>b</sup>Values apply when all masonry cores are filled completely. Grout density is 140 pcf.

<sup>c</sup>Installed over wood furring. Includes ½ in. gypsum board and non-reflective air space.

<sup>d</sup>Installed over wood furring. Includes ½ in. gypsum board and reflective air space.

<sup>e</sup>Ref. 12F



Construction	Density of Masonry Units, pcf	Hollow Unit Construction	Cores Filled with <sup>b</sup>			
			Perlite	Vermiculite	Polyurethane foamed insulation	Solid Grouted
Exposed block, both sides	85	2.8	10.3	9.6	11.5	2.4
	105	2.4	7.4	7.0	8.0	2.1
	125	2.2	5.3	5.1	5.5	1.9
	135	2.0	4.4	4.3	4.6	1.8
½ in. gypsum board on furring	85	4.2	11.7	11.0	12.9	3.8
	105	3.8	8.8	8.4	9.4	3.5
	125	3.6	6.7	6.5	6.9	3.3
	135	3.4	5.8	5.7	6.0	3.2
1 in. expanded polystyrene	85	8.2	15.7	15.0	16.9	7.8
	105	7.8	12.8	12.4	13.4	7.5
	125	7.6	10.7	10.5	10.9	7.3
	135	7.4	9.8	9.7	10.0	7.2
1 in. extruded polystyrene <sup>c</sup>	85	9.2	16.7	16.0	17.9	8.8
	105	8.8	13.8	13.4	14.4	8.5
	125	8.6	11.7	11.5	11.9	8.3
	135	8.4	10.8	10.7	11.0	8.2
1 in. polyisocyanurate <sup>d</sup>	85	12.6	20.2	19.4	21.4	12.3
	105	12.3	17.3	16.9	17.8	12.0
	125	12.0	15.1	14.9	15.4	11.8
	135	11.9	14.3	14.2	14.5	11.7
2 x 4 furring with R 13 batt and ½ in. gypsum on furring	85	13.6	21.1	20.4	22.3	13.2
	105	13.2	18.2	17.8	18.8	12.9
	125	13.0	16.1	15.9	16.3	12.7
	135	12.8	15.2	15.1	15.4	12.6

<sup>a</sup>Assumes mortar joints are 3/8 in. thick, with face shell mortar bedding assumed. Unit dimensions based on ASTM C 90 (Ref. 5A). Surface air films are included.

<sup>b</sup>Values apply when all masonry cores are filled completely. Grout density is 140 pcf.

<sup>c</sup>Installed over wood furring. Includes ½ in. gypsum board and non-reflective air space.

<sup>d</sup>Installed over wood furring. Includes ½ in. gypsum board and reflective air space.

<sup>e</sup>Ref. 12F

When using granular insulating fills, the insulation is placed in the masonry as the wall is constructed or once the wall has been completed. Usually, the fills are poured directly from bags into the cores. With loose-fill, some small settlement of the insulation may occur over time.

Care must be taken during construction to ensure granular fills do not flow out of any holes in the wall system. Weep holes should have wicks or non-corrosive screens to contain the fill while allowing water drainage. Bee holes or other gaps in the

mortar joints should be filled prior to adding the insulation. In addition, post-installed anchors placed in an insulated cell after the insulation has been installed will require special installation procedures to prevent loss of the granular fill.

Foamed-in-place insulation is installed after the wall is constructed. The installer either fills the cores from the top of the wall or drills small holes in the masonry face shells and then pumps the foam through the holes. Foams may be sensitive to temperature, mixing conditions, or other factors.

Therefore, manufacturers' instructions should be carefully followed to ensure complete coverage and to avoid excessive shrinkage due to improper mixing or placing of the foam.

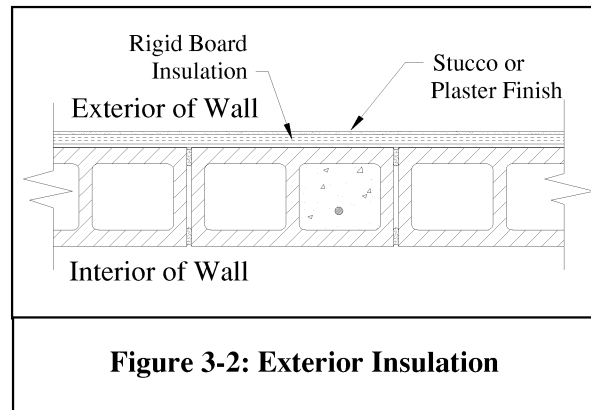
Polystyrene inserts may be placed in the cores of conventional masonry units, or they may be used in conjunction with specially designed concrete masonry units. Inserts are available in many shapes and sizes to provide a range of thermal performance and to accommodate various construction conditions. The inserts can be installed in the cores of the units at the time of manufacture, eliminating the extra step of insulating the wall during construction, or installed at the construction site. While the benefit of insulation inserts is typically increased when placed toward the exterior of the wall, this depends upon the specific application, local climate conditions, and the general configuration of the units used.

In some applications, vertical or horizontal reinforcement may be required for structural performance. Cores to be grouted are isolated from cores to be insulated by placing mortar on the webs to confine the grout. Granular or foam insulation is placed in all ungrouted cores within the wall. Thermal resistance is then determined based on the average R-value of the wall area (Ref. 12F). Rigid inserts may be designed to accommodate, within the same core, reinforcing steel and grout to provide both thermal protection and increased structural capacity.

### 3.2.2 Exterior Insulation

Exterior insulated walls, as shown in Figure 3-2, have insulation placed on the outside of the masonry. For below grade construction, rigid board insulation is typically adhered to the exterior of concrete masonry walls. This insulation strategy minimizes the effect of

thermal bridging through the masonry webs, since the wall is enveloped in a continuous layer of insulation, but it also subjects the insulation to potential damage during backfilling and can provide hidden tunneling for termites.



**Figure 3-2: Exterior Insulation**

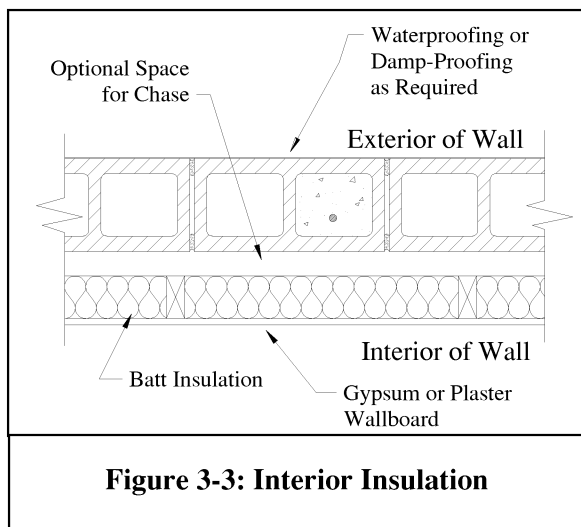
Insulation on the exterior of below grade portions of the wall is temporarily held in place by adhesives until the backfill is placed. That portion of the rigid board that extends above grade should be mechanically attached and protected. The protective finish on the above grade portion of the wall helps maintain the durability, integrity, and effectiveness of the insulation.

Materials used for exterior insulation on below grade walls must be strong enough to resist crushing under the pressure of the backfill material. Similarly, where the exterior insulation will be installed on the outside of the waterproofing or damp-proofing, the insulation must be able to withstand ground moisture and any fertilizers or other chemicals that may be present in the soil.

### 3.2.3 Interior Insulation

Interior insulation typically consists of insulation installed between attached studs or furring strips as shown in Figure 3-3. Although this insulation method reduces interior floor space, it is generally cost-effective if the studs or fur strips are needed

to install gypsum wallboard or other interior finish. In addition to being needed for installing interior finishes, the typical framing used for interior insulation provides a place to run electric and plumbing lines. The insulation may be fibrous batt, rigid board (polystyrene or polyisocyanurate), cellular glass, or fibrous blow-in insulation. As an alternative, systems have been developed to attach the insulation and finish using specially designed clips and channels, eliminating the need for studs or furring strips.



Because the studs or furring strips penetrate the insulation, the properties of the stud should be considered in analyzing the wall's thermal performance. Metal stud penetrations through insulation significantly affect the thermal resistance by conducting heat from one side of the insulation to the other. Though not as conductive as metal, the thermal resistance of the wood and the cross-sectional area of the stud penetration should be taken into account.

Typically, pressure treated wood, furring strips, or metal studs are installed on the interior of the masonry and attached at the floor and ceiling. As an alternative, studs may be held away from the face of the masonry with spacers. In this case, the

insulation should be stapled or otherwise attached to the studs to prevent it from becoming dislodged. The area created by the spacers provides moisture protection, as well as a convenient and economical location for additional insulation, wiring, or pipes.

When using interior insulation, concrete masonry can accommodate both vertical and horizontal reinforcement with partial or full grouting without interrupting the insulation layer. The durability, weather resistance, and impact resistance of the exterior of a wall remains unchanged with the addition of interior insulation. Impact resistance of the interior surface is determined by the properties of the interior finish.

When interior insulation is used, some climates will require the use of an interior vapor retarder to prevent moisture migration into the insulation and subsequent condensation within the wall. Chapter 4 contains more detailed information on condensation.

### 3.3 Sound Abatement

#### 3.3.1 Sound Transmission Classification

Unwanted noise is a major distraction, both in the home as well as the work environment. Masonry walls act as barriers which block sound transmission over a wide range of frequencies. Also, the masonry wall serves to absorb the sound, further reducing the level of noise that is transmitted through the wall as shown in Figure 3-4.

One of the principal means of evaluating the level of abatement any given wall can provide against noise is by determining the sound transmission classification. The sound transmission class (STC) is a single-figure rating derived in a prescribed manner from sound transmission loss values. The

STC rating provides an estimate of the performance of the wall in specific common sound insulation scenarios.

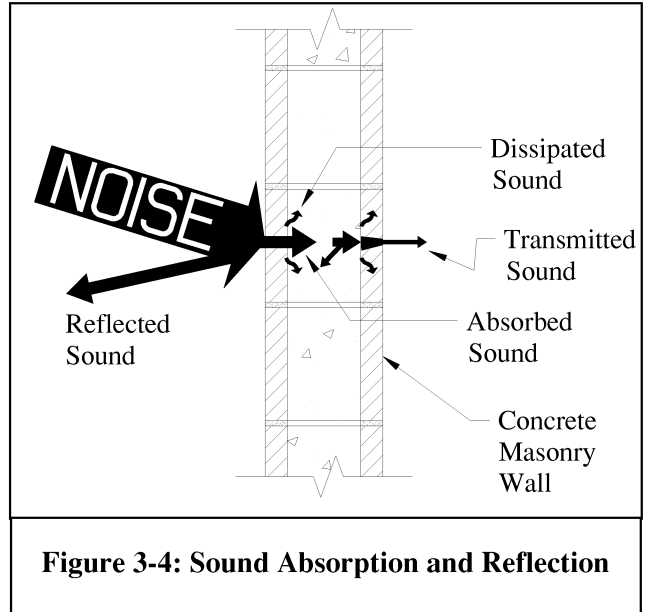
The STC for concrete masonry walls is determined using the following experimentally derived (Ref. 12E) formula.

$$STC = 0.18w + 40$$

Table 3-5 provides STC values for typical concrete masonry wall weights.

<b>Table 3-5: STC Ratings</b>	
Wall Weight (lb/ft <sup>2</sup> )	STC (dB)
20	44
30	45
40	47
50	49
60	51
70	53
80	54
90	56
100	58
110	60

The STC values of Table 3-5 are generally conservative and should be used in the absence of actual test data or other supporting evidence.



**Figure 3-4: Sound Absorption and Reflection**



# Chapter 4

## Water Penetration Resistance

### 4.1 Introduction

All below grade spaces are vulnerable to water penetration from rainfall, melting snow, irrigation, and natural groundwater – regardless of the type of material of which they are constructed. As with any design, economic considerations require that the measure(s) employed in any particular case bear some relationship to the anticipated severity of the hazard in question. Accordingly, for retaining walls and crawl space walls, water infiltration seldom creates a major problem except in climates where freeze-thaw cycles are severe or frost heave is of concern. Basement walls however must resist water penetration in order to prevent water damage to adjoining storage and habitable spaces. Hence, this Chapter focuses on below grade basement applications. To alleviate below grade water infiltration problems, the following techniques should be employed:

1. identify the potential problem;
2. follow proper construction techniques and details;
3. provide drainage to direct surface and roof water away from the basement;
4. install a subsurface drainage system to collect and direct water away from the foundation; and
5. apply damp-proofing or waterproofing systems to the masonry walls.

This Chapter reviews these primary defense techniques.

### 4.2 Identifying Potential Problems

As with any potential problem, identifying its source should always be the first course of action. This philosophy also applies to preventing water penetration into basements, once the source (or sources) of water is

identified and the potential entry points are located, steps can be taken to ensure that a basement will remain dry for the life of the structure.

#### 4.2.1 Sources of Water

Although the sources of some water or moisture problems can be apparent, some are not as obvious. Barring extraordinary occurrences such as flooding or water line ruptures, the water that typically presents a problem to subgrade living spaces stems from the following primary sources:

1. Precipitation – Precipitation can stem from several sources, including rain, melting snow, or runoff from the roof or surrounding landscape.
2. Irrigation – One may rarely consider watering the lawn, shrubs, gardens, etc. to contribute to foundation water penetration problems. However, this daily activity can be a significant source of water and should therefore always be considered.
3. Groundwater – Groundwater, water migrating towards the foundation below the ground surface, can often be a hidden problem source.
4. Condensation – Both interior and exterior air contains moisture in the form of water vapor. Under the right circumstances, this moisture can condense and accumulate on the surface or within the interior of foundation walls.

As one can imagine, it is nearly impossible to control the amount of precipitation, but one can control the runoff of precipitation with effective surface water diversion techniques. However, it is far more difficult to control the motion of groundwater (barring of course constructing dikes or

levies around one's house). Nonetheless, where groundwater may be of concern, sub-surface drainage systems have proven effective. Usually one of the easiest problems to control is the runoff from irrigation, or any problem attributed to irrigation runoff. When water penetration is attributed to irrigating sources, methods such as decreasing the amount of water, watering at more frequent intervals but for shorter times, or alternating the method of delivering the water (such as using drip lines) can be easily changed and have a significant impact on irrigation runoff.

#### 4.2.2 Potential Water Penetration

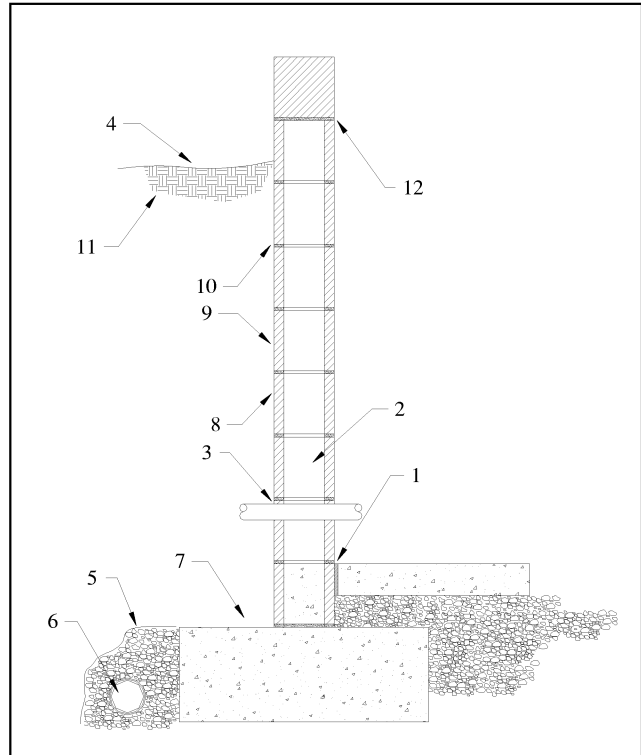
##### Locations

In addition to the water source, one must also take into consideration how the water may enter the structure. Each item should be given careful consideration prior to the onset of construction. Figure 4-1 summarizes some of the potential sources and causes of water penetration.

##### Notes to Figure 4-1

1. Water penetration through unsealed expansion joints at slab/wall interface.
2. Condensation of moisture within or on the surface of the wall.
3. Water penetration at utility penetrations.
4. Improperly sloped finish grade allows water to accumulate.
5. Missing or damaged filter material allows fine soil particles to clog perimeter drain.
6. Missing or damaged drainage system allows the accumulation of water.
7. Top of footing slopes toward wall, preventing water from draining away from foundation.
8. Cracks in foundation wall due to settlement of structure.
9. Damaged or missing water barrier.
10. Poorly filled or tooled mortar joints.

11. Poorly draining or frozen backfill does not allow water to drain away from foundation.
12. Lack of flashing or improper connection between foundation and superstructure.

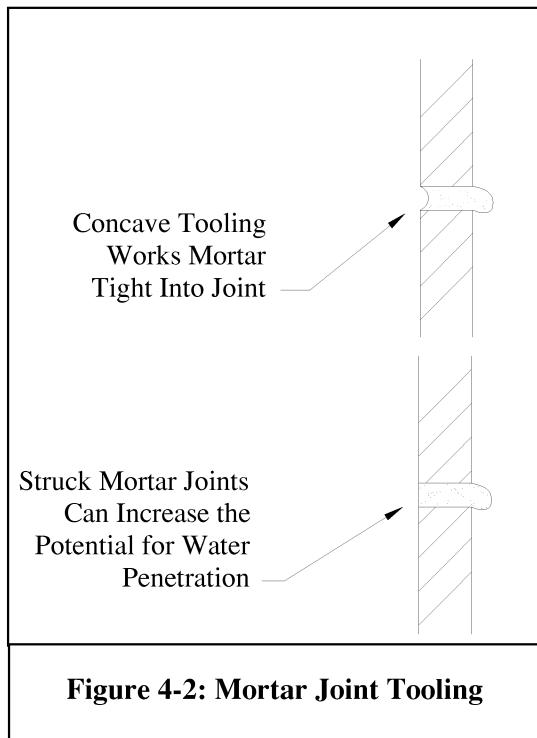


**Figure 4-1: Potential Sources of Water Infiltration**

##### 4.2.2.1 Construction Considerations

The selection of whether or not to tool mortar joints is not always as straightforward as one may expect. In above grade or exposed construction, the selection of the type of mortar joint tooling generally has an aesthetic component as well as ensuring functionality. However, in below grade and basement construction function, and not aesthetics, drives the choice of tooling (or not tooling). For the purposes of all masonry construction, tooling the mortar joints results in a compacted and reduced void mortar, thereby increasing the water penetration resistance of the masonry

assemblage. (Refer to Figure 4-2.) However, in some below grade applications, a designer or owner may opt for using a damp-proofing or waterproofing membrane. A few membranes reportedly perform better when applied over mortar joints that are struck flush with the surface of the masonry so that “bridging” over a tooled mortar joint is avoided. While for other membranes, the impact of the mortar finishing on the performance of the membrane is negligible. The manufacturers of barrier membranes should be consulted as to which mortar joint type is best suitable for their product. Regardless of the type of joint tooling chosen, the thickness of both head and bed joints should be at least as thick as the thickness of the face shell of the units.



One consideration that many new owners face during the design and construction phase is whether or not to replace poor draining backfill with a porous free draining backfill. Where native soils are naturally free draining, the need to purchase a granular backfill may be unnecessary.

However, in areas dominated by fine-grained soils (clay or silt) or high water tables, the decision to purchase a free draining backfill may be worth the added cost. Local conditions and experience are often the best guide to selecting the proper backfill material.

Although damp-proofing and waterproofing membranes can significantly increase the water penetration resistance of masonry assemblages, their performance is greatly dependent upon the care taken during the installation and backfilling processes. Unsealed seams or damage caused during construction or backfilling can render sections of the membrane useless in preventing the passage of water. Damaged membranes can potentially create more problems than if they were not installed at all as moisture that is allowed to flow between the masonry assemblage and the membrane may not have any avenue to escape other than through the wall to the interior.

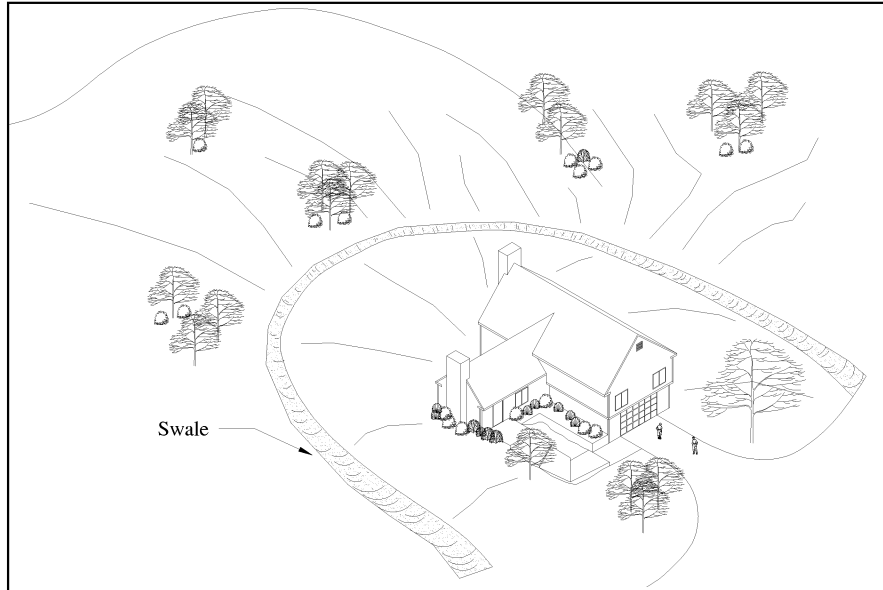
A small but important detail that can often be overlooked is the sealing of penetrations created for utilities such as water, sewer, gas, or electrical. The sealant material of choice would need to be able to withstand the hydrostatic water pressures that are anticipated. In addition, since utility penetrations are often difficult (if not impossible) to access for regular inspection or maintenance, the selected sealant should be expected to perform throughout the anticipated life of the structure.

### 4.3 Diverting Surface Water

The first line of defense in preventing moisture intrusion through a wall is to minimize the accumulation of surface water by diverting it away from the foundation. Diverting surface water may be accomplished in any of several ways. The

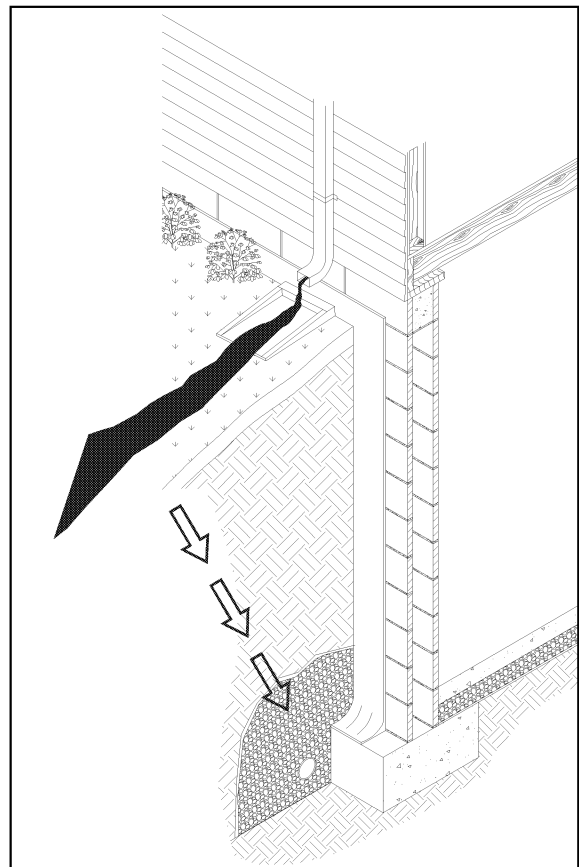


finished grade should be sloped away from the foundation at least 6 inches within 10 feet of the building. If the topography of the ground is such that the natural slope is toward the building, a shallow trench or swale can be constructed to intercept the water and divert it away from the structure as shown in Figure 4-3.



**Figure 4-3: Even With Sloping Terrain Swales Can Be Constructed To Diverted Water Away From Structures**

Gutters and downspouts should be installed to collect water from the roof of the building and deposit it away from the foundation. Water from downspouts should be directed onto splash blocks as shown in Figure 4-4 or carried away using appropriate piping. The soil directly surrounding the foundation may be protected from direct exposure to rain by the use of roof overhangs, balconies, and porches. The planting of shrubbery or the placement of a thin layer of impermeable soil over the backfill immediately adjacent to the foundation wall will further help to prevent infiltration of surface water. In any case, the discharge from downspouts should always be directed away from the foundation.



**Figure 4-4: Diverting Roof Runoff**

#### **4.4 Drainage Systems**

Regardless of wall design, soil conditions, or location, it is always good practice to minimize the accumulation of surface and groundwater adjacent to foundations. The removal of groundwater adjacent to subgrade masonry significantly helps in:

- preventing moisture penetration into an enclosed area protected by the foundation walls;

- relieving the hydrostatic pressure on the walls generated by saturated soils;
- lowering the thermal conductivity of the soil thereby creating a more comfortable living space; and
- reducing the potential damage due to frost heave of saturated soils.

The conventional method of removing water from the soil is to install a subsurface drainage system to direct water away from the foundation by gravity. Accordingly, the drains must be located lower than the space being protected. Where conditions prevent the removal of water by gravity flow, it can be directed to a sump and discharged by pumping to a higher elevation. Drainage pipes, filter fabric, drainage boards, and selectively graded soils can also be used to facilitate groundwater drainage.

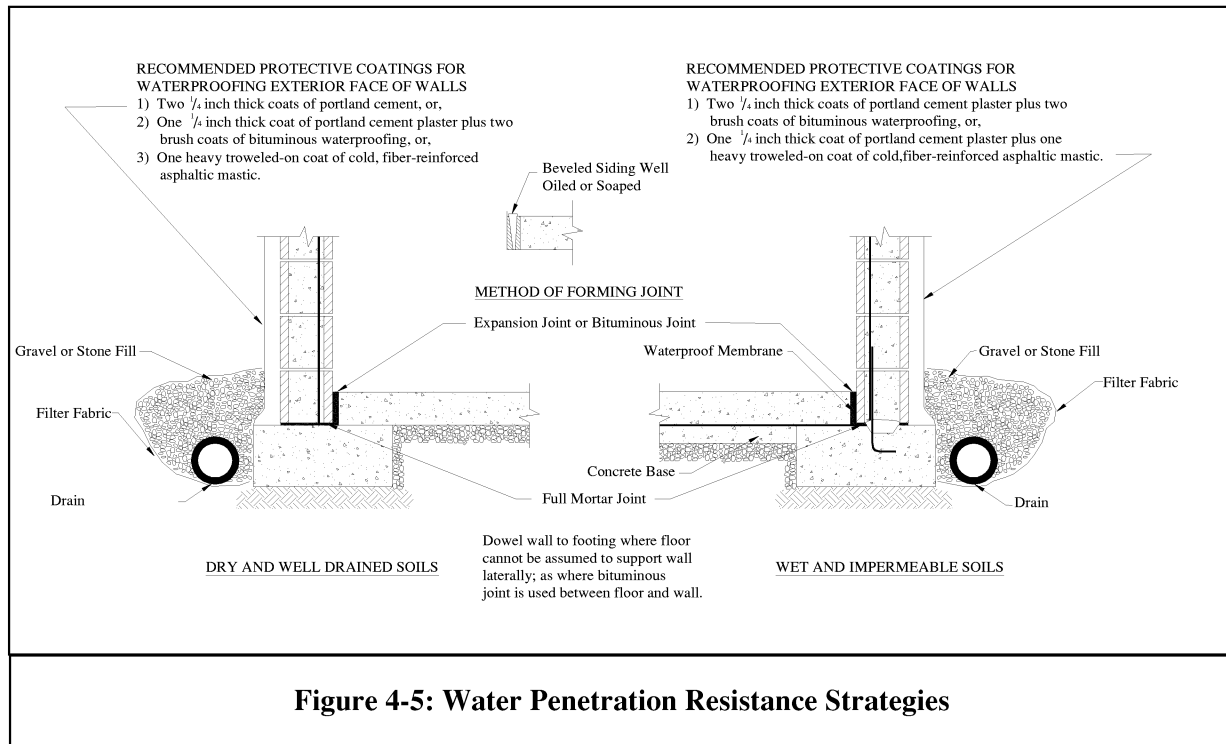
#### 4.4.1 Perimeter Drains

Perimeter drains collect water from the footing perimeter and direct it away from the foundation or to a sump or suitable discharge location. French drains, tubing, or

drain pipe are typically used with these systems.

French drains, also called channel drains, are trench systems that use coarse aggregate instead of pipe to collect and remove water. They are located immediately adjacent to the interior face of the foundation wall and below a void that separates the floor slab from the walls by a space of approximately 1 to 3 inches. The water that is collected is directed to a sump. The aggregate forces the water to take a longer and more irregular route than tubing or tile, which reduces its velocity. Therefore, French drains require greater slopes than other systems for equal performance.

In areas where elevated radon levels may be expected, a drainage system that allows the slab/wall interface to be sealed should be used in lieu of French drains. (See Chapter 7 for additional information on radon and soil gases.)



**Figure 4-5: Water Penetration Resistance Strategies**

A second option includes drainpipe systems. Typical pipe systems include perforated or slotted plastic tubing (smooth bore and corrugated) systems, although some concrete and clay drain tiles are still used. These systems consist of 4 inch or larger inside diameter plastic tubing or clay or concrete tile which is placed around the outside perimeter of the footing in such a manner that the invert is located below the top of the floor slab as shown in Figure 4-5. Perforated tubing should be placed on a 2-inch bed of washed gravel or free draining material, while tile is more effective if placed directly on the undisturbed soil where water accumulates. Tile should be placed with a gap of  $\chi$ -inch between segments to allow water to enter between the individual tiles. Both tube and tile piping systems should have a minimum slope of 4 inches in 100 feet towards the discharge. Suitable outlets include a surface drainage channel, a separate storm water sewer, a dry well, or a sump pit.

Six to twelve inches of washed gravel or free draining material should be placed over the tubing or tile and extend 12 inches or more beyond the edge of the footing. To prevent water-borne soil fines from percolating through the backfill and into the drain, filter fabrics are placed over the gravel. In the case of clay tile, an impermeable sheet such as roofing felt maybe laid over the upper half of the open joints instead of using filter fabric.

As a cautionary note, the segments of uncoupled clay tile are easily dislodged during backfilling, and the lack of continuity affords no

resistance to differential movement. Therefore, continued satisfactory performance depends on such factors as quality workmanship and field supervision. The flexibility of plastic tubing permits it to accommodate irregularities in the bedding. However, corrugated tubing is susceptible to localized movement and soft areas should be over-excavated and filled with select fill.

Drain tubing or tile can also placed on the inside of the footing as shown in Figure 4-6, either in addition to or in lieu of drains located on the outside of the footing. Experience has shown that interior drains have a failure rate only half that of exterior drains. This has been explained by the fact that the subgrade is better prepared as bedding and drainage lines located below the slab are less subject to misalignment and abuse during construction than those located under the backfill. A gravel fill should be provided at the outside of the footing, and weep holes (bleeders) installed at 8 feet on center through the footings. Where the source of water is from beneath, the tubing or tile should be installed with the openings face down. It is recommended that the



**Figure 4-6: Pipe Drainage System**

bedding gravel be at least 4 inches thick to facilitate free flow of water into the pipe.

#### **4.4.2 Free Draining Backfill**

The purpose of free draining backfill is to retain the surrounding soil while allowing water to pass through. It reduces hydrostatic pressure on the wall by facilitating the flow of water from the surrounding soil into the drain for rapid removal away from the foundation. Typical drainage materials consist of mixtures of coarse angular sand, gravel, pea gravel, crushed stone, crushed slag, and coarse-grained soils. Gradation should be such that 100% passes the 1½ inch sieve, 90-100% passes the ¾ inch sieve, and no more than 10% passes the No. 60 sieve, and the mixture is free from frozen earth, stones, vegetation, wood, and other debris. The top 4 to 8 inches of backfill should be low permeability soil so rainwater is absorbed slowly into the backfill.

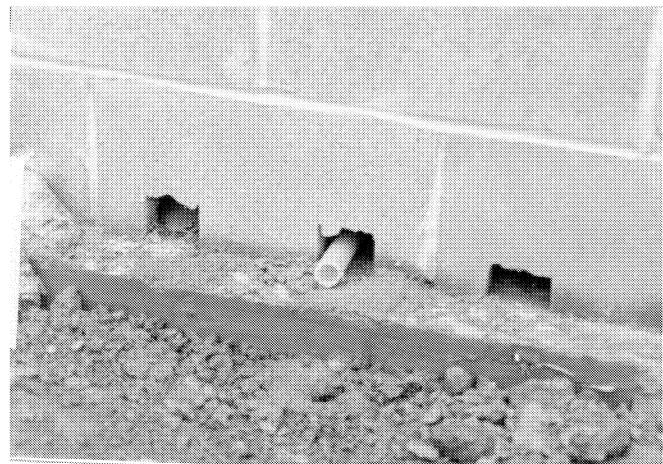
#### **4.4.3 Sump Pumps**

Where it is not possible to remove water by means of gravity flow, it may necessary to direct it to a basin (sump pit) from which it is pumped for discharge away from the foundation. Sumps are pits typically 30 inches deep by 20 inches square or 24 inches in diameter formed with plastic liners, terra cotta flue liners, or precast concrete pipe. Sumps are located beneath the basement floor slab, and are the collection point for water from the perimeter drain. When the water reaches a certain level within the sump, a float activates the sump pump, which forces the water through a drainage pipe to a location away from the foundation. Sump pits should be located several feet away from bearing walls so that the overall capacity of the foundation is not compromised. The pit should be capped and sealed, and should be accessible for inspection and maintenance.

In addition, when basements are constructed below the natural water table level, sumps are often used to remove water that accumulates under the floor slab. Refer to Section 4.6 for additional information on the removal of groundwater.

#### **4.4.4 Wall Drains**

Wall drains allow any possible moisture or condensation within the wall to enter the perimeter drain system. This is typically accomplished by providing weepholes in the masonry face shells. Where both an interior and exterior perimeter drain are installed, openings can be provided on both sides. In addition, small plastic drainage pipes can be passed through these holes and rest on the footing to connect the exterior and the subfloor drainage system as shown in Figure 4-7.



**Figure 4-7: Weep Holes At The Base Of A Foundation**

#### **4.4.5 Drainage Boards**

Drainage boards are used in conjunction with perimeter drains to relieve hydrostatic pressure against foundation walls. A variety of drainage boards are available. Dimpled plastic boards typically have a geotextile fabric bonded to the exterior surface to prevent soil from clogging the dimpled surface. Drainage boards manufactured

from expanded polystyrene beads or fiberglass provide insulation value as well as drainage. All systems allow water to drain freely either through the material or between the drainage board and the wall. Refer to Figure 4-8 for an example of a drainage board.

The drainage board should fully cover the wall and should extend to the footing. The area between the base of the board and the perimeter drain should be filled with free-draining materials so that water can be easily drained from around the footing.

Drainage boards are installed over the damp-proofing or waterproofing system, so they also serve as protection boards to ensure the water protection system is not damaged during backfilling.

#### **4.5 Damp-Proofing and Waterproofing**

Protecting below grade walls from water entry may involve installing a barrier to water and water vapor. Below grade moisture migrates from the damp soil to the drier area inside the basement. An impervious barrier on the exterior wall surface can prevent moisture entry. The barrier is part of a comprehensive system to prevent water penetration, which includes proper wall construction and the installation of drains, gutters, and proper grading.

Often, local building codes require that basement walls be damp-proofed for conditions where hydrostatic pressure does not occur, and waterproofed where hydrostatic pressure caused by a water table or saturated soils do occur. When the groundwater table can be lowered and maintained at a level not less than 6 inches below the bottom of the floor slab, damp-proofing may be used in lieu of waterproofing. (Reference Figure 4-12.)



**Figure 4-8: Drainage Board Installed On The Exterior Of A Foundation**

When choosing a waterproofing or damp-proofing system, consideration should be given to the degree of resistance necessary for hydrostatic water pressure, absorption characteristics, elasticity, stability in moist soil, resistance to mildew and algae, resistance to chemicals, appropriateness for vertical applications, freeze-thaw resistance, impact or puncture resistance, and abrasion resistance.

Waterproofing and damp-proofing systems require that the barrier be continuous to prevent water penetration into voids or open seams. Similarly, the barrier is typically carried above the finished grade level to prevent water entry between the barrier and

the foundation wall. Cracks exceeding 0.02 inches should be repaired before applying a waterproof or damp-proof barrier. However, the repair of hairline cracks is typically not required, as most barriers will either fill or span these small openings. In addition, waterproofing and damp-proofing systems should be applied to clean dry walls. In all cases, manufacturer's directions should be carefully followed for proper installation.

Particular attention should be paid to reentrant corners at garages, porches, and fireplaces and to wall penetrations. Because differential movement often occurs at these intersections, pliable membranes are often recommended at these locations to span any potential cracks.

Coatings are sprayed, trowelled, or brushed onto below-grade walls, providing a continuous barrier to water entry. Coatings should be applied to clean, structurally sound walls. Walls should be brushed or washed to remove dirt, oil, efflorescence, or other materials that may reduce the bond between the coating and the wall.

Sheet membranes and panels (drainage boards) are less dependent on workmanship and on surface preparation than coatings. Many of the membrane systems are better able to remain intact in the event of settlement or other movement of the foundation wall. All seams, terminations, and penetrations must be properly sealed.

Regardless of the type of system that is used on the below grade portion of the wall, the above grade portion of basement walls should be treated to prevent wind driven rain or groundwater from entering the foundation wall.

#### **4.5.1 Damp-proofing**

Damp-proofing is one method of providing protection against water penetration through foundation walls. Damp-proofing consists of applying water-impervious materials to prevent the passage of water vapor through the walls and to restrict the flow of liquid water under light pressure.

Some typical damp-proofing materials include: bituminous coatings, acrylic modified cement, and surface bonding mortar. When damp-proofing materials are not approved for direct application to unit masonry, the wall must be parged (coated) on the below grade exterior surface with a minimum 8-inch layer of portland cement mortar (parging).

Typical basement coatings for dry and well-drained soils as shown in Figure 4-5 consist of:

- two ¼-inch thick coats of portland cement plaster; or
- one, ¼-inch thick coat of portland cement plaster plus two brush coats of bituminous material; or
- one heavily trowelled-on coat of cold, fiber-reinforced asphaltic mastic.

A portland cement and sand mix (1:3 by volume), or Type M or S mortar may be used for the parge coat. Parging should be applied to damp (not saturated) concrete masonry. When applying two layers of a parging material, the first coat should be roughened when partially set, hardened for 24 hours, and then moistened before the second coat is applied. The second coat should be trowelled to a smooth dense surface. The parge coat should be beveled at the top to form a wash and thickened at the bottom to form a cove between the base of the wall and the top of the footing thereby directing water away from the intersection. The application of a parging material is shown in Figure 4-9.

Coal tar or asphalt based bitumens are available in solvent for hot application or in emulsions for application at ambient temperatures. These coatings can be sprayed, brushed, or trowelled onto the finish coat of parging or as a stand-alone sealant as shown in Figure 4-10.

#### **4.5.2 Waterproofing**

As stated previously, waterproofing is required where the foundation wall will be partially or fully below the groundwater table or where poorly drained or impermeable soils (clays and some silts) are present. Either condition can result in the formation of hydrostatic pressures on the exterior surface of the foundation. Waterproofing consists of coatings and sealant materials to prevent moisture from penetrating in either a vapor or liquid form. Materials used for waterproofing are generally elastic, allowing them to span small cracks and accommodate minor movements.

Typical basement coatings for wet conditions or poorly drained soils as shown in Figure 4-5 consist of:

- two ¼-inch thick coats of portland cement plaster plus two brush coats of a bituminous material; or
- one, ¼-inch thick coat of portland cement plaster plus one heavily trowelled-on coat of cold, fiber-reinforced asphaltic mastic.

Waterproofing systems also include: rubberized asphalt, polymer modified asphalt, butyl rubber, polyurethane rubber, thermoplastic sheets, 6 mil (or thicker) polyvinyl chloride, elastomeric material; and bentonite clay panels. Manufacturer's recommendations should be consulted for product limitations and proper installation requirements.



**Figure 4-9: Parging Process**

#### **4.6 Condensation**

Damp or wet basement conditions are often mistakenly attributed to leakage of water through the exterior walls, when the trouble actually may be due to condensation of moisture from the air inside the basement on the inside wall surface. Condensation in basements is most frequently encountered and troublesome in areas having a warm humid climate, but can occur wherever the temperature and relative humidity of the air in a basement is maintained at a high level – either artificially or due to atmospheric conditions. Essentially, condensation may occur at any time the wall surface temperature is below the dew point temperature of the air within the basement. Generally, the greater the indoor humidity level, the smaller the temperature

differential between the air and wall that is necessary to cause condensation.

One issue left unaddressed until now is the impact the type of construction material can have on the insulating and water resistant properties of basement walls. To illustrate this topic, take for example the scenario depicted in Figure 4-11, which demonstrates how the insulating value of an 8-inch concrete masonry basement wall compares to an 8-inch cast-in-place concrete basement wall for the same environmental conditions. Note that due to the better insulating value of the concrete masonry, the critical relative humidity level is at about 85% and 78% with the lightweight and normal weight concrete masonry wall, respectively, whereas the relative humidity necessary to cause condensation falls to about 69% with the poured concrete walls. Therefore, condensation is less likely to occur with the concrete masonry wall than with the cast-in-place concrete construction.

One method to determine if interior moisture is due to water penetration through the wall or can be attributed to condensation is to tape a piece of clean plastic onto the interior surface of the foundation wall. If moisture collects between the plastic and the wall surface, water penetration is the cause. If condensation is occurring, moisture will be visible on the exterior surface of the plastic.

Condensation will occur on any surface where the surface temperature is at or below the dew point temperature of the air. The dew point varies with the dry bulb temperature and the relative humidity and can be determined from a psychrometric chart. But in general, one can remember that the higher the relative humidity, the closer the dew point temperature is to the dry bulb temperature and hence, the more likely condensation is to occur at high



**Figure 4-10: Applying Exterior Bituminous Sealant**

relative humidity levels. In below grade walls, condensation is most likely to occur in the spring and early summer, when the earth is still cool due to the thermal lag of the soil, but the dew point temperature of the air is relatively high.

Condensation within the wall can lead to a loss of effectiveness or degradation of some thermal insulation or, in some cases, to mildew growth. However, the possibility of condensation can be minimized with appropriate design.

There are three basic approaches to preventing condensation: keep the wall temperature above the dew point temperature of the air, prevent moist indoor air from contacting the cooler wall, or lower the indoor relative humidity using a dehumidifier.



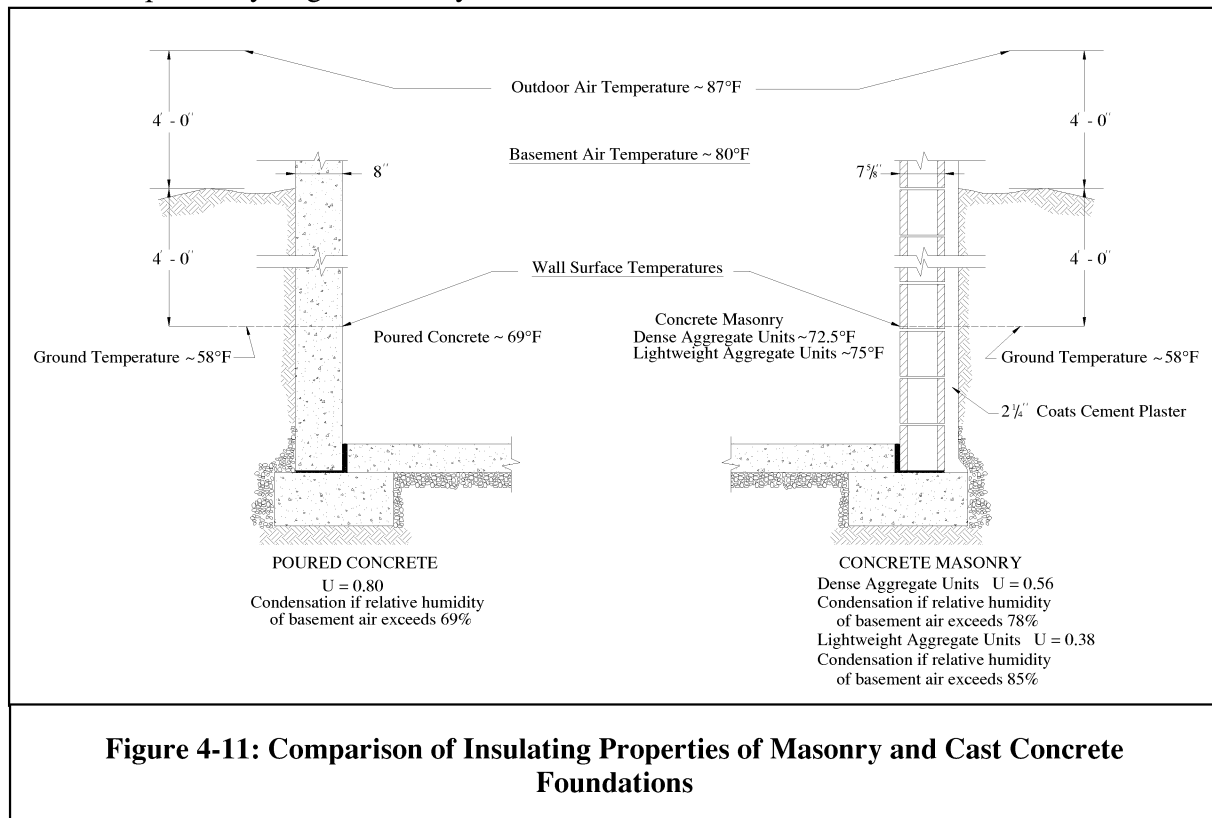
Exterior insulation can prevent condensation by isolating the wall from the soil temperature. This keeps the wall temperature closer to the indoor air temperature and above the indoor air dew point temperature.

With interior insulation, the foundation wall temperature is closer to the soil temperature, raising the possibility of condensation within the insulation layer. In this case, installing a vapor retarder on the interior side of the insulation prevents condensation. With integral insulation, a vapor retarder may be installed on the interior wall surface to prevent condensation within the wall. However, if the bottom of the wall and the foundation perimeter are properly drained, condensation will not be allowed to build up within a wall.

When raised floor construction with crawl spaces is used, the air within these spaces can develop a very high humidity due to

improperly drained groundwater. These high moisture levels and condensation can lead to degradation of wood elements. Proper drainage and grading will help prevent this problem, as will the use of a ground cover. A ground cover consisting of 6-mil polyethylene, 45 mil smooth roll roofing, or similar material will restrict water evaporation from the soil into the crawl space. Any ducts in the crawl space should be carefully sealed since heat will increase the evaporation of moisture from the soil. Any ducts from clothes dryer should be vented elsewhere as its discharge contains very hot, humid air.

The benefit of venting the crawl space to the outdoors has been investigated in recent years. Although many codes require crawl space ventilation, there is no compelling technical basis for these ventilation requirements.



Care should be taken when ventilating conditioned crawl spaces with indoor air, which have insulated walls and may contain heating or plumbing runs, due to the increased potential for soil gas infiltration. Unconditioned crawl spaces should have a ground cover, as described above, if they are not vented with outside air.

#### 4.7 Groundwater Drainage

In circumstances where basements are located a small distance (up to a few feet depending on the properties of the native soil) below the water table, it is often necessary to take added precautions to prevent the buildup of large hydrostatic pressures. This may often require the use of several of the topics previously discussed in this chapter.

When the bottom of a basement is located below the water table, hydrostatic pressures develop as a result of the groundwater. These pressures act both laterally against the foundation wall and vertically against the basement floor slab – causing the slab to “float” and water seepage to occur. To alleviate these forms of hydrostatic pressure, a perimeter drainage system is installed to draw the water table down and a sump pit constructed to collect and discharge any water that accumulates under the floor slab as shown in Figure 4-12. Where there is a concern of the ability of the exterior drainage system to collect all the anticipated groundwater, an interior drainage system (i.e., a French drain) may also be constructed. All water collected through these means must be discharged either by pump or gravity to an appropriate site as discussed above.

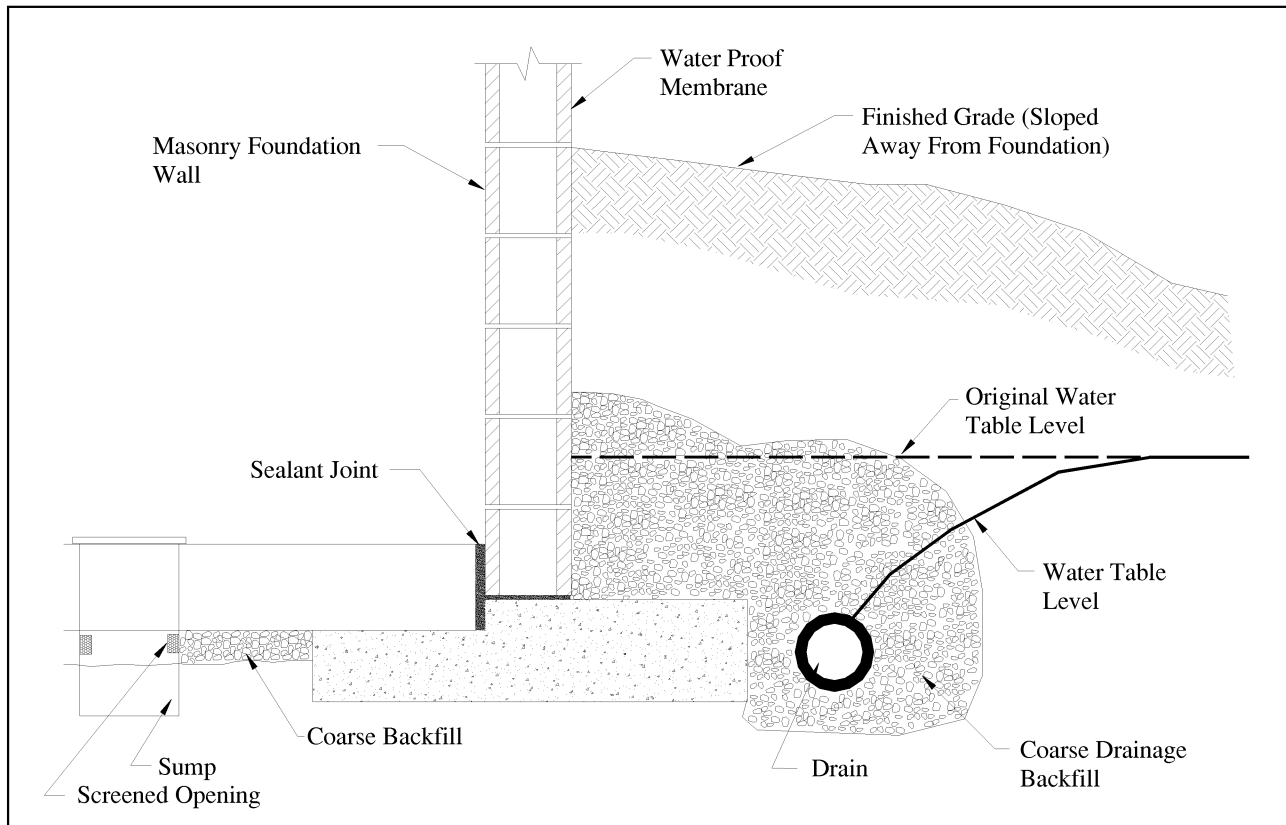
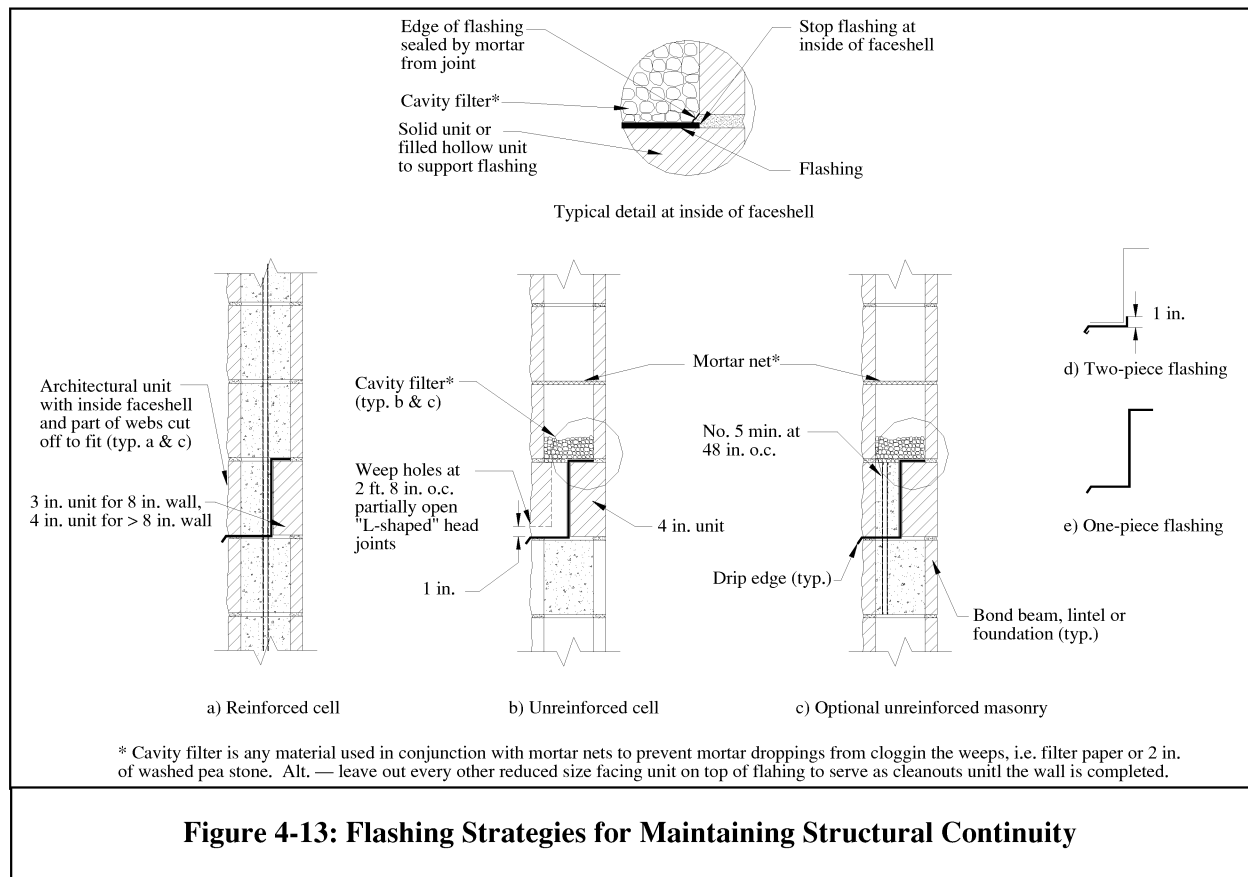


Figure 4-12: Lowering Water Table

## 4.8 Flashing

An important aspect of maintaining a dry basement is the proper placement of flashing and weepholes in the above grade walls. In many circumstances, it is aesthetically or economically unfeasible to totally prevent moisture from entering above grade masonry walls. This water, if not intercepted, will migrate downward through the above grade wall into the foundation wall where it may penetrate to the interior. Flashing is used to divert the water that manages to penetrate the above grade walls to the exterior. While it should be located over all wall openings and under windowsills, flashing is especially important above the first course of block over the top of the foundation. In order to prevent the flashing from forming a bond break at this location, the first course of block should be composed of two units in such a manner that the flashing extends beneath the outer unit

and is bent upward and inward to cover the top of the inside unit, but does not go through the mortar joint of the interior face shell. Since the purpose of flashing is to intercept moisture and direct it to the outside, weepholes must be provided wherever flashing is installed. Weepholes may be formed of plastic tubing, wicks, or the elimination of a portion of the head joint. When openings in the head joint or plastic tubing are used (Refer to Figure 4-7.), weepholes should be spaced 24 to 32 inches on center. When wick material is used, the weepholes should be placed at a maximum of 16 inches on center.



# Chapter 5

## Crack Control

### 5.1 Introduction

For all forms of construction, cracking in buildings and building materials has several potential causes. Due to the numerous sources of cracks, the control of cracking requires careful consideration and design. The key to crack control is in understanding the cause of potential cracking, thereby allowing a designer to incorporate appropriate design procedures. While proper structural design methods are discussed in detail in Chapter 2, this Chapter focuses on methods to reduce the potential for cracking, which may be aesthetically displeasing or degrade the performance or serviceability of the masonry.

### 5.2 Sources of Potential Cracks

As stated, cracking in concrete masonry can stem from several potential sources, including:

- Restrained shrinkage – When concrete masonry panels are restrained from moving, cracks can develop due to shrinkage as a result of the drying of the masonry units, temperature fluctuations, and/or carbonation of the cementitious materials.
- Differential movement – Various building materials may react differently to changes in temperature, moisture, or structural loading. When materials with differing properties are combined into a structural system, a potential exists for cracking due to differential movement. This is particularly true with two materials commonly used with concrete masonry: clay brick and structural steel.
- Excessive deflection – As walls and beams deflect under structural loads, cracking may occur. Additionally,

deflection of supporting members having different properties compared to the masonry they are supporting can induce cracks in masonry elements.

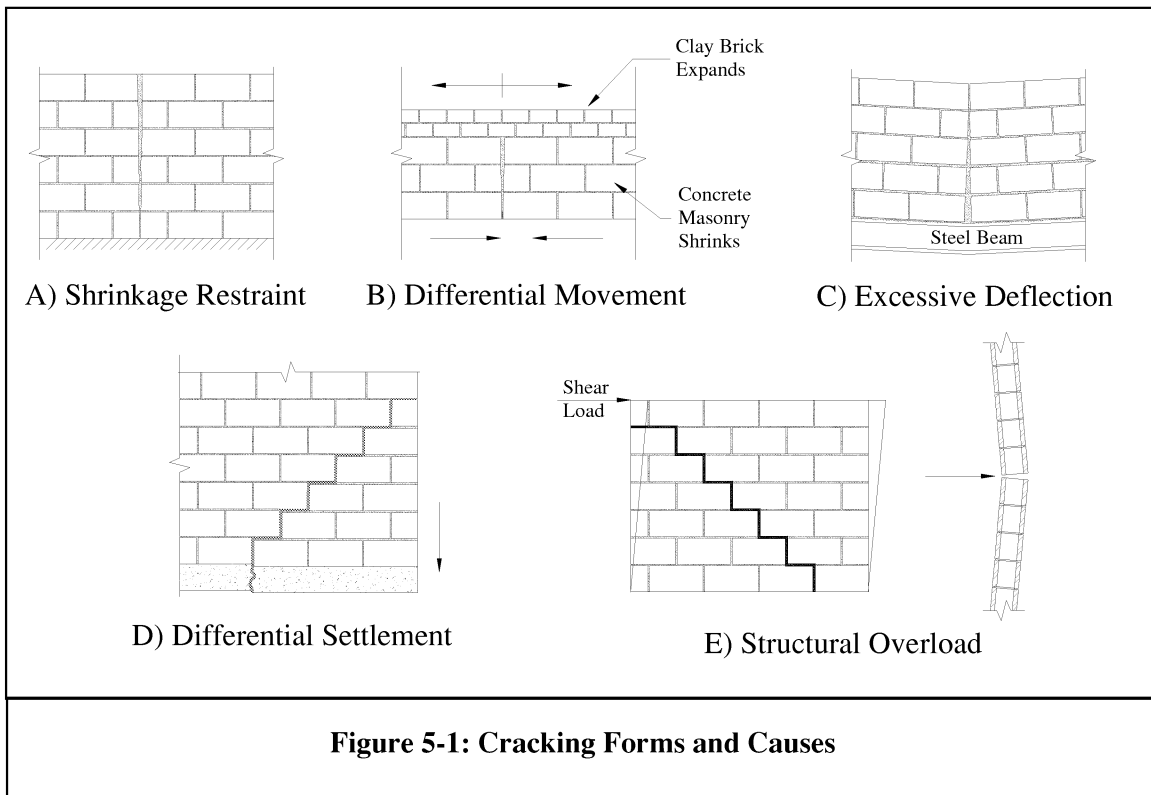
- Differential settlement – Differential settlement occurs when portions of the supporting foundation subside due to weak or improperly compacted foundation soils. Preventing settlement cracking depends on a realistic evaluation of soil bearing capacity and on proper footing design and construction.
- Structural overload – All wall systems are subject to potential cracking from applied loads resulting from dead or live loads, wind, soil pressure, or seismic forces. Applying the appropriate design criteria controls cracking due to these sources.

Figure 5-1 details these forms of cracking. In most cases, movement of building materials is inevitable and must be accommodated, controlled, or otherwise accounted for in order to minimize cracking.

### 5.3 Accommodating Movement

#### 5.3.1 Controlling Shrinkage

Concrete masonry is subject to expansion and contraction with changes in moisture content and ambient temperature as well as shrinkage due to the chemical reaction of the cementitious materials with the carbon dioxide in the air, called carbonation. Of these two, contraction requires design consideration, since concrete tends to shrink more than it expands over time. (This is further compounded by the relatively weak tensile strength of plain concrete masonry with respect to its compressive strength.) Shrinkage of concrete masonry walls is best



controlled by laying relatively dry units and protecting unfinished walls from rain and other moisture sources, by using horizontal steel to increase tensile resistance to shrinkage cracking, and, for some foundation walls, by incorporating control joints to allow wall movement.

#### 5.3.1.1 Control Joints

One of the most common design considerations used in the prevention of shrinkage cracks is the incorporation of control joints into the construction. Control joints are vertical separations built into the wall at locations where cracking is expected. They reduce restraint and accommodate movement within the plane of the masonry wall.

*However, it is normally not necessary to provide control joints in below grade residential concrete masonry basement walls.* The lack of necessary control joints is attributed to the relatively low range of

thermal and moisture fluctuations occurring in below grade walls as a result of the temperature moderation afforded by the soil adjacent to the walls and to the water resistant systems applied to basement walls, respectively. In most below grade basement wall construction, it is possible to provide a reinforced bond beam at, or near the top of the wall in lieu of control joints to minimize crack development. Where it is imperative that control joints be used in below-grade construction, special attention should be given to their design to insure maximum protection against moisture infiltration and structural continuity of the wall.

For very long walls or foundation walls partially or completely above grade, control joints may be used either in conjunction with, or instead of, horizontal reinforcement to control shrinkage cracking. Where horizontal reinforcement or reinforced bond beams are incorporated solely for crack control, the reinforcing steel should be discontinuous at existing control joints to

allow unrestrained movement. The one exception to this is for the bond beams located at floor and roof levels. Such elements serve a structural purpose of tying a wall together and therefore must contain continuous reinforcement. Additionally, this will also minimize the possibility that movement at the control joints will cause cracking of interior finishes in the superstructure.

When below grade control joints are used, they should be keyed or doweled to transfer shear across the joints to resist the anticipated lateral earth pressures as shown in Figure 5-2. Additionally, careful attention must be placed on sealing control joints to prevent the intrusion of water.

Furthermore, when the above grade construction is of masonry and contains control joints, movement at the above grade joints may cause cracking in the masonry foundation wall below. To minimize this possibility, it is recommended that a continuous bond beam be provided at the top of the foundation wall and that the control joints in the above grade walls be

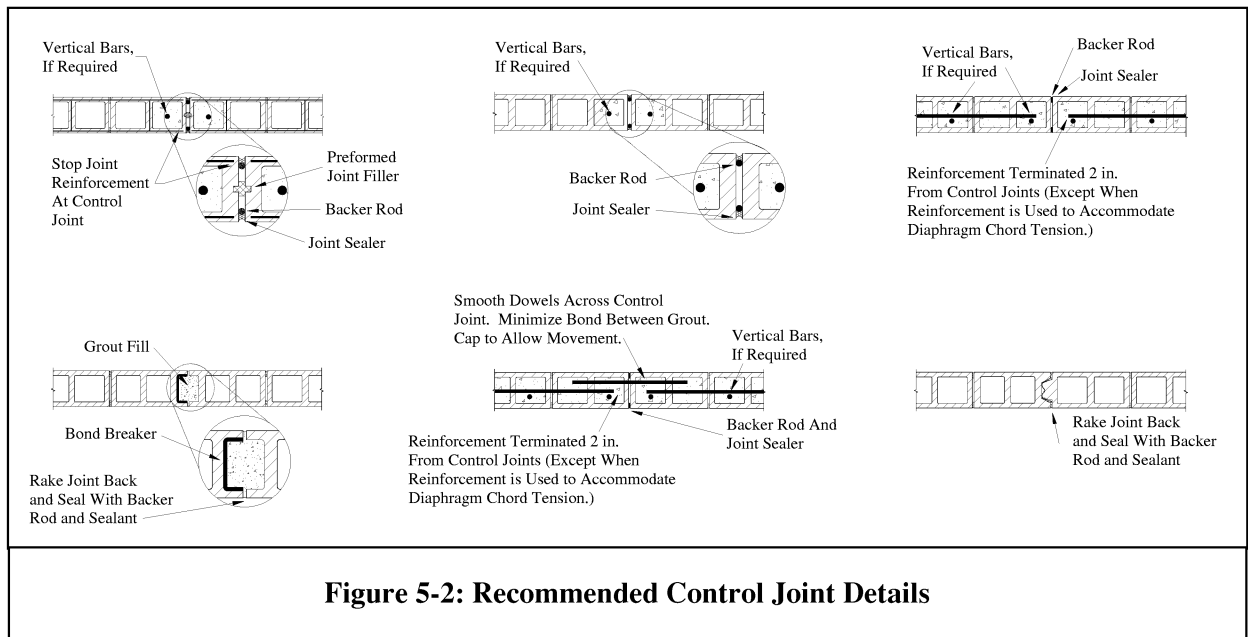
terminated at the bond beam as detailed in Figure 5-3.

Reference 12A details the spacing and location of control joints depending on the construction materials used, type of construction, and presence of horizontal reinforcement. As a general rule of thumb, the spacing of control joints should not exceed 1.5 times the height of the wall nor 25 feet.

### 5.3.1.2 Horizontal Reinforcement

Horizontal reinforcement increases the tensile strength of a concrete masonry wall in the direction of the reinforcement and minimizes the formation of large shrinkage cracks. Horizontal reinforcement may be incorporated into concrete masonry walls as horizontal joint reinforcement, bond beam reinforcement, or both with or without the inclusion of control joints – depending on the anticipated shrinkage and design application.

Bond beams are horizontal structural elements that integrate the components of a wall into a structural unit. As a means of



crack control, bond beams are capable of resisting horizontal movement in an area 24 inches above and below the location of the reinforcement. For this reason, bond beams spaced at 48 inches on center can serve as a crack control measure for the entire wall. As an alternative, bond beams may be spaced as far apart as 12 foot providing bed joint reinforcement is incorporated at specified intervals. Where horizontal reinforcement is the sole source of crack control, the area of horizontal steel should equal 0.2% of the net cross-sectional area of the masonry. (Ref. 12A)

Bond beams are constructed of special units capable of receiving horizontal reinforcing bars and grout. Where vertical steel is incorporated into a wall, bond beam units should be capable of accommodating both horizontal and vertical reinforcement.

Joint reinforcement may be embedded in masonry bed joints, usually at 16 inches on center, to provide crack control throughout the wall. Cold drawn wire for masonry joint reinforcement varies in size from W1.1 (11 gauge) to W4.9 (¼ inch). However the practical limit for wire diameter is  $\frac{3}{16}$ -inch since current codes limit the diameter of wire to one-half of the mortar joint thickness. Further, due to code-imposed construction tolerances and cover requirements, W 1.7 (9-gage) wire is the most commonly used joint reinforcement.

### 5.3.1.3 Construction Practices

Because drying shrinkage is a primary cause of cracking in concrete masonry walls, it is important to minimize the potential for wetting concrete masonry during the construction process. At the

jobsite, concrete block should be stored so as to protect the units from absorbing ground water or precipitation. This includes storing block on pallets (or otherwise isolating block from direct contact with the ground) and covering the units with plastic or other water repellent materials.

Concrete masonry units should be relatively dry when laid. Some surface moisture is acceptable, however saturated units should be allowed to dry out before placement in the wall. Concrete masonry units should never be wetted before or during placement in the wall, as may be customary with clay masonry units.

At the end of each workday, a weatherproof membrane should be placed over uncompleted walls to protect the units from rain or snow. Placing a board on top of the membrane will help hold it in place and will prevent the membrane from sagging into the masonry cores and allowing water to collect.

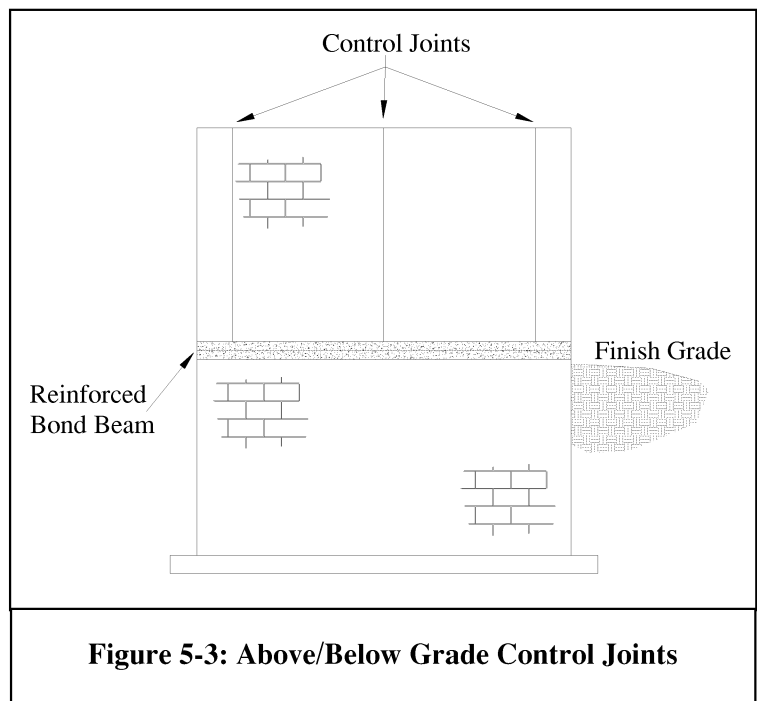


Figure 5-3: Above/Below Grade Control Joints

### ***5.3.2 Controlling Differential Movement***

A joint is typically left between the slab and adjacent concrete masonry foundation walls to accommodate movement of the slab without affecting the foundation walls. (Refer to Figure 4-5.) Where isolation joints are necessary between the concrete slab and the foundation wall, sufficient spacing should be provided to allow anticipated movement. A bond break between the slab and the foundation can be formed using building paper or a portion of the underlayment. The building paper breaks the bond between the newly placed slab and the wall, yet still allows the slab to assist in supporting basement walls subjected to lateral soil loads. The joint may also be formed using joint fillers and sealants. Where termite or soil gas resistance is a concern, or for wet or impervious soils, the joint should be sealed with a flexible sealant to allow movement, but prevent gas or water infiltration.

### ***5.3.3 Controlling Excessive Deflection***

In all design situations, masonry is supported in one fashion or another by another material – whether it is the masonry spanning an opening supported by a lintel or masonry bearing directly on a footing, which in turn is supported by the soil. Since in foundation walls the wall is continuously supported, excessive deflection is seldom of concern with a properly compacted free-draining soil.

### ***5.3.4 Controlling Differential Settlement***

Unequal settlement of continuous footings resting on poor bearing soil can induce cracks in the masonry foundation walls above. Ideally, footings for concrete masonry foundation walls should be placed on undisturbed soil to minimize potential settlement. To help prevent settlement and subsequent cracking, footings should be

placed on undisturbed native soil, unless this soil is unsuitable, weak, or soft. Unsuitable soil should be removed and replaced with compacted soil, gravel, or concrete. In addition, longitudinal steel in the footing increases the footing's capacity to bridge local weak spots. More information on placement of concrete footings is included in Chapter 8.

### ***5.3.5 Controlling Structural Overload***

While structural overload can have many sources, for below grade foundation walls in conventional residential construction, the axial loads stemming from the superstructure rarely are sufficient to cause structural overload and cracking. However, below grade foundation walls are susceptible to unanticipated lateral loads, the most common of which are discussed herein.

Clay soils, in addition to being difficult or impractical to drain, substantially increase in volume once saturated. This significant increase in volume places an added lateral load to foundation walls. To avoid this problem associated with clay soils, over-excavate around the foundation wall and backfill with a free draining soil.

Additionally, if a backfill soil is not well drained or if the foundation wall is below the natural water table, hydrostatic pressure can act on the foundation. The best protection against this is to provide adequate drainage of both surface water and subsurface water. However, if all or a portion of the foundation is below the water table, special design precautions must be accounted for as detailed in Chapter 4. An added problem associated with saturated soils adjacent to a foundation wall is frost heave. When the water in the soil freezes, it increases in volume and exerts pressure on the foundation. Again, the best method to



alleviate this problem is to ensure adequate drainage of water. Methods to accomplish this are discussed in detail in Chapter 4.

## Chapter 6

### Insect Protection

#### 6.1 Introduction

Termites are found widely throughout the United States and cause substantial damage to unprotected wood buildings. Although there are over forty species of termites in the United States alone (over 2,500 species around the world), most termite damage is attributed to subterranean termites. This chapter focuses on measures to reduce the possibility of subterranean termite entry into a building.

While termites do not cause any damage to masonry materials, they do feed on any products containing cellulose, most notably wood. Buildings that do not use wood or cellulose products as a construction material are not prone to termite infestation. Naturally, when wood is used as a construction material, the further the food source is from the soil, the less likely the termite infestation.

Subterranean termites nest in the ground because they require a moist humid environment to survive. Entry into a building must be gained through a sheltered path, such as a crack in a foundation wall or slab. If a sheltered path to the food source is not available, it is possible for termites to build their own access tunnels, which protect them from sunlight and open air. Often, these access tunnels can be the only direct sign of a termite infestation.

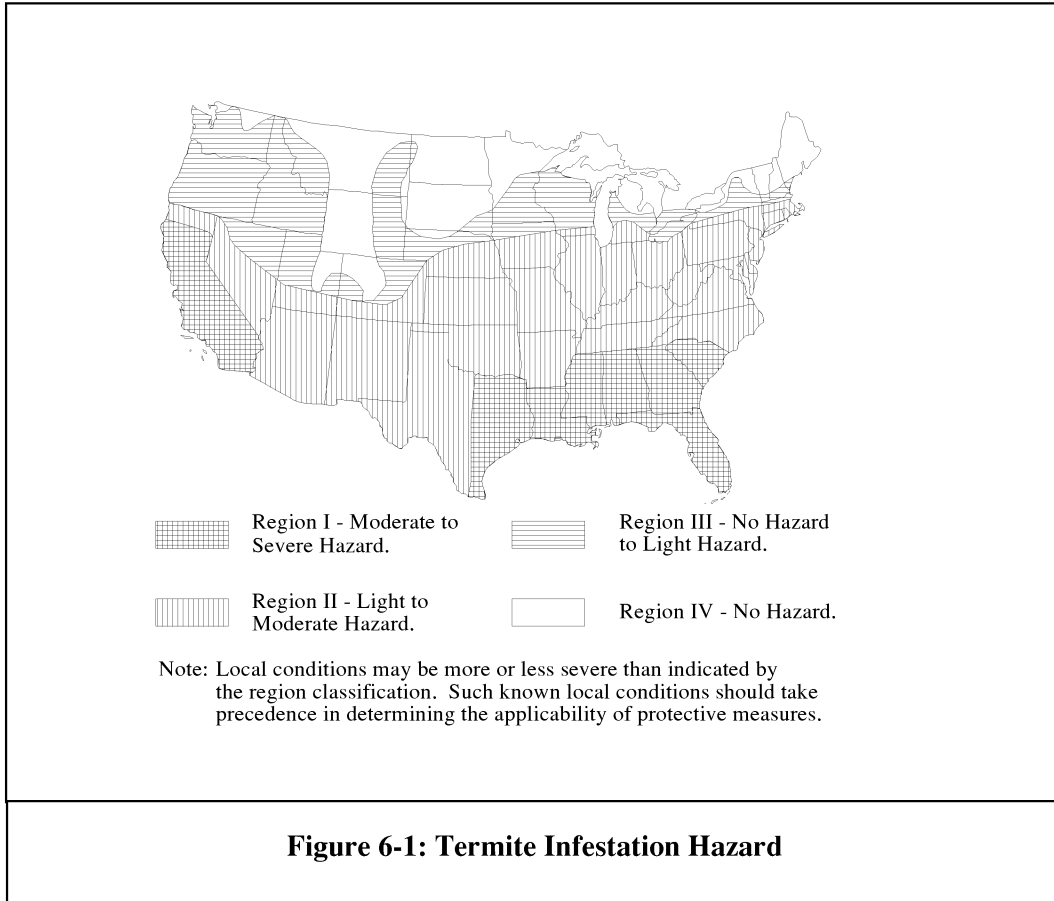
It is important to consider the potential for termite infestation during the construction phase, since the building construction practices themselves can help protect against future infestation. Many of these measures focus on proper design and quality construction to reduce possible entry routes

and to provide a hostile (dry) environment to ward off termites. These same methods may already be employed for protection from water penetration or soil gas entry.

Strategies for termite control include:

- minimizing cracks in walls and slabs;
- sealing around all wall and floor penetrations;
- keeping the foundation and adjacent soil dry;
- providing for access to inspect for termite tunnels;
- installing barriers to prevent termite entry;
- maintaining a minimum clearance between wood members and soil;
- treating soil with chemicals to repel termites; and
- utilizing termite resistant construction materials.

The level of termite control employed on a particular job should be consistent with the expected severity of the termite hazard. This level of severity for a particular location can be determined from local experience or from the state entomological authorities. Where such information is not available, Figure 6-1 may serve as a guide.



## 6.2 Site Conditions

While preparing the site prior to construction, all roots, stumps, dead timber, and other wood debris should be removed from the site. Similarly, wood scraps from construction should be properly disposed. Leaving this material on site or in the backfill provides additional food sources for termites and increases the likelihood of infestation. Similarly, wood grade stakes or bracing stakes should be removed before or during concrete placement and not cast into the concrete. Leaving them in place provides a direct path for the termites through the concrete. Refer to Figure 6-2 for a summary of critical termite access areas.

As described in Chapter 4, backfilling with a free draining soil, incorporating a subgrade drainage system, and proper above grade water drainage will help keep the foundation and adjacent soil dry. Providing a less hospitable environment for termites starts with a dry soil.

In extreme circumstances, subterranean termites may not require constant access to and from the adjacent soil. Where conditions exist such that wood remains continuously saturated, termites are not required to return to the soil to obtain water. For this reason, structures should be designed and maintained to minimize water intrusion. However, such conditions are extreme and not generally considered during design.

*Notes to Figure 6-2*

1. Ensure that the soil directly adjacent to the foundation is dry and free of scrap lumber or decaying wood.
2. All utility penetrations through foundation walls should be sealed for both termite and water penetration resistance.
3. Remove any dead or decaying wood from the area. All trees and plants should be healthy.
4. Any wood in direct contact with the ground should be rated for such use. Non-treated wood provides a direct path for termite passage.
5. Inspect the foundation monthly for signs of termite activity or the development of cracks.

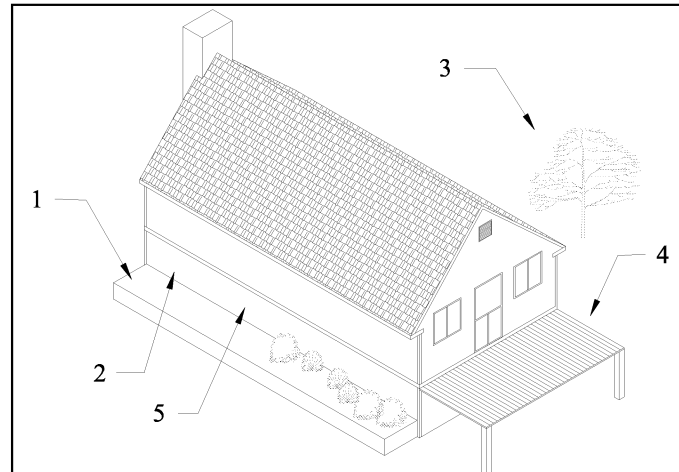
### 6.3 Reducing Entry Routes

Once the termites have established a path, they can have free roam of all connecting elements of the structure. Therefore, keeping termites out of the structure should always be the paramount objective. In addition to the obvious points of entry (such as wood in direct contact with the soil), other obscure (but critical) termite entry routes include:

- through cracks in exposed wall faces or slabs (termites are capable of moving through a crack only  $1/32$ -inch wide);
- direct access from soil under porches or patio slabs;
- along the outside of pipes penetrating slabs or foundation walls; and
- access tunnels on the interior of walls or exterior above grade walls.

#### 6.3.1 Minimizing Cracks

Proper structural design of foundation walls, footings, and slabs will help prevent structural cracking that may allow termite entry. Refer to Chapter 2 for details on proper structural design considerations.



**Figure 6-2: Key Termite Protection Locations**

In addition to preventing cracks due to structural overload, cracking due to concrete shrinkage also needs to be addressed. Due to fluctuations in the temperature and moisture content, all materials have a tendency to expand and contract over time. With concrete masonry foundations, the primary concern focuses on shrinkage resulting in the development of tensile stresses. This is because the tensile strength of concrete is relatively small compared to the compressive strength; therefore shrinkage may result in small cracks within the masonry. Measures to reduce the shrinkage cracking potential of concrete masonry are detailed in Chapter 5. The recommendations of the American Concrete Institute (Ref. 2) for quality concrete placement should be followed to limit slab cracking.

In terms of preventing termite entry, these measures become more important in crawl space and stem walls, which are typically not treated on the exterior to prevent water entry. In these cases, termites can enter the block through small cracks and move unseen up ungrouted cores. Basement walls on the other hand are often damp-proofed or

waterproofed to reduce water penetration. Precautions such as these also provide an added level of termite protection. As discussed in Chapter 4 however, proper design and construction is necessary to maintain the integrity of the water-resistant system.

### 6.3.2 Minimum Clearance to Soil

It is desirable to keep wood elements as far as possible from the soil to minimize termite access. Nonstructural wood elements, such as wood siding and trim, should be kept a minimum of 6 inches from the soil surface. Structural wood framing, sill plates, and sheathing should be kept at least 8 inches above the soil, or as otherwise required by local building codes. However, if the nonstructural wood is in contact with the structural wood (which is generally the case), the 6-inch minimum clearance should be increased to 8 inches. These general clearances do not apply to pressure-treated wood or other termite and decay resistant woods.

### 6.3.3 Capping Concrete Masonry Walls

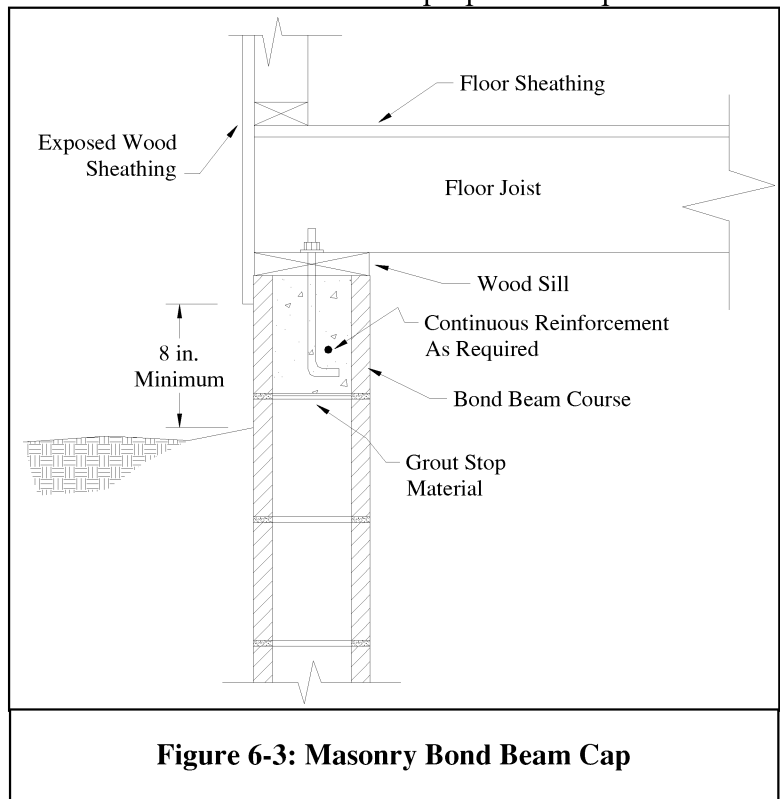
Various methods are used to seal the tops of masonry foundation walls. Should termites penetrate the face shell of a concrete masonry wall, the cap prevents them from direct access to the wood superstructure, if present. In reinforced construction, the masonry bond beam at the top of the wall serves as an effective cap as shown in Figure 6-3.

Metal termite shields may be installed as a continuous barrier directly below the sill plate. If infestation occurs, termites are forced to build conspicuous

access tunnels around the shield, making detection easy. Because termites require only a  $\frac{1}{32}$ -inch gap for penetration, termite shields must be installed with great care to be effective. All seams must be soldered and all openings around anchor bolts and service lead-ins must be sealed. Because of the extreme care required to provide an impenetrable metal termite shield, they generally are not relied upon for termite protection.

### 6.3.4 Exterior Insulation

The rigid plastic foams that are often used to insulate basement and crawl space walls can allow termites to create undetectable tunnels. An advantage of concrete masonry foundation walls is their ability to accommodate insulation within the cores of the masonry units where it is protected from direct contact with the soil. Either rigid foam insulation inserts, granular fill insulation, or foamed-in-place insulation can be used for this purpose. Chapter 3 contains



more detailed information on installing insulation in concrete masonry cores.

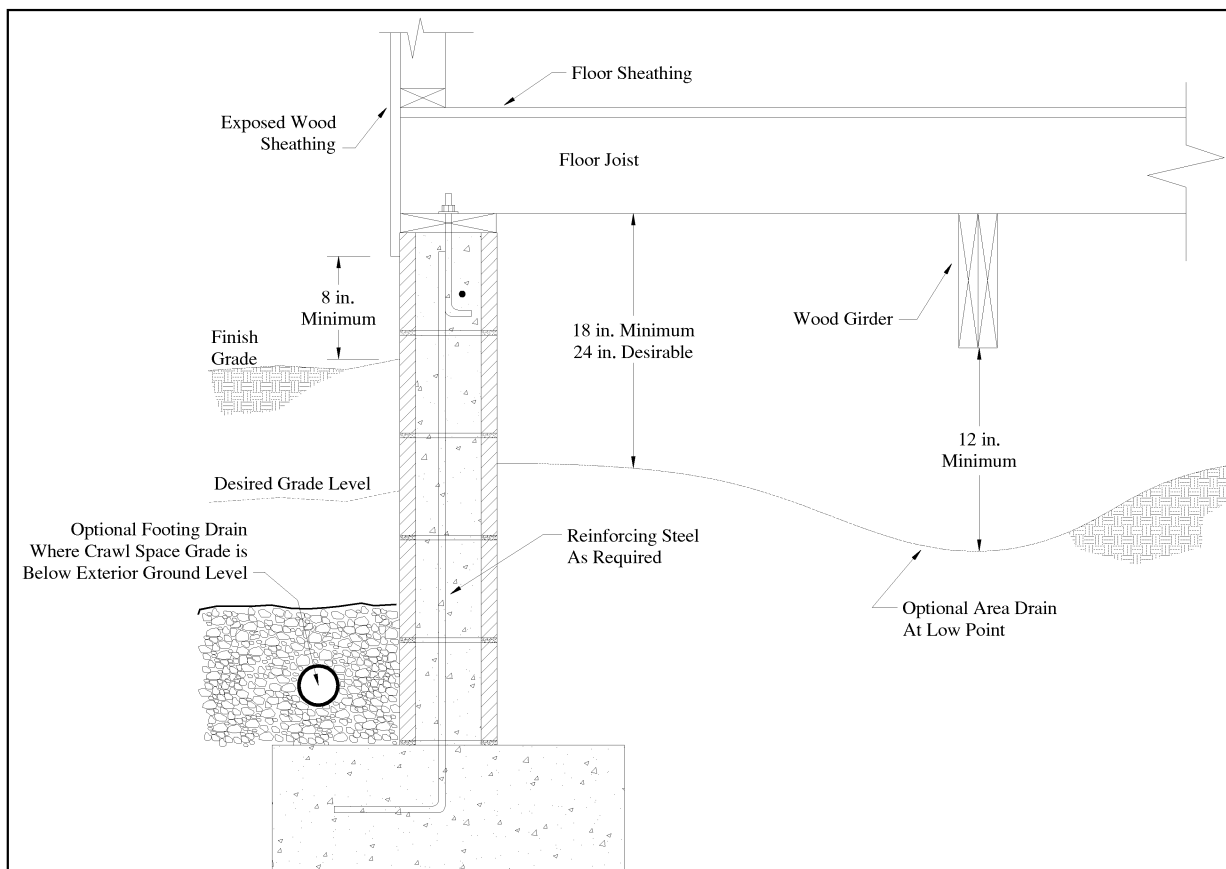
### 6.3.5 Additional Considerations for Crawl Spaces

Figure 6-4 illustrates termite control measures for crawl space foundations. Crawl space floors should be kept at or above the exterior finished grade to facilitate drainage in the crawl space. Where this is not possible, or on sites where water flows toward the building due to the site slope, area drains should be installed. Unless specified otherwise by local codes, wood girders should be at least 12 inches above the crawl space floor, and wood joists should be no closer than 18 inches. In all cases, enough clearance should be

maintained to allow access to the crawl space for inspection.

### 6.4 Chemical Treatments

Numerous methods are available to allow creating a pesticide barrier within the soil adjacent to a structure that termites have difficulty penetrating. The treatment of the soil before or during construction is often most effective as there is better access to the subgrade soil. If a slab-on-grade is also going to be used, the soil under the slab can also be pretreated. While post-construction treatment is far more common, it is also more difficult. Limited access to some areas may not allow for an effective chemical barrier to be established.



**Figure 6-4: Termite Control Measures for Crawl Space Foundations**



# Chapter 7

## Soil Gas Resistance

### 7.1 Introduction

Although gases originating within the soil can have numerous forms and sources, this chapter focuses primarily on radon gas. (However, the considerations outlined herein also generally apply to other soil gases.) Radon is an inert radioactive element that is released from the Earth's crust as an invisible odorless gas. Although there are different kinds, the radon that occurs most readily in the environment results from the decay of uranium. The ambient level of radon in outdoor air is currently not thought to pose a significant health hazard. However, when radon enters buildings, it can accumulate over time and reach higher levels than exist outdoors.

Soil radon levels vary by location, and can be different at sites as close as a few hundred feet apart. Factors that contribute to the volume of radon released from the Earth include the type of the underlying rock structure, the relative porosity of the soil, soil moisture, and soil depth.

This chapter provides a brief summary of available current information, knowledge, and practice regarding radon mitigation in new concrete masonry basement construction. A more complete discussion is available in *Building Radon Resistant Foundations, A Design Handbook* (Ref. 1). Most data has been obtained from tests conducted on one and two-family residential structures. However, many of the recommendations contained herein for reducing radon entry are generally considered to be appropriate for all structures.

### 7.2 Site Evaluation

As one would imagine, there are currently no practical testing methods for determining indoor radon concentrations prior to construction. As an alternative, the U.S. Environmental Protection Agency (Ref. 3) lists the following questions and considerations in connection with site evaluation:

- Have existing homes in the same geological area experienced elevated radon levels? Sources of information include: regional Environmental Protection Agency offices, state environmental offices, local health departments, or radiation protection offices.
- What are the general characteristics of the soil? Is it derived from underlying rock such as granite, black shale, or phosphate bearing ore? (Such rock normally contains above average concentrations of uranium or thorium – the source of radon.) Is the rock structure stable or fractured? (Fractured rock allows larger quantities of radon to pass quickly through the soil.) Regional EPA offices, state environmental offices, or the United States Geological Survey (USGS) (Ref. 10) may also be able to provide such information.
- Is the soil relatively permeable or impermeable? Since radon can diffuse more easily through porous or fractured earth, the presence of such soil can significantly influence the rate of travel of the radon.

Generally when radon is produced, some of the radon is retained in the solids of the soil or in the rock. A portion of it is also



released into the pores of the soil, where it can move either by diffusion or by convection. Diffusion is the movement of a gas from an area of high concentration to an area of lower concentration. Convection relates to the movement of a liquid or gas under a driving force, generally the difference in pressure between the atmosphere outside and inside a house or building.

When air pressure inside buildings is slightly lower than the pressure of the ambient air, the differential pressure forces radon through openings in the foundation. Slight pressure differentials can be caused by a number of factors such as wind, the operation of furnaces and exhaust fans, and the rising of warmer inside air, called the “stack effect”. Convection, which is highly dependent on the permeability of the soil, is considered the dominant method by which radon moves into a home or building.

Some of the significant potential radon entry routes include:

- cracks in exterior foundation walls;
- cracks in floor slabs;
- utility openings in slabs and walls;
- floor drains or sewer drains leading to a septic system that are not trapped;
- unsealed sump pits;
- weepholes in foundation walls;
- concrete joints; or
- pores in concrete masonry units when left unsealed.

Furthermore, since the size of a single radon particle is so small, it can often pass directly through common materials like paper, leather, low density plastic (i.e., plastic bags) most paints, and building materials like gypsum board, sheathing paper, wood, and insulation.

Reducing radon entry routes in basement foundation and slab-on-grade structures can often be achieved during construction at reasonable cost, since some of the procedures involved are also frequently used for waterproofing and moisture control. Basic steps include placement of a vapor barrier under concrete floor slabs and on the exterior of below-grade walls and elimination of open sump pits and other potential entry routes. Quality control to eliminate present or future cracks should also be emphasized.

Structures built on crawl spaces rely on reducing radon accumulation in the crawl space and on sealing openings into the dwelling. Buildings with a combination of foundation types require special attention during design and construction, but generally combine radon mitigation procedures from the three basic foundation types – basement, crawl space, and slab-on-grade.

## **7.3 Reducing Radon Entry**

### ***7.3.1 Concrete Masonry Basements***

When constructing concrete masonry basements, proper radon reduction techniques focus on:

- Restricting air/gas infiltration into the cores of the block, which could potentially infiltrate into the basement.
- Effective damp proofing or waterproofing.

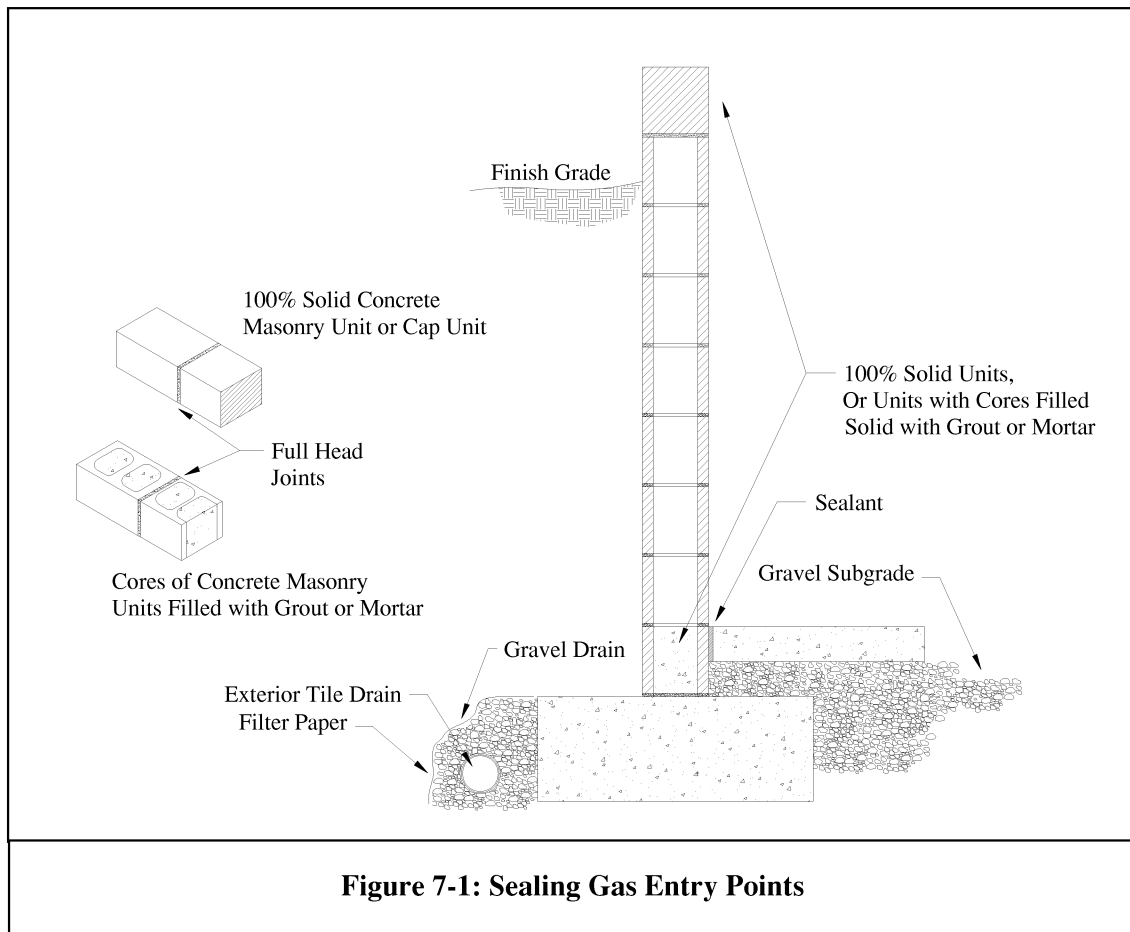
Providing a good quality barrier on the exterior surface of basement walls is an effective way to restrict radon entry through cracks, pores, or joints. In areas where radon is not known to be in abundance, good quality control when applying code-required damp proofing or waterproofing measures may be sufficient. In areas where elevated radon levels are expected, the use of an

additional barrier is recommended. An example of a barrier that is used in many applications is a 6-mil polyethylene sheet (roughly 6-8 times thicker than the standard plastic garbage sack) applied to the exterior surface of the wall from the finish grade to the bottom of the footing. In many areas of the country, this type of barrier is being incorporated into routine damp-proofing methods. Similarly, many waterproofing membranes are designed to bridge small cracks, further increasing their effectiveness as a radon barrier.

To improve the barrier and damp proofing performance and reduce the likelihood of gas infiltration through the foundation walls, proper crack control measures must be provided. These techniques are described fully in Chapter 5. Effective damp-proofing

and waterproofing procedures and materials can help protect a basement from soil gas entry as well as water entry. These are discussed fully in Chapter 4.

Although radon can percolate through nearly any construction material given the right circumstances, some measures are effective in significantly reducing the amount of radon entry. For example, in ungrouted or partially grouted construction, placing 100% solid units or fully grouted bond beams at the top and bottom of the wall resists radon entry into interim floors or above grade walls. It is also critical that full head joints be used for these courses as shown in Figure 7-1. Providing these solid courses will help prevent radon gas from migrating into the ungrouted cells of the wall and then into the living space of the structure.



**Figure 7-1: Sealing Gas Entry Points**

### 7.3.2 Crawl Spaces

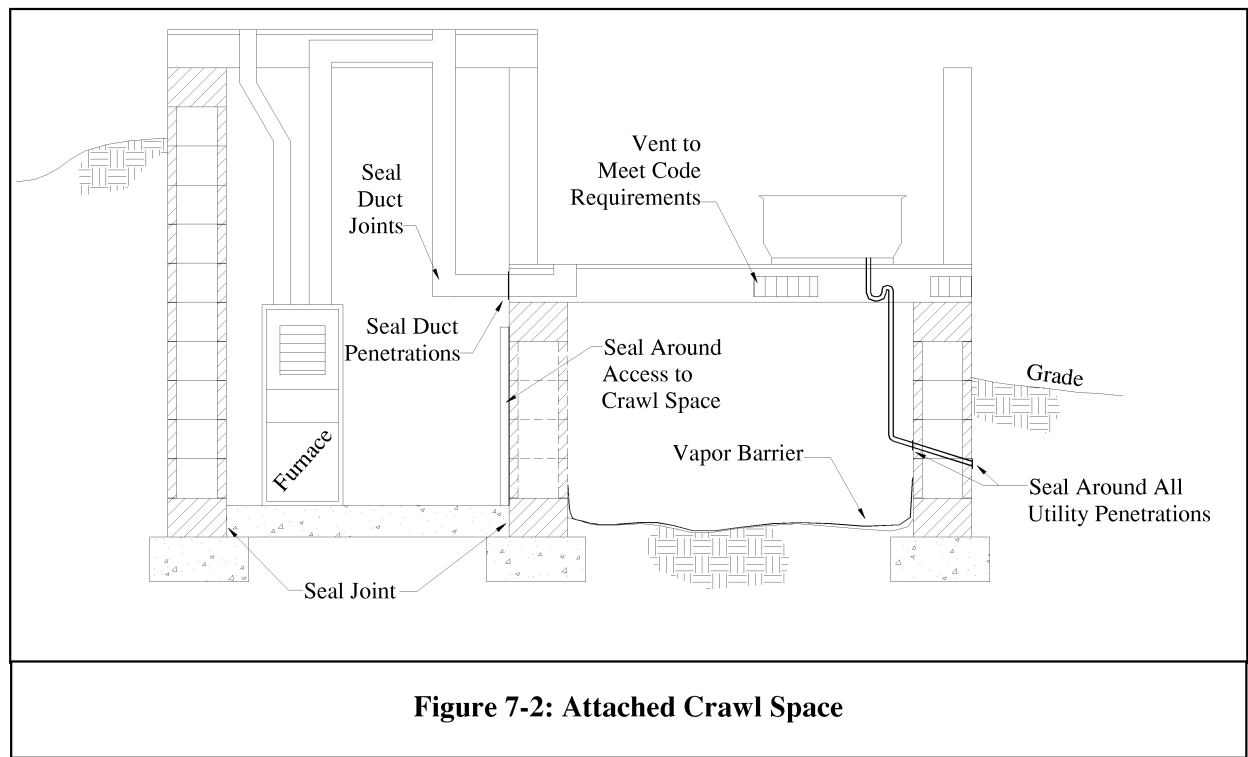
When crawl space walls are constructed so that the interior grade is below the exterior grade, they should be treated with an exterior barrier as with basement walls. Additional measures for crawl spaces include:

- Installing a ground cover manufactured of polyethylene, PVC, or equivalent material each having a minimum thickness of 6 mils. Ideally, the cover should be a continuous sheet firmly adhered to the walls around the perimeter. When a continuous cover is not practical, the seams should be lapped at least 6 inches and sealed to prevent the passage of gases.
- Whenever possible, ductwork should be located outside of the crawl space. If ducts are installed in the crawl space, all joints should be securely taped or otherwise sealed to reduce radon entry at these points.

- Careful sealing of all penetrations (sewer, water, electrical, gas, etc.) through the floor.
- Venting of the crawl space to the outside environment aids in eliminating the buildup of radon gases as well as moisture.

#### 7.3.2.1 Attached Crawl Spaces

An attached crawl space can be modified and treated as a basement or as a vented crawl space provided that space is isolated from the adjoining habited area by a concrete masonry wall, as shown in Figure 7-2. Walls between basements and crawl spaces should be provided with sealed doors and otherwise be rendered as airtight as possible. The top course of block and the course located at the level of the floor slab should be 100% solid, grout-filled, or otherwise treated to reduce the possibility of radon entry.



**Figure 7-2: Attached Crawl Space**

### 7.3.3 Slabs-On-Grade

When the construction consists of floor slabs bearing directly on the native soil or backfill, several precautions need to be addressed to minimize the potential for radon entry.

- Firm undisturbed native soil or a compacted subgrade is essential for ensuring uniform support of the floor slab – thereby reducing stresses that can lead to cracking of the slab. A 4-inch thick base of washed aggregate ( $\frac{3}{4}$  to 1½-inch diameter) can be used for the subgrade when the native soil is structurally unsound. The aggregate base is also a critical medium for subslab depressurization systems, if installed.
- The installation of isolation joints in accordance with recommendations established by the American Concrete Institute (Ref. 2) or the Portland Cement Association (Ref. 4). Joints may also be necessary to separate portions of the slab that deviate from a standard rectangular shape. Welded wire fabric installed throughout the slab may be used in place of control joints if placed at mid-depth of the slab. However, wire fabric is often placed on the bottom of the slab where its usefulness for crack control is reduced.
- Avoid over-excavating near footing and piers. Unsuccessful attempts to fill and re-compact under footings or piers may lead to foundation settlement, which can induce cracking in both the floor slab and the foundation walls.
- Use an appropriate concrete mix and strength, usually 3,000 psi or as required by the local building code. The recommendations of the American Concrete Institute (Ref. 2) for quality residential concrete placement should be followed.
- Proper procedures should be followed for curing the slab. Three wet curing

methods recommended by the Portland Cement Association (Ref. 4) are:

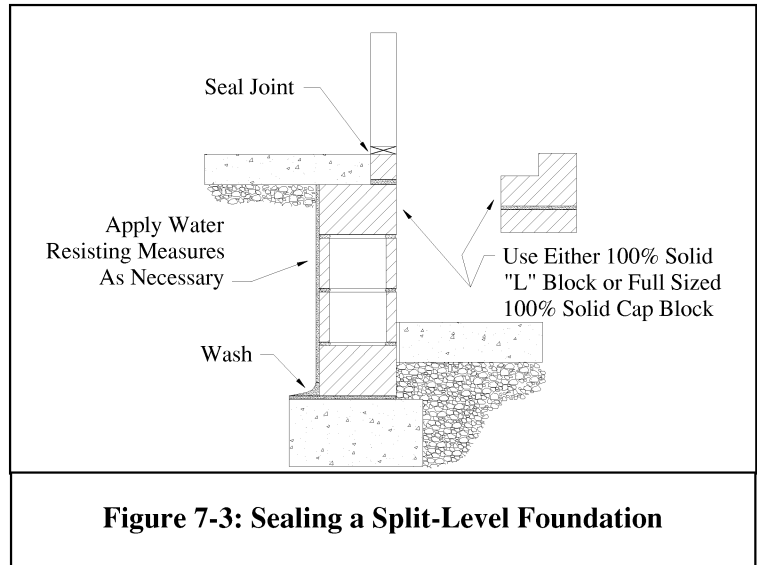
1. Wet-cure by fully covering the surface with wet burlap as soon as it can be placed without marking the surface. Keep the burlap continuously wet and in place as long as possible, but not less than several days.
  2. Wet-cure by fully covering the previously wetted surface with plastic sheeting or waterproof paper as soon as it can be placed without marking the surface. Keep in place as long as possible, but not less than several days.
  3. Seal the slab surface and edges by spraying a liquid-membrane-forming curing compound (also called a mono-molecular membrane) on the finished surface.
- As a redundant means of protection, it is good practice to chip out and fill any visible surface cracks that appear after construction with a suitable sealant.

Although improved quality can be achieved through the steps outlined above, a truly crack-free floor slab is nearly impossible to construct. Therefore, a vapor retarding barrier of 6-mil polyethylene, PVC, or equivalent material should be placed directly below the concrete slab and overlapped a minimum of 12 inches to insure complete coverage. Care should be taken to avoid puncturing the barrier while casting the floor slab. When utility lines penetrate the vapor barrier the openings should be sealed to inhibit the passage of water and gas at these locations. In addition to providing some degree of protection against radon entry by bridging cracks or other penetrations in the slab, the barrier will increase the effectiveness of a subslab depressurization system, if present, and prevent concrete from

seeping down into the aggregate and clogging the voids.

#### 7.3.3.1 Slabs at Different Elevations

Split-level foundations consisting of a slab-on-grade foundation adjoining a full or partial basement should be treated as two separate foundations, as shown in Figure 7-3. Exterior walls and the wall that separates the two areas should be provided with a barrier in the same fashion as the exterior walls of full basements.



If subslab depressurization is used, each subslab area should be fitted with separate stub-out pipes, unless piping or other means of providing flow between the upper and lower subslab areas is installed.

#### 7.3.4 Other General Precautions

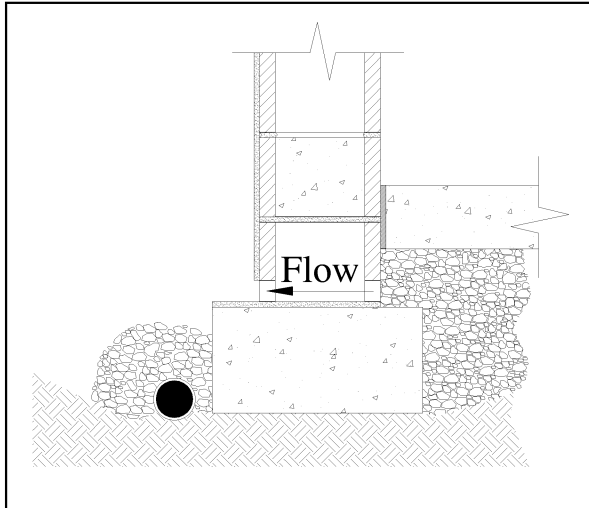
##### 7.3.4.1 Concrete Joints and Pipe Openings

Rarely is it possible to construct a building without some form of joints or penetrations. Where pipe penetrations, floor joints, or joints along the wall/floor interface occur, they should be sealed as best as feasibly possible. This process of sealing not only mitigates the seepage of soil gases, but also water and moisture. The wall/floor joints are effectively sealed by tooling the slab to receive a bead of sealant or, if an expansion material is used, by cutting the material back about ½ inch and filling with a generous bead of sealant. Any sealant that adheres to concrete, remains flexible, and has a relatively long life span (most polyurethane or silicone sealants meet these criteria) is satisfactory.

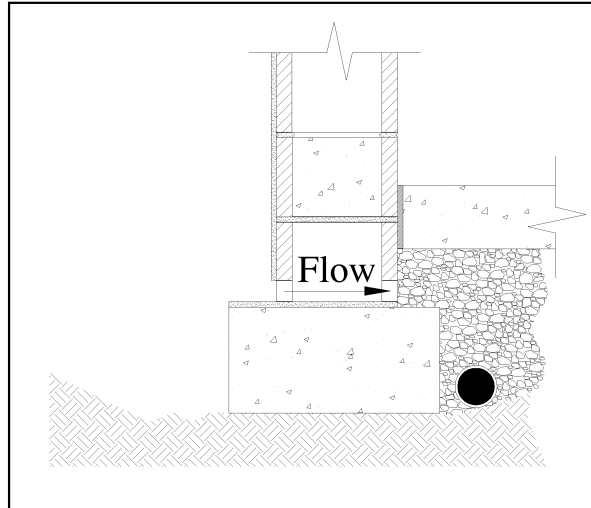
##### 7.3.4.2 Drainage Systems

The introduction of radon controls into construction has focused attention on various waterproofing practices that have long been employed, but that have the undesirable side effect of providing pathways for radon entry. The primary problem area involves practices that rely on direct access to subslab aggregate or soils as a pathway to divert water to a sump or to other drainage systems. Floor drains, sump pits, channel drains, and weepholes are examples of drainage techniques that may aggravate radon entry problems.

- Floor drains should be run through a solid pipe to daylight whenever possible. Important radon control problems can arise if drainage goes to a sump or to the subslab aggregate. A water trap can be provided, but it can dry out in time, and can remain effective only if the occupant takes the periodic precaution of refilling the trap with water. As an alternative, a mechanical trap can be installed.
- Condensation drains fitted to mechanical systems should be treated to prevent radon entry with a swing check valve or equivalent protection.



**Figure 7-4a: Wall Drain**



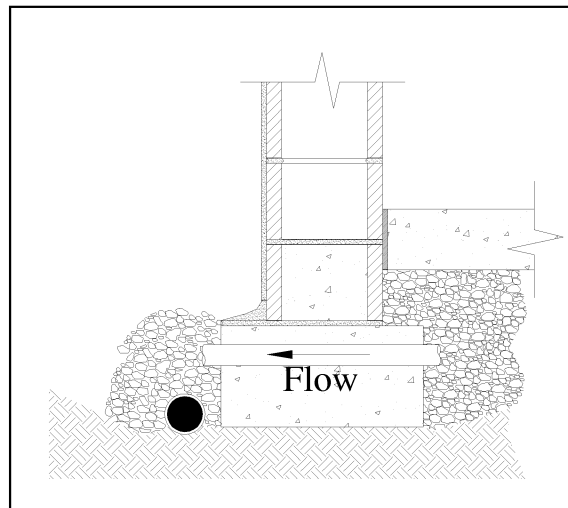
**Figure 7-4b: Wall Drain**

- Sumps are used when the foundation drainage system cannot drain by gravity. A sump typically consists of a pump within a hole in direct contact with the under slab area. Water entering the sump is pumped to a point at which it can drain away from the house by gravity. To close this potential radon entry rout, the sump pit should be fitted with an airtight cover. This may require use of a submersible pump to permit sealing of the sump hole at the floor level.

#### 7.3.4.2.1 Weepholes in Foundation Walls

If weepholes are employed where elevated radon levels are anticipated or known, extra precautions should be taken. These precautions include an active subslab depressurization system, and/or the application of sealants to interior wall surfaces.

Weeping strategies to effectively resist radon infiltration into the wall are shown in Figures 7-4a through 7-4c. The barrier of solid masonry is provided to prevent soil gases from entering the cores of the wall system. The barrier typically consists of



**Figure 7-4c: Wall Drain**

masonry with all cores filled with mortar or grout. If the through-the-wall drainage system is required only to provide drainage from the under slab to an exterior drain system or from the exterior to a subslab drain system, weepholes may be cast into the footing as shown in Figure 7-4c.

If elevated levels of radon are identified in buildings constructed with weeped wall systems, the interior of the concrete masonry wall should be sealed. Research by the

Environmental Protection Agency (Ref. 3) indicates that applying sealants to the walls may reduce air movement through masonry walls. To date, tests have been limited to small assemblies in a laboratory. However, the data suggests that effective sealant systems include:

1. two coats of water-based epoxy paint
2. two coats of elastomeric acrylic emulsion paint
3. one thick brush coat of portland cement plaster
4. one-eighth inch of surface bonding cement
5. two coats of polysulfide vinyl acrylic paint.

#### 7.3.4.2.2 Channel Drains

Channel drains should not be used where elevated radon levels are anticipated. If elevated levels of radon are subsequently discovered after channel drains are installed, the channel drains should be closed or vented. If the channel drains are left open, the effectiveness of other sealing techniques and of subslab depressurization will be decreased. Another approach is to install a sheet metal "baseboard" around the perimeter of the basement to cover the floor/wall joint. The duct is then ventilated with fans. Sealing the channel drains involves two steps. First, a "backer" material is wedged into the gap at the perimeter of the wall. The top surface of the backer material should be below the top of the slab. Second, a sealant is applied over the backer material. Typically, pourable polyurethane, applied as recommended by the manufacturer, is used for this purpose.

### 7.4 Radon Removal

The previously described methods are necessary steps for radon reduction in the construction of any new building where it is expected that elevated radon levels could

occur. However, they are not always completely effective and may need to be applied in combination with other measures for removal of radon prior to habitation. This is usually accomplished by some form of natural or mechanically aided pressure modification.

### 7.4.1 Depressurization

#### 7.4.1.1 Subslab Depressurization

Subslab depressurization reduces the radon level by intercepting and removing radon from under the slab before it can enter a building. This has been shown to be the most cost-effective and proven radon mitigation system when installed in combination with the measures for reducing entry routes.

Subslab depressurization involves:

1. Use of at least 4 inches of washed aggregate or an approved coarse woven geotextile matting under the slab. The aggregate or mat should be covered with a 6-mil polyethylene, PVC, or equivalent barrier to prevent concrete from seeping into the voids of the aggregate.
2. Installation of a 3 or 4-inch diameter vent stack, extending from the aggregate to a point above the roof. As an alternative, the stack can tap into the top of a sump lid, provided the sump is connected to an interior drain tile system or has direct open communication with the subslab aggregate. Rather than completing the pipe run to the roof, a 12-inch stub-out, as shown in Figure 7-5, can be installed. If necessary, the system can be completed at a later date. However, installing the vent stack during the initial construction of the building makes it much easier to activate the system in the future, if necessary. Other considerations include the following:
  - For pipes that are installed into the aggregate, a "tee" section will

prevent the pipe from bottoming out on the soil under the aggregate.

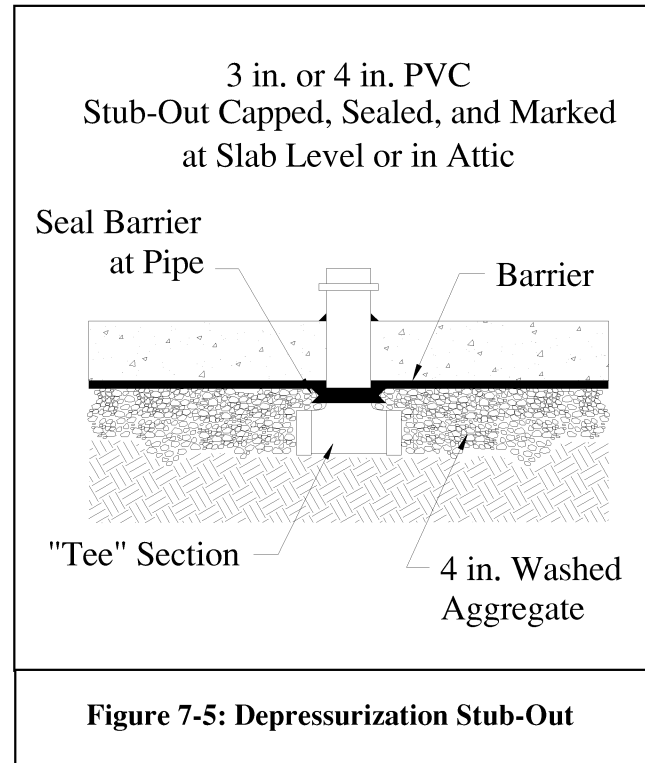
- The pipe can exit the building at some place other than above the roof, but it is usually less expensive to provide for an indoor rated fan and electrical hook-up, if required. If the vent stack exits in the foundation wall to the outdoors at grade level, avoid locating the stack near windows, doors and vents so the exhausted gases are not drawn back in to the building. Also, avoid locations where people might gather.
3. The vent stack should be appropriately marked as a radon mitigation system to ensure it is not mistaken for a water or sewer line.
  4. Installation of an axial fan depressurizes the area under the slab and draws radon through the vent pipe. In some installations, fans have also been used to pressurize the subslab area and force radon away from the foundation. The fan should be located in the attic or at another point outside the living space of the home to prevent re-entry if a leak should develop. Outside fans, which offer an alternative, must be protected from the elements.

#### 7.4.1.2 Perimeter Drain Depressurization

Perimeter drain or drain tile systems may be used to provide depressurization in a manner similar to subslab depressurization except that the stack is tied directly into an interior drain tile system placed around the perimeter of the foundation.

In areas where interior drain tile is not typically used, this approach may prove to be more expensive than direct venting of the subslab. One possible advantage, however, is that the connection to the drain tile can sometimes be made indoors at the sump.

This connection reduces the need for an additional slab penetration.



#### 7.4.2 Crawl Space Venting

Natural ventilation has been shown to be one of the most effective methods for radon control in crawl spaces. Non-operable foundation vents are typically used for this purpose. Minimum open vent area should be about 1 square foot of net free vent area for each 150 square feet of crawl space floor area, or as otherwise specified in local building codes.

The ventilation area should be evenly distributed on at least three, and preferably four, sides of the foundation and located as close to building corners as possible. Care should be taken to avoid conditions leading to frozen pipes. Forced ventilation of crawl spaces may be needed only in extreme cases. If natural ventilation is not effective, a fan to circulate crawl space air at one to three air changes per hour may be desirable.



### ***7.4.3 Attached Crawl Space Venting***

A crawl space that is attached to a basement should be isolated from the basement and vented in the same fashion as a traditional crawl space. Penetrations in the wall between the crawl space and the basement should be sealed airtight. An attached crawl space can be modified by pouring a thin slab over the aggregate and installing a subslab depressurization as for a basement.

# Chapter 8 Construction

## 8.1 Introduction

Foundation and basement walls can be constructed in a variety of ways using different techniques, materials, and methods. However, regardless of the type of construction, each wall relies on quality assurance measures to be taken in accordance with the structural design and the project specifications to ensure successful performance. Generally, concrete masonry wall construction is straightforward and follows accepted industry standards. Figures 8-1 through 8-3 show typical construction details for concrete masonry basements. Explanatory notes provide further

information regarding specific aspects of typical basement construction.

To aid owners, designers, and specifiers of concrete masonry foundation walls, Reference 7 outlines minimum project specifications for masonry construction. The guide specification can be modified accordingly to meet the desired properties above the established minimum requirements in the specification.

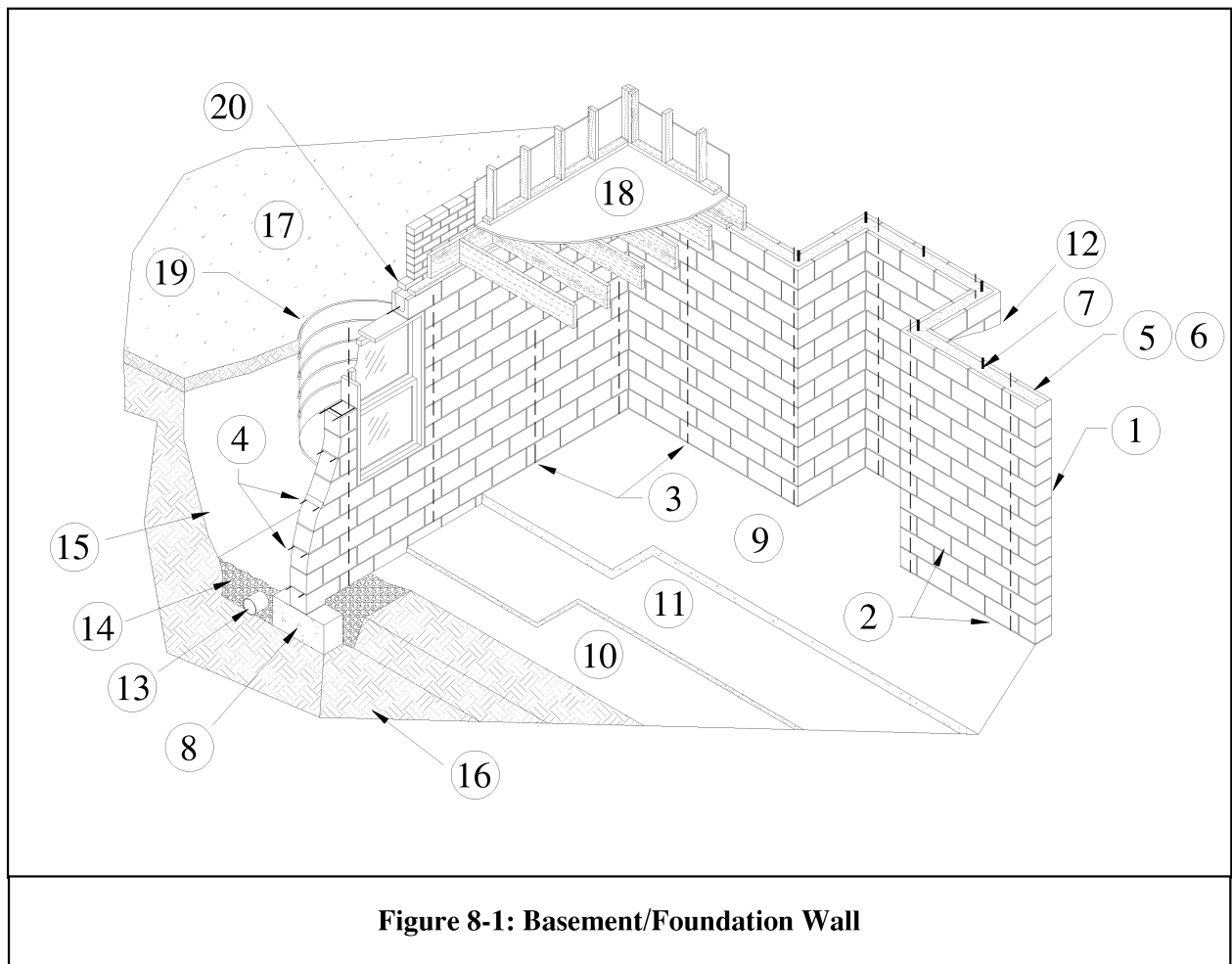


Figure 8-1: Basement/Foundation Wall

*Notes to Figures 8-1, 8-2, and 8-3*

1. Concrete masonry units. Typical basement construction of residential structures utilizes hollow concrete masonry units having an 8-inch (203 mm) nominal thickness. However, larger size units may be necessary depending on the anticipated design loads.
2. Mortar. Type S mortar is generally recommended for use in foundation wall construction. The first bed joints in a wall should fully bed the units even if face shell bedding is used on the remainder of the wall. Care should be taken to keep mortar off the footing surface where units are to be grouted. The initial bed joint may vary from ¼ to ¾ inch to make up for irregularities in the footing surface. Joints should be tooled (unless the wall is to be parged) to reduce the potential for water penetration and to increase soil gas resistance.
3. Vertical reinforcing bars. When necessary, reinforcement should be placed adjacent to openings, in all corners, and spaced as determined from a structural analysis. Rebar positioners may be used to hold the reinforcing bars in their proper position.
4. Joint reinforcement. To reduce the potential of shrinkage cracking and to meet certain code requirements, horizontal reinforcement in the form of joint reinforcement or deformed bars may be required. Further detail on reinforcement requirements is provided in Chapter 2 and Chapter 5.
5. Grout. Cells containing reinforcing bars must be grouted solid so that stresses can be transferred from the masonry, through the grout, to the reinforcing steel. Grout must have a minimum compressive strength of 2,000 psi (13.79 MPa) and

- must be consolidated by puddling or vibration to reduce voids.
6. Solid top course. A solid grouted and reinforced top course spreads loads from the superstructure uniformly to the foundation walls. A solid grouted top course, or top course comprised of 100% solid units also increases the soil gas and termite resistance of the building.
  7. Anchor bolts. For residential basements, typically 7 inches long, ½ inch diameter anchor bolts are spaced no more than 4 feet on center (or as required by local codes) to attach the home to the foundation walls. Anchor bolts significantly increase the earthquake and hurricane resistance of a home.
  8. Footing. Footings distribute loads from the foundation walls to the supporting soil. Poured concrete footings should have a minimum strength of 2,500 psi and should be at least 6 in. thick, although many designers prefer footings to be as thick as the wall thickness and twice as wide as the wall thickness, but should comply with local practice and building requirements. Placing reinforcement in the footings increases the footing's ability to span weak or poor soil areas and reduces the potential for development of large cracks. Prior to final set of the concrete, the top surface of the footing should be intentionally roughened to produce a surface texture with amplitude of at least 1/16 inch. This intentional roughening facilitates the bond between the units and the footer.
  9. Concrete slab. Typically a minimum 2,500 psi 4 inch thick concrete slab is required to allow the slab to span over weak soil areas without excessive cracking. Contraction joints should be provided to reduce shrinkage cracking in the slab. Welded wire fabric can also be placed in the slab to limit the formation

of large cracks. Welded wire fabric should be carefully placed and supported so it is near the center of the slab. If contraction joints are incorporated into the slab, the welded wire fabric should not be continuous through these joints.

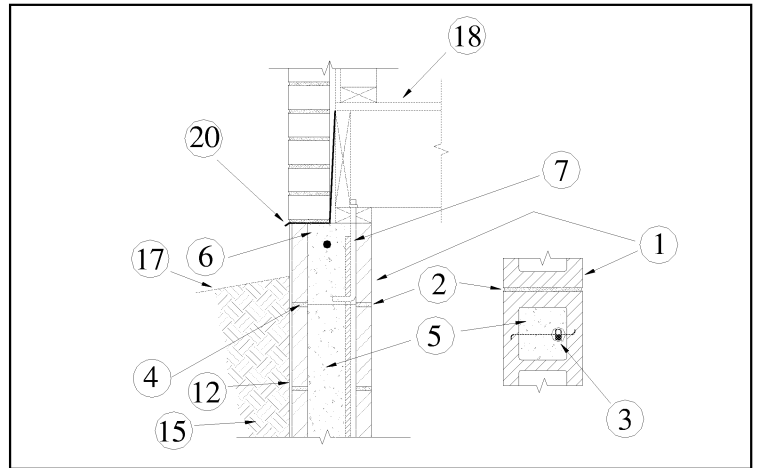
10. Aggregate base. A 4 to 6 inch base of washed aggregate ( $\frac{3}{4}$  to 1  $\frac{1}{2}$  inch diameter) distributes slab loads evenly to the underlying soil, provides a level clean surface for workers to place the slab on, and allows for the inclusion of a soil gas depressurization system or water mitigation system.
11. Vapor barrier. Continuous or lapped sheets of 6-mil polyethylene, PVC, or equivalent material reduce rising dampness problems and retard soil gas infiltration through the bottom of the slab. Vapor barriers (retarders) are often placed on top of the aggregate base to increase the effectiveness of the soil gas barrier system and prevent the wet concrete from filling the voids between the aggregate. However, for some circumstances, the vapor barrier may also be placed directly on the ground.
12. Waterproof or damp-proof membrane. Below grade masonry walls should be damp-proofed in areas where hydrostatic pressure will not occur. Where ground water levels are high, soil drainage slow, or where radon gas levels are high, consideration of waterproof membranes such as rubberized asphalt, polymer-modified asphalt, or butyl rubber should be considered. Drainage boards can also be used to drain water quickly and to reduce backfill pressure.
13. Foundation drain. Perforated PVC pipe or drain tile are required to collect and transport ground water away from the basement. Drains should be located below the top of the slab and should be sloped away from the house to natural

drainage, a storm water sewer, or a sump.

14. Free draining backfill. At least 12 inches of washed gravel or other free draining backfill materials should be placed around drains to facilitate drainage. To prevent backfill from being washed into the drain, cover the top of the washed gravel with a filtering geotextile.
15. Backfill. Backfill should preferably be free draining material and should only be placed after the wall has gained sufficient strength and has been properly braced or supported.
16. Undisturbed soil. Soil beneath footings and slabs should be undisturbed, or where native soil is insufficient to carry foundation loads it should be excavated and a new backfill should be placed and compacted in its place.
17. Top of grade. The soil surrounding the foundation should always slope away from the building so that precipitation and runoff drains away from the basement walls. Where the surrounding terrain naturally slopes towards a home, swales or trenches should be installed to intercept runoff. The top 4 to 8 inches of the soil adjacent to the foundation should be of low permeability so that water is slowly absorbed into the soil or drained away from the foundation.
18. Floor diaphragm. The floor diaphragm supports the tops of the masonry walls and acts to distribute the superstructure loads to the foundation walls.
19. Window well. Window wells allow natural lighting into basements with fully backfilled walls. A variety of window wells are available, including wells constructed of concrete masonry units. Concrete masonry wells can be sealed at the top and left open to the interior of the basement, serving as a plant or display

shelf. It is important to provide adequate drainage at the bottom of the well to ensure water does not build up against the window frame. Typically, the bottom of the window well sits on free-draining backfill, which may also be tied into the foundation perimeter drain. Prefitted plastic bubbles are also available to prevent leaves or debris from collecting within the well and to protect against a possible falling hazard. These bubbles also keep water out of the well, lessening the need for drainage at the bottom of the well. Special care should be taken to ensure continuity of the foundation water repellent system around the window well to reduce the possibility of leakage.

20. **Flashing.** Flashing should always be installed at the top of basement walls to prevent water from entering the wall from the exposed portion of the structure.
21. **Geotextile.** A filtering geotextile material inhibits the migration of fine soil materials into the drain, thereby preventing clogging.



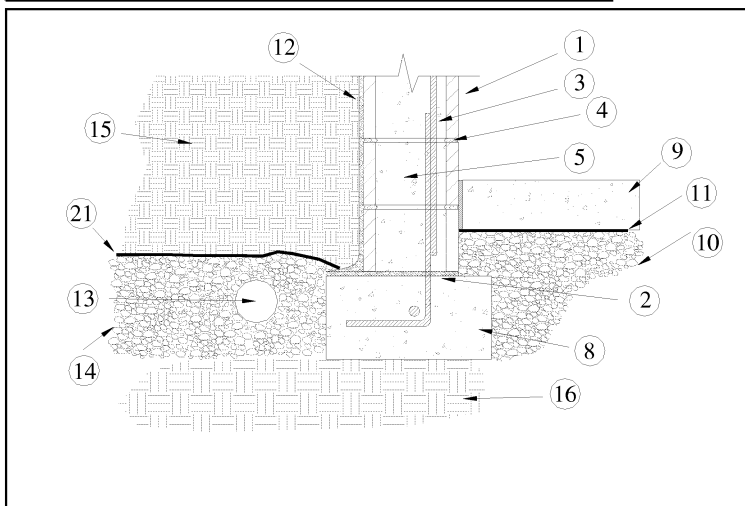
**Figure 8-3: Typical Floor Connection**

## 8.2 Materials

### 8.2.1 Concrete Masonry Units

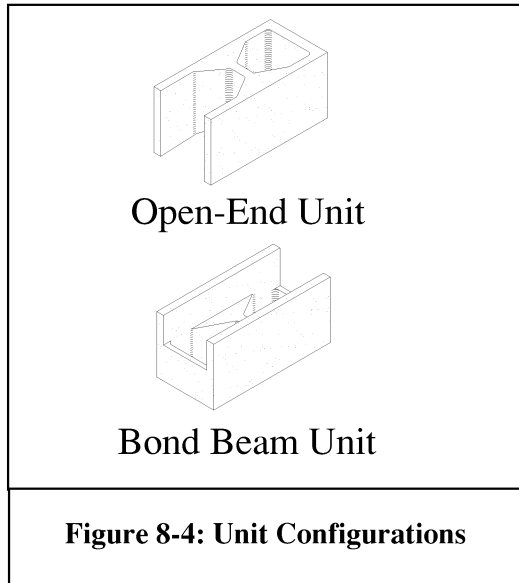
#### 8.2.1.1 Concrete Masonry Unit Properties

Concrete masonry units for basement and foundation wall construction must comply with ASTM C 90, *Standard Specification for Loadbearing Concrete Masonry Units* (Ref. 5-A). Although not covered by ASTM C 90, specific colors and textures may be specified to provide a desired finish to the foundation wall.



**Figure 8-2: Typical Footing Detail**

Numerous types of concrete masonry units are available to provide a wide variety of appearances and ease of construction. There are also a variety of units that facilitate reinforced masonry construction, thus potentially reducing difficulties and the cost of construction. Open-end block and bond beam units allow for easy and rapid placement of both the masonry units and the reinforcing steel. (See Figure 8-4.) Open-end block are recommended for solid grouted construction and whenever vertical reinforcing steel must be placed before the masonry units. The open ends of these units allow the mason to easily



place the units around the vertical reinforcing bars, rather than lifting closed-end units up and over the vertical reinforcing steel. Closed-end units however are still popular for partially grouted construction, where the vertical steel can be placed after the masonry units, or when the total height of the vertical reinforcement is relatively small.

Bond beam units allow for the installation of horizontal reinforcing bars without the need for cutting the units. On projects with closely spaced vertical reinforcing steel, the use of open-ended bond beam units may be justified.

### 8.2.1.2 Concrete Masonry Unit Admixtures

During the manufacturing process of concrete masonry units, chemical admixtures can be added to the mix to enhance a specific given property such as water repellency. (However, to be effective, if an integral water repellent admixture is added to the units, the same admixture must be added to the mortar during construction.) Such admixtures are not outlined under the minimum requirements established in ASTM C 90 and should be specified separately by the purchaser of the units. Local suppliers should be consulted as to the availability of various admixtures.

### 8.2.2 Mortar

Mortar serves several important functions in a concrete masonry wall; it bonds the units together, seals joints against air and moisture penetration, and bonds to bed joint reinforcement, ties, and anchors so that all components perform as a single structural element.

#### 8.2.2.1 Mortar Materials

Masonry mortar should comply with the provisions established in ASTM C 270, *Standard Specification for Mortar for Unit Masonry*, (Ref. 5B). Type S mortar is typically used for basement wall construction, although Type M or Type N mortar can be used when conditions permit. Type M and S mortars provide high

**Table 8-1: Mortar Proportions by Volume** <sup>(Ref. 5-B)</sup>

Mortar	Type	Cement	Lime or Lime Putty	Aggregate Ratio
Portland Cement-Lime	M	1	¼	Not less than 2 ¼ and not more than 3 times the sum of the separate volumes of cementitious materials.
	S	1	Over ¼ to ½	
Mortar Cement	M	1	---	
	S	1	---	
Masonry Cement	M	1	---	
	S	1	---	

<b>Table 8-2: Grout Proportions by Volume</b> <sup>(Ref. 5-C)</sup>				
Type	Parts by Volume of Portland Cement or Blended Cement	Parts by Volume of Hydrated Lime or Lime Putty	Aggregate, Measured in a Damp Loose Condition	
			Fine	Coarse
Fine Grout	1	0- <sup>1</sup> / <sub>10</sub>	2 ¼ to 3 times the sum of the volumes of the cementitious materials	---
Coarse Grout	1	0- <sup>1</sup> / <sub>10</sub>		1-2 times the sum of the volumes of the cementitious materials

compressive strengths, increased bond strengths, and long-term durability against the environment. Table 8-1 lists mortar proportions by volume for the various mortar types. However, one should always verify compliance with local codes as some regions of the Country do not allow the use of masonry cement mortars depending on the type of structure and the seismic risk of the region.

#### 8.2.2.2 Mortar Mixing

Mortar materials should be mixed for not less than 3 minutes in a mechanical batch mixer to ensure all materials are thoroughly mixed, and not more than 10 minutes to avoid over mixing. On small jobs, it may be acceptable to hand mix the mortar. Similarly, if factory blended dry mixes are used, they too must be thoroughly mixed in a mechanical mixer until workable, but again, for not longer than 10 minutes.

While there is no requirement for the volume of water that should be added to a mortar mix, sufficient water should be added so as to produce a workable mortar consistency. The amount of water added may vary from day to day depending on the environmental conditions at the job site. A qualified mason can accurately judge the amount of mixing water necessary for the specific job conditions. Once mixed, mortar can be retempered to its original consistency

by adding water. Mortar that has not been used within 2½ hours after mixing (or less depending on the environmental conditions) should be discarded to avoid using mortar that has begun to set due to hydration.

#### 8.2.2.3 Mortar Admixtures

Like concrete masonry units, various mortar admixtures are available to enhance various properties of the mortar. Such admixtures include:

- workability enhancer;
- integral water repellent;
- time of set of the mortar; or
- bond enhancer.

ASTM C 1384 *Standard Specification for Modifiers for Masonry Mortar* (Ref. 5F) provides detailed information on the anticipated benefits of mortar admixtures.

### 8.2.3 Grout

#### 8.2.3.1 Grout Materials

In reinforced concrete masonry construction grout is used to bond the reinforcement and the masonry together. Grout should conform to the requirements established in ASTM C 476, *Standard Specification for Grout for Masonry* (Ref. 5C). ASTM C 476 contains two provisions for specifying either coarse or fine grout – the proportion specification and the property specification. (Unless unique conditions exist, coarse grout is almost exclusively used in concrete masonry construction.) Meeting the

proportion specification requires adding materials to the grout mix in accordance with Table 8-2. As an alternative to complying with the proportion requirements in Table 8-2, grout can be specified to have a minimum compressive strength (not to be less than 2,000 psi after 28 days of curing) when tested in accordance with ASTM C 1019, *Standard Test Method for Sampling and Testing Grout* (Ref. 5D).

Sufficient water should be added to the grout so that it will have a slump of 8 to 11 inches. (The slump of the grout is a measure of how well the grout will flow, determined on a scale of 0 to 12 inches, with 12 inches being the highest. A slump that is too low can result in placement problems and inadequate consolidation of the grout. A slump that is too high can decrease the compressive strength of the grout and cause segregation of the grout materials.) The high slump allows the grout to be fluid enough to flow around reinforcing bars and into small voids. This (initially) high water-to-cement ratio (the ratio of the weight of water in the grout to the weight of cement) is reduced significantly as the masonry units absorb excess mix water. Thus, grout attains a high compressive strength despite the initially high water-to-cement ratio. Conversely, having an initial water-to-cement ratio that is too low does not provide sufficient water for the cement to hydrate once the units absorb the water. Furthermore, the use of such stiff grout leads to difficulties in consolidation and often results in a large number of voids within the finished product. Because of the initially high water content, grout should be consolidated and reconsolidated by mechanical vibration or puddling to remove voids created by the loss of water.

#### 8.2.3.2 Grout Admixtures

Admixtures for grout are also available to reduce the volume loss due to the absorption of the water from the grout as well as increase the slump (workability) of the grout.

#### 8.2.4 Reinforcing Steel

Reinforcing steel increases the flexural strength and ductility of concrete masonry walls thereby providing increased resistance to applied loads. The two principal types of reinforcement used in masonry walls are reinforcing bars and horizontal bed joint reinforcement.

Reinforcing bars are available in the United States in eleven standard bar sizes designated No. 3 through 11, No. 14, and No. 18 each having the corresponding diameter shown in Table 8-3. However, recently the manufacturers of reinforcing steel have begun to supply conventional rebar sizes in their corresponding metric equivalents. As a result, although the sizes and properties of the reinforcing steel have not changed, the method in which they are designated has been modified.

In accordance with the MSJC (Ref. 8) and the International Building Code (Ref. 6), bars larger than No. 11 are not permitted in masonry construction. Furthermore, the strength design provisions of the International Building Code impose additional stipulations on the diameter of the reinforcement for masonry designed in accordance with the strength design provisions. These limitations limit the diameter of the reinforcement to less than one-eighth the nominal wall thickness and less than one-quarter of the least dimension of the area in which the steel is placed. These added requirements are intended to



facilitate consolidation of the grout and increase the overall ductility of the structure.

Reinforcement or bolts with ¼ inch diameter or smaller may be placed in bed joints which are at least twice the thickness of the reinforcement or bolts.

Bar Size	Nominal Diameter, in.	Nominal Area, in <sup>2</sup>
No. 3 (M #10)	0.375 in. (9.5 mm)	0.11 in <sup>2</sup> (71 mm <sup>2</sup> )
No. 4 (M #13)	0.500 in. (12.7 mm)	0.20 in <sup>2</sup> (129 mm <sup>2</sup> )
No. 5 (M #16)	0.625 in. (15.9 mm)	0.31 in <sup>2</sup> (200 mm <sup>2</sup> )
No. 6 (M #19)	0.750 in. (19.1 mm)	0.44 in <sup>2</sup> (284 mm <sup>2</sup> )
No. 7 (M #22)	0.875 in. (22.2 mm)	0.60 in <sup>2</sup> (387 mm <sup>2</sup> )
No. 8 (M #25)	1.000 in. (25.4 mm)	0.79 in <sup>2</sup> (510 mm <sup>2</sup> )
No. 9 (M #29)	1.128 in. (28.7 mm)	1.00 in <sup>2</sup> (645 mm <sup>2</sup> )
No. 10 (M #32)	1.270 in. (32.3 mm)	1.27 in <sup>2</sup> (819 mm <sup>2</sup> )
No. 11 (M #36)	1.410 in. (35.8 mm)	1.56 in <sup>2</sup> (1006 mm <sup>2</sup> )
No. 14 (M #44)	1.693 in. (43.0 mm)	2.25 in <sup>2</sup> (1452 mm <sup>2</sup> )
No. 18 (M #58)	2.257 in. (57.3 mm)	4.00 in <sup>2</sup> (2581 mm <sup>2</sup> )

Cold drawn wire for masonry joint reinforcement varies from W 1.1 (11 gauge) to W4.9 (¼ inch diameter), the most popular size being W1.7 (9 gauge). Wire joint reinforcement is required to fit inside mortar joints, and since current codes limit the size of wire to one half the joint thickness, the practical limit for wire diameter is <sup>3</sup>/<sub>16</sub> inch for a <sup>3</sup>/<sub>8</sub> inch thick mortar joint.

Prior to placement, the MSJC (Ref. 7 and 8) requires reinforcement to be free from loose rust and other foreign debris that would otherwise inhibit bond between the steel and grout. Grout and masonry units usually provide adequate corrosion protection for embedded reinforcing bars provided that minimum clearance requirements are met. The Masonry Standards Joint Committee (Ref. 7) requires a minimum <sup>5</sup>/<sub>8</sub>-inch mortar cover between ties or joint reinforcement and any face exposed to earth or weather and ½ inch mortar cover when not exposed to earth or weather. A minimum of ¼-inch of grout or mortar cover must be provided between masonry units and joint reinforcement when using fine grout and a minimum of ½ inch for coarse grout.

### 8.3 Footing Construction

The footing system transfers loads from foundation walls into the supporting soil. Footings must be properly designed and constructed to ensure the applied bearing pressure does not exceed the allowable bearing capacity of the soil. Footings for foundation walls are typically constructed of strip

concrete or solid masonry.

The footing must be placed deeper than the frost level to prevent damage and heaving caused by freezing of water present in the soil. (The depth of the frost level varies significantly by region. Check with your local building official for the frost level in your area.) Footings should be placed on undisturbed native soil, unless this soil is unsuitable (i.e., containing large amounts of clay or organic material), weak, or soft. Unsuitable soil should be removed and replaced with compacted soil, gravel, or concrete. Similarly, tree roots, construction debris, ice, and any other debris should be removed prior to placing the footings.

To limit the amount of time the underlying soil is exposed to rain and snow, footings should generally be constructed as soon as possible after excavation. Where soil has become wet and soft, the affected area should be removed, backfilled, and compacted with an appropriate soil or gravel.

A 4 to 6 inch layer of gravel is recommended beneath the entire basement slab surface to provide a working area for the masons, a uniform and stable bed for the slab, and a drainage path for water and soil gases. Likewise, utility trenches should be filled with compacted gravel or concrete before construction of the footings.

The concrete masonry wall and footing must be carefully constructed so that the center of the wall and the center of the footing are aligned. The top of the footing must also be relatively level and true to facilitate the construction of the concrete masonry foundation walls. Note that although the top surface of poured concrete footings should be relatively level, this surface should generally not be troweled smooth. Instead, a slightly roughened footing surface enhances the mechanical bond between the grout, mortar, and footing.

As a general guideline, footings should be at least 6 inches thick (although many designers prefer to make the footing as thick as the wall thickness) and roughly twice as wide as the wall thickness, but should comply with local practice and building requirements. Placing reinforcing bars in the footing helps reduce cracking and differential settlement problems (see Figure 8-2). Larger, or more heavily reinforced footings may be required on weak soil or to carry extremely heavy loads.

Concrete for footings and the slab should have a minimum strength of 2,500 psi. In contrast to masonry grout, excessive water should not be added to the concrete since doing so can significantly decrease the strength and durability of the concrete.

Drains may be cast into or placed on top of concrete footings to allow moisture on the

exterior of basement walls to effectively drain to subfloor drainage systems and sumps. (Refer to Figures 7-4a through 7-4c.) With this system, moisture passes through the gravel bed on the exterior side of the wall and flows through the drainage tubes to the subfloor drainage system, where it is expelled by a sump pump. Alternatively, drainage holes can be placed in the first course of masonry if space between the bottom of the slab and the top of the footing permits. These openings in the concrete masonry units allow any possible moisture or condensation within the masonry wall to exit to the subfloor or exterior drainage system.

## **8.4 Concrete Masonry Construction**

### ***8.4.1 Laying of Units***

Prior to laying the first course of masonry, the top of the footing must be cleaned of mud, dirt, ice, or other debris that may reduce the bond between the wall and the footing. This can usually be accomplished using brushes or brooms, although excessive oil or dirt may require sand blasting, pressure washing, or chemical cleaning of the concrete surface.

Masons typically lay the corners of the basement first so that alignment is easily maintained. This also allows the mason to plan where cuts are necessary for window openings or to fit the building's plan.

To make up for surface irregularities in the footing, the first course of masonry is set on a varying thickness mortar bed joint which can range from  $\frac{1}{4}$  to  $\frac{3}{4}$  inch in thickness. This initial bed joint should fully bed the first course of masonry units, although mortar should not excessively protrude into cells that will be grouted to allow the grout to bond directly to the footing.

All other mortar joints should be roughly  $\frac{3}{8}$  inch thick and, except for partially grouted masonry, need only provide face shell bedding for the masonry units. In partially grouted construction, webs adjacent to the grouted cells are mortared to restrict grout from flowing into ungrouted areas. Head joints must be completely filled for a thickness equal to the face shell thickness of the units.

Tooled concave joints may be used since they provide the greatest resistance to water penetration. If necessary, mortar joints may be cut flush to enhance the bond of some applied waterproofing materials.

When joint reinforcement is used, it is placed directly on the block with mortar placed over the reinforcement in the usual method. A mortar cover of at least  $\frac{5}{8}$  inch should be provided between the exterior face of the wall and the joint reinforcement. A mortar cover of only  $\frac{1}{2}$  inch is needed on the interior face of the wall (Ref. 7).

For reinforced masonry construction, the reinforcing bars must be properly located to be fully functional. In most cases, vertical bars are positioned toward the interior face of foundation walls to provide the greatest resistance to soil pressures. To prevent the bars from moving out of position during grouting, they can be held in position with bar positioners or other acceptable devices at intervals of approximately 200 bar diameters. For coarse grout, a space of at least  $\frac{1}{2}$  inch is required to be maintained between the bar and the face shell of the block so that grout can flow completely around the reinforcing bars.

#### **8.2.4 Grout Placement**

There are two grout placement procedures in general use: (1) low-lift grouting, where the

grout is placed in pours up to 5 feet in height and no cleanouts are needed; and (2) high-lift grouting, where grout is placed in pour heights as given in Table 8-4 and cleanout holes are required at the bottom of each grout space containing reinforcement.

A lift is the layer of grout placed in a single continuous operation, and must not exceed 5 feet in height. A pour is the entire height of the wall being grouted prior to the erection of additional masonry, and may be composed of a number of successively placed grout lifts.

##### **8.4.2.1 Low-Lift Grouting**

Low-lift grouting is often the simplest method of grouting concrete masonry. The potential drawback associated with low-lift grouting techniques is that even for small projects, grouting operations may need to be continued over multiple days. The advantage is that low-lift grouting requires no special concrete block shapes or equipment. The wall is built to scaffold height, or to a bond beam course, (up to a distance of 5 feet) reinforcing bars are then placed in the designated hollow cells of the block and the cells are grouted. The level of the grout is stopped at least  $1\frac{1}{2}$  inch from the top of the masonry to provide an interlocking shear key between the previous and the next grout lift. The steel reinforcement projects above the top course for sufficient height to provide an adequate splice.

The grout should be moved from the mixer to the point of deposit as fast as practical. Placement methods should prevent segregation of the mix and cause a minimum of grout splatter on reinforcement and on masonry unit surfaces not being immediately encased in the grout fill. On small projects, handle and place the grout carefully with

**Table 8-4: Grout Space Requirements**<sup>(Ref. 7)</sup>

Grout Type	Maximum Grout Pour Height, ft	Minimum Width of Grout Space, in.	Minimum Grout Space Dimensions for Grouting Cells of Hollow Units, in. x in.
Course	1	1 ½	1 ½ x 3
Course	5	2	2 ½ x 3
Course	12	2 ½	3 x 3
Course	24	3	3 x 4

buckets equipped with spouts, such as a coal scuttle. On large projects, grout pumps or concrete buckets equipped with chutes and handled with lift trucks are frequently used.

As mix water is absorbed by the units, air voids can form within the grout. Accordingly, grout must be consolidated as it is placed – and reconsolidated after placement to reduce these voids and to increase the bond between the grout and the masonry units. Codes (Ref. 6 and 7) permits puddling of grout when it is placed in lifts less than 12 inches high. Puddling is usually done with a 1 x 2 inch wooden stick. Lifts over 12 inches must be mechanically consolidated and then reconsolidated before initial set takes place. The reconsolidation overcomes settlement shrinkage separations of the grout from the reinforcing steel and promotes bond to the masonry units.

Between each grout pour, stop the grout at least 1 ½ inch below a mortar joint, except at the top of the wall. Where bond beams are incorporated into solid grouted masonry construction, stop the grout at least ½ inch below the top of the masonry. This forms a horizontal construction joint below the mortar joint, resulting in a grout key across the joint.

#### 8.4.2.2 High-Lift Grouting

In high-lift grouting, the grouting operation is done after the concrete masonry wall is complete (up to a height of 24 feet).

Cleanouts located at the bottom of each cell containing vertical reinforcement are required for high-lift grouting. High-lift grouting does offer certain advantages, especially on larger projects. One advantage is that a larger volume of grout will be placed at one time, permitting the economical use of more expensive equipment, such as a grout pump. A second advantage, in some instances, is that the full story height can be constructed before placing the vertical steel. Less steel is used for splices, fewer block will need to be threaded over the reinforcement, and the location of the steel can be easily inspected through the cleanouts prior to grouting.

Proper preparation of the grout space before grouting is very important. Remove all foreign materials or debris through cleanout openings at the bottom of all cores containing vertical reinforcement in partially grouted masonry but not more than 32 inches on center in solid grouted walls. The cleanout openings should be at least 3 inches by 4 inches. The cleanout openings in the face shells of units should be made before successive courses are laid.

After the wall is laid up to story height, remove all mortar droppings and mortar fins projecting more than ½ inch into the cells to be grouted. The grout spaces should be checked for cleanliness and proper reinforcement position, then the cleanouts are closed by mortaring in pieces of masonry

face shells or by forming over the openings to allow grouting to the plane of the wall. Face shell plugs or mortared units should be adequately braced to resist the pressure of the fluid grout.

For economical placement, pump a uniform height of grout in maximum 5 feet lifts and immediately vibrate the grout. The first vibration should closely follow the grout placement. Reconsolidate each lift by vibration before initial set takes place to allow for settlement and absorption of excess water. Succeeding lifts of grout must be poured not more than 60 minutes after the first lift. The waiting period depends on weather conditions and absorption rates of the masonry. Consolidation of a lift and reconsolidation of the preceding lift may also be done at the same time. Repeat the pouring and reconsolidation until the top of the pour is reached. Reconsolidate the top lift after the required waiting period and fill any space left by settlement shrinkage.

## **8.5 Construction Tolerances**

The MSJC (Ref. 7) includes tolerance requirements for installation of reinforcement and ties to ensure that elements are placed as assumed in the design, so that structural performance is not reduced. These requirements also minimize corrosion by providing for a minimum amount of masonry and grout cover around reinforcing bars, and ensure that there is sufficient clearance for grout and mortar to surround reinforcement and accessories, so that stresses can be properly transferred.

### ***8.5.1 Tolerances for Placement of Reinforcing Bars***

A minimum clear distance between reinforcing bars and the adjacent face of a masonry unit of  $\frac{1}{4}$  inch for fine grout or  $\frac{1}{2}$  inch for coarse grout must be maintained to

ensure grout can flow around the bars. In addition, a minimum amount of masonry cover over reinforcing bars is required to retard corrosion of the steel. This masonry cover is measured from the exterior masonry surface to the outermost surface of the steel, and includes the thickness of masonry face shells, mortar, and grout. The following minimum cover requirements apply when masonry is designed in accordance with the provisions of the ACI 530/ASCE 5/TMS 402 (Ref. 8) and ACI 530.1/ASCE 6/TMS 602 (Ref. 7):

- For masonry exposed to earth or weather, the minimum cover shall be 2 inches.
- For masonry not exposed to earth or weather, the minimum cover shall be  $1\frac{1}{2}$  inch.

Reinforcing bar placement tolerances are:

- When the distance from the centerline of steel to the compression face of the masonry wall is less than 8 inches, the placement tolerance for the reinforcing steel is  $\pm\frac{1}{2}$  inch measured perpendicular to the face of the wall.
- When the distance from the centerline of steel to the compression face of the masonry wall is greater than 8 inches but less than 24 inches, the placement tolerance for the reinforcing steel is  $\pm 1$  inch measured perpendicular to the face of the wall.
- For the longitudinal placement (measured parallel to the face of the wall) of the vertical reinforcing bars, the tolerance is  $\pm 2$  inches.

### ***8.5.2 Tolerances for Constructing Masonry***

The *Specification for Masonry Structures* (Ref. 7) specifies tolerances for concrete masonry construction. Although poor tolerances can result in an aesthetically unpleasing structure, the tolerances provided

are primarily derived to avoid structurally impairing a wall because of improper placement.

1. The dimension of elements in cross section or elevation shall not differ by more than  $-\frac{1}{4}$  inch to  $+\frac{1}{2}$  inch.
2. The thickness of mortar bed joints shall not differ by more than  $\pm\frac{1}{8}$  inch.
3. The thickness of mortar head joints shall not differ by more than  $-\frac{1}{4}$  inch to  $+\frac{3}{8}$  inch.
4. Bed joints and the top surfaces of bearing walls shall be level within  $\pm\frac{1}{4}$  inch in 10 feet or  $\pm\frac{1}{2}$  inch maximum.
5. The variation from plumb shall not exceed  $\pm\frac{1}{4}$  inch in 10 feet,  $\pm\frac{3}{8}$  inch in 20 feet, or  $\pm\frac{1}{2}$  inch maximum.
6. Elements shall be true to a line within  $\pm\frac{1}{4}$  inch in 10 feet,  $\pm\frac{3}{8}$  inch in 20 feet, and  $\pm\frac{1}{2}$  inch maximum.
7. The alignment of columns and bearing walls (bottom versus top) shall be within  $\pm\frac{1}{2}$  inch maximum.
8. Elements shall be located as indicated in plan within  $\pm\frac{1}{2}$  inch in 20 feet or  $\pm\frac{3}{4}$  inch maximum.
9. Elements shall be located as indicated in elevation within  $\pm\frac{1}{4}$  inch for each story height or  $\pm\frac{3}{4}$  inch maximum.

### ***8.5.3 Tolerances for Concrete Footings***

Standard Specifications for Tolerances for Concrete Construction and Materials, ACI 117 (Ref. 11), contains the following tolerances for concrete footings:

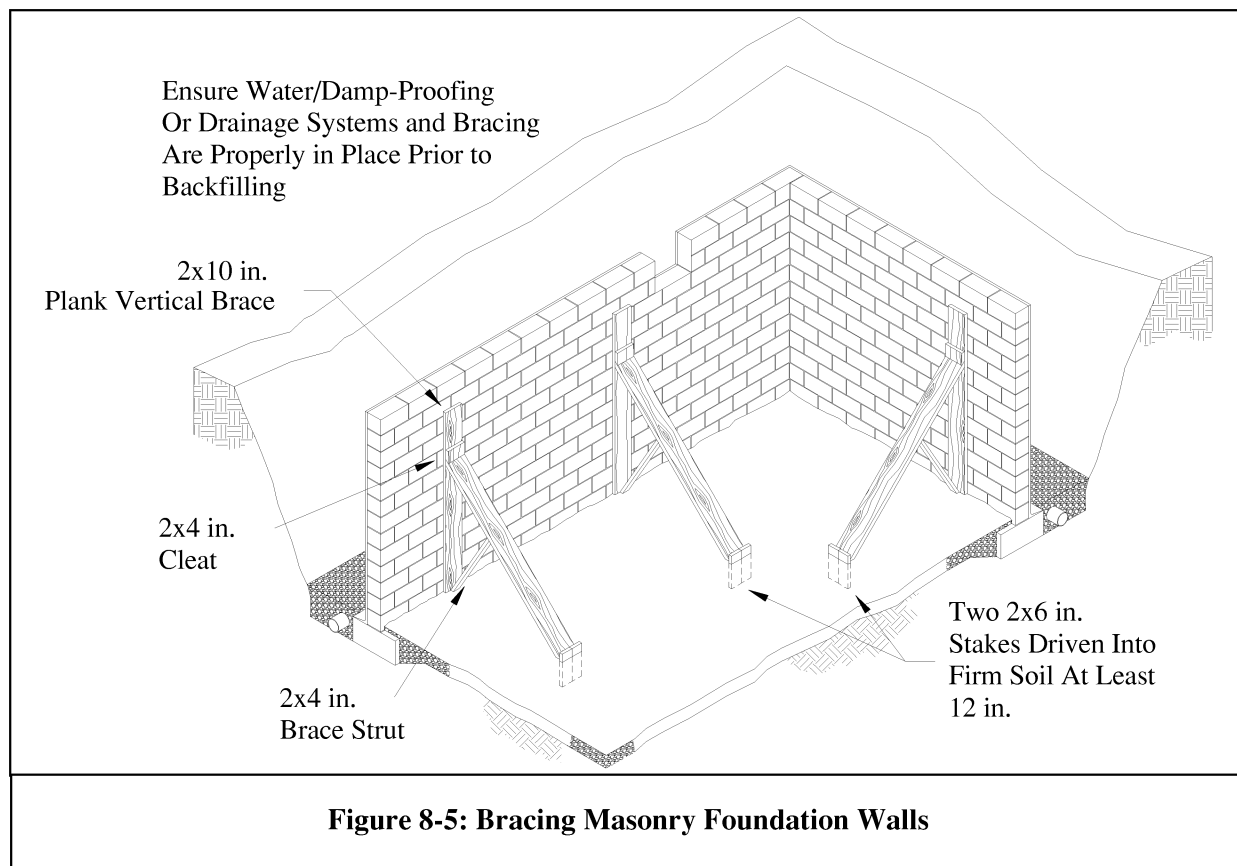
Lateral alignment of footings supporting masonry:

- As cast to the center of gravity as specified; 0.02 times width of footing in direction of misplacement but not more than  $\frac{1}{2}$  inch.
- Level alignment of footings supporting masonry is  $\frac{1}{2}$  inch.
- Cross-sectional dimensions of footings
  - Horizontal dimension of formed members  $+2$  inches to  $-\frac{1}{2}$  inch.
  - Horizontal dimension of unformed members cast against soil;
    - 2 ft or less...  $+3$  inches to  $-\frac{1}{2}$  inch.
    - greater than 2 feet but less than 6 feet...  $+6$  inches to  $-\frac{1}{2}$  inch.
    - over 6 feet...  $+12$  inches to  $-\frac{1}{2}$  inch.
  - The vertical dimension (thickness) of a footing shall be within  $-5$  percent.

### **8.6 Backfilling**

One of the most crucial aspects of basement construction is how and when to backfill so that cracking of basement walls is prevented. Under most circumstances, walls should always be properly braced or have the first floor in place prior to backfilling. Otherwise, a wall, which is designed to be supported at the top, may crack or even fail from the large soil pressures.

Figure 8-5 shows one bracing scheme that has been widely used for residential basement walls. More substantial bracing may be required for high walls or large backfill pressures (Ref. 18).



The need for special bracing of partially completed construction should be considered whenever inclement weather or other factors delay the construction. Heavy rains have on occasion caused collapse of the side slopes of excavations or earth slides resulting in filling of the excavation adjacent to the basement walls with earth and water to a point where the lateral pressures on the walls have been sufficient to cause failure. In areas where heavy rains are not unusual and would channel considerable surface water towards the foundation walls during construction, it is a practice of some contractors to omit an occasional block close to the bottom of the wall. In the event of flooding of the excavated area adjacent to the walls, these openings prevent the water level from building up to excessive heights on one side. The pressure on the inside and outside of the walls is thus equalized and the danger of wall failure due to excessive lateral pressures reduced. The missing units

are installed in the wall after the lateral support for the top of the wall is in place and prior to backfilling.

The drainage and waterproofing systems should always be inspected prior to backfilling to insure they are adequately placed. Any questionable workmanship or materials should be repaired at this stage since repairs are difficult and expensive after backfilling.

The backfill material should preferably be drainable soil that is free of large stones, construction debris, organic materials, and frozen earth. Saturated soils, especially saturated clays should generally not be used as backfill materials since wet materials significantly increase the hydrostatic pressure on the walls.

Backfill materials should be placed in several lifts and each layer should be

compacted with small mechanical tampers. Care should be taken when placing the backfill materials so as to prevent damaging the drainage, water resisting membrane, or exterior insulation systems. Sliding boulders and soil down steep slopes should thus be avoided since the high impact loads generated can damage not only the drainage and waterproofing systems but the wall as well. Likewise, heavy equipment should not be operated within about 3 feet of any basement wall system.

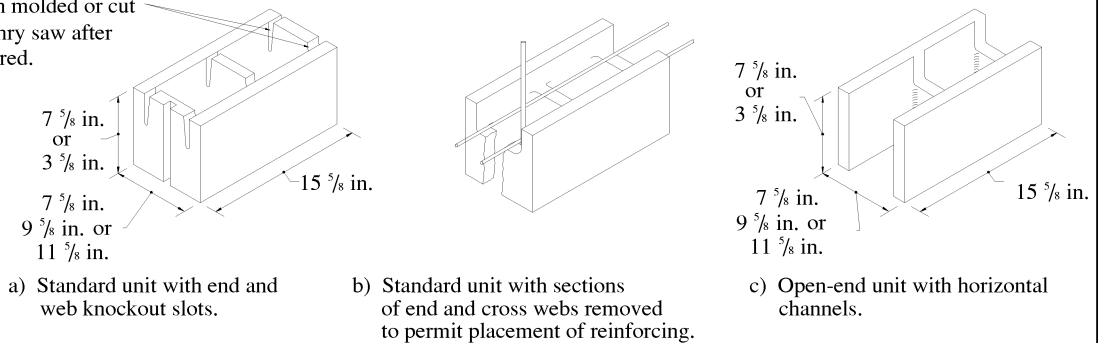


**Figure 8-6: Bracing of Masonry Foundation**

The top 4 to 8 inches of backfill materials should be low permeability soil so rainwater is absorbed slowly into the backfill or diverted by runoff. Grade should be sloped

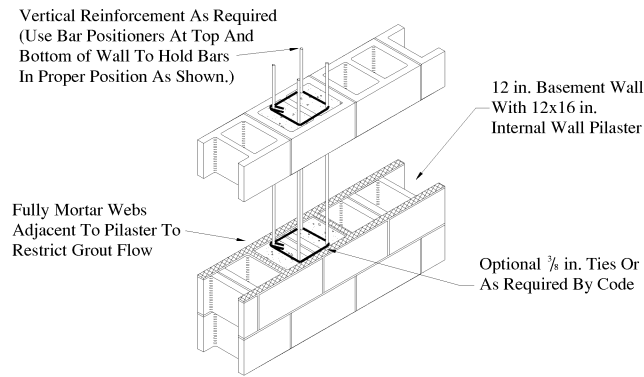
away from the basement at least 6 inches within 10 feet from the house. If the ground naturally slopes toward the home, a shallow trench called a swale can be installed to direct runoff away from the building. (Refer to Chapter 4 for additional information on water penetration resistance.)

NOTE: Knockout slots may be cast in unit when molded or cut out with a masonry saw after unit has been cured.

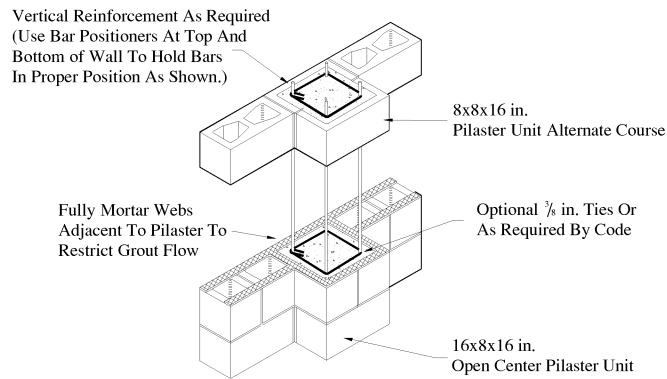


**Figure 8-7: Knock-out and Bond Beam Units**

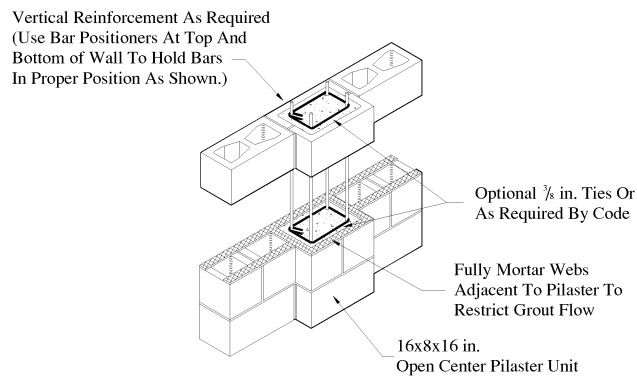




12 x 16 in.  
Internal Wall Pilasters

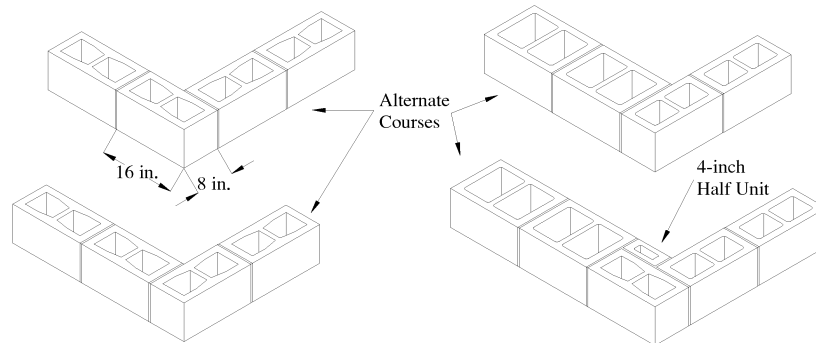


16 x 16 in.  
Open Center Pilasters



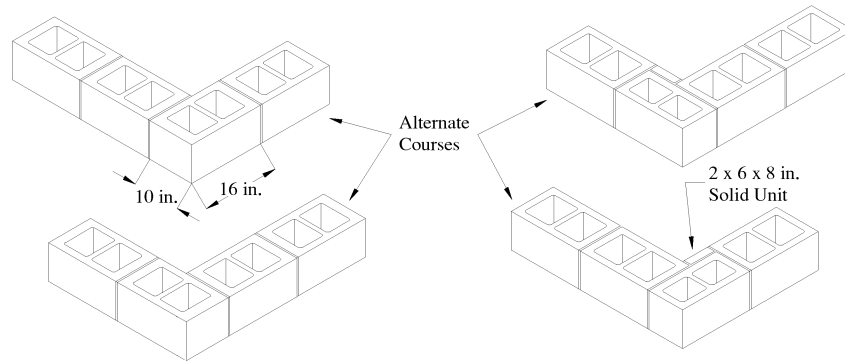
12 x 16 in.  
Open Center Pilasters

**Figure 8-8: Pilaster Details**



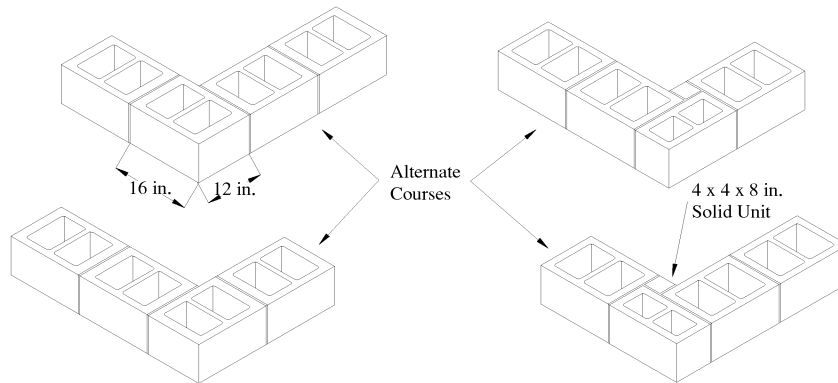
(A) 8-inch to 8-inch  
Wall Corner Detail

(B) Alternate 8-inch to  
12-inch Wall Corner Detail



(C) 10-inch to 10-inch  
Wall Corner Detail

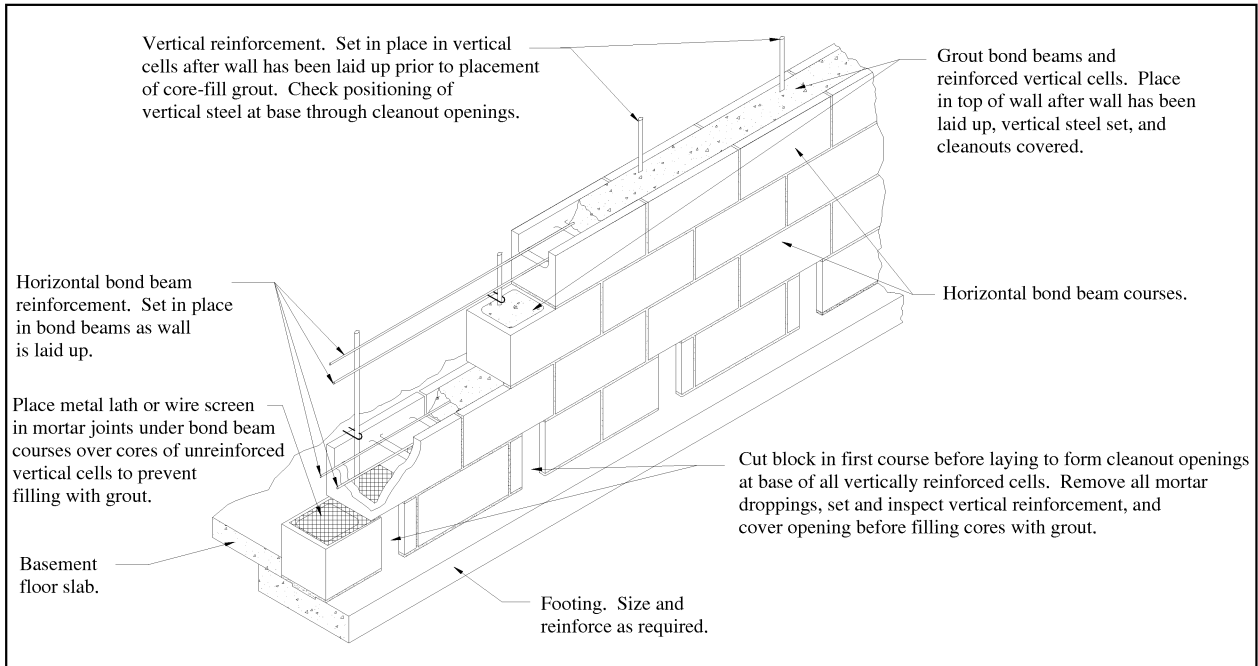
(D) Alternate 10-inch to  
10-inch Wall Corner Detail



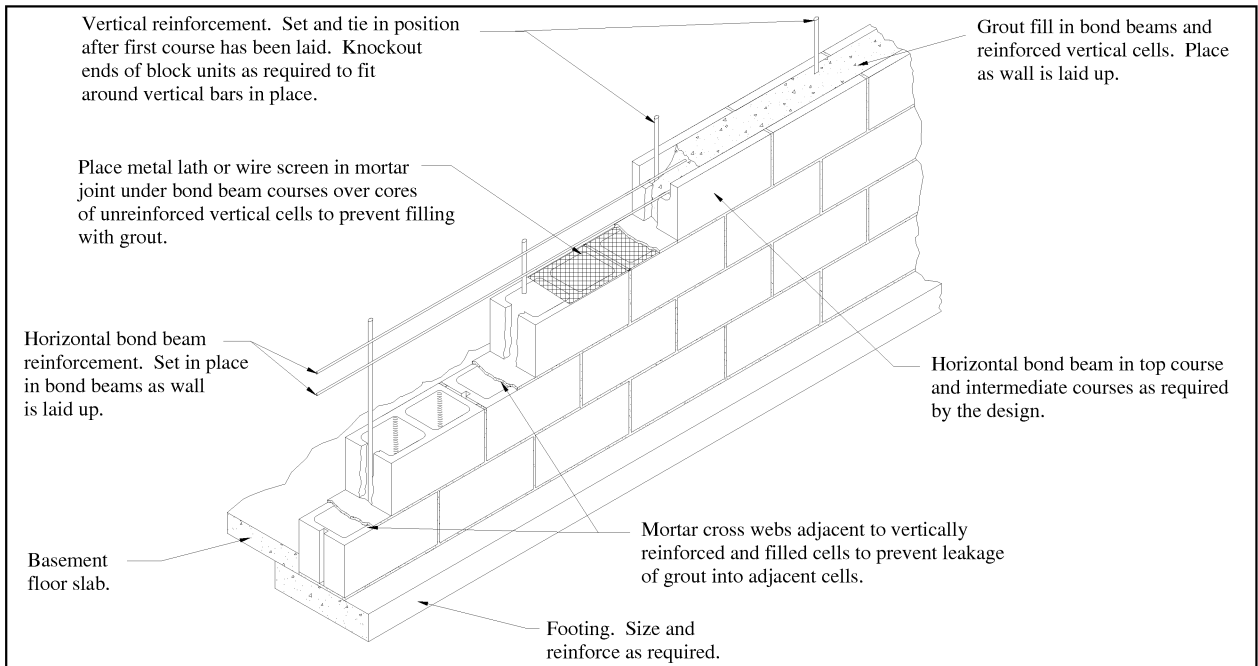
(E) 12-inch to 12-inch  
Wall Corner Detail

(F) Alternate 12-inch to  
12-inch Wall Corner Detail

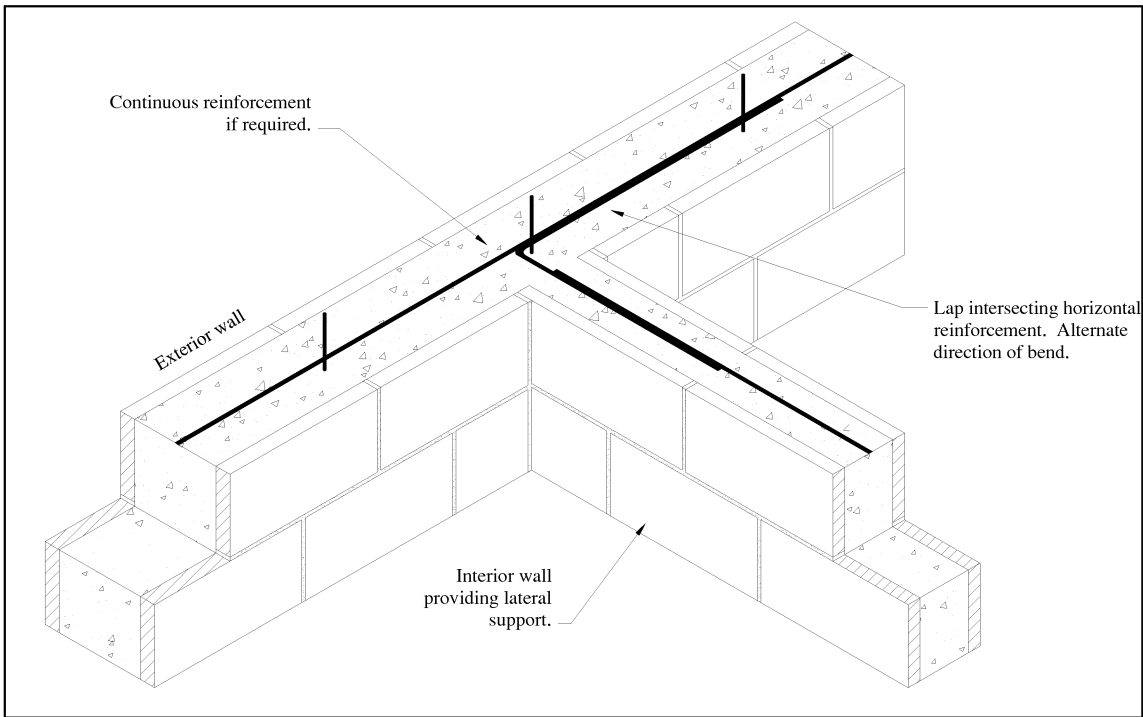
**Figure 8-9: Standard Corner Details**



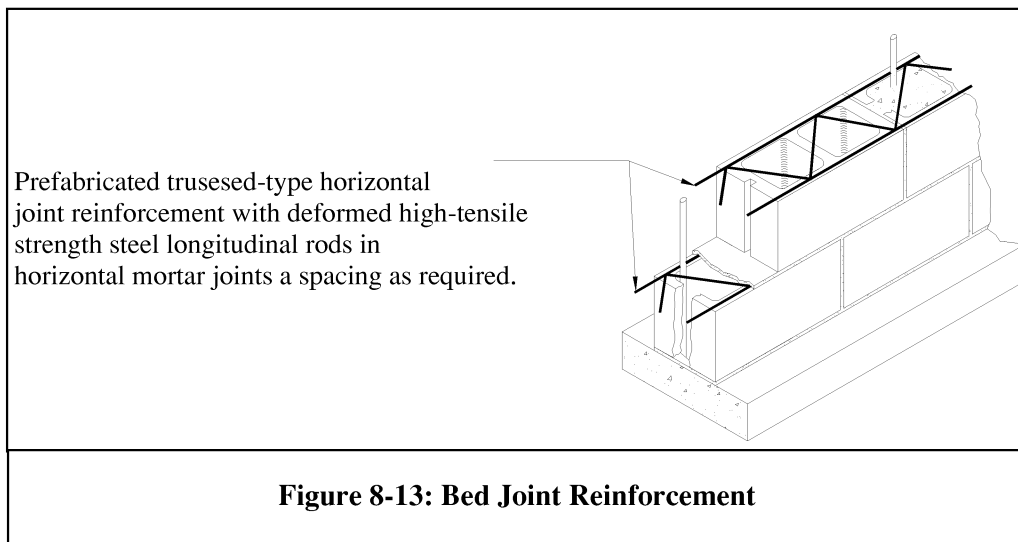
**Figure 8-10: Reinforced Concrete Masonry Construction**



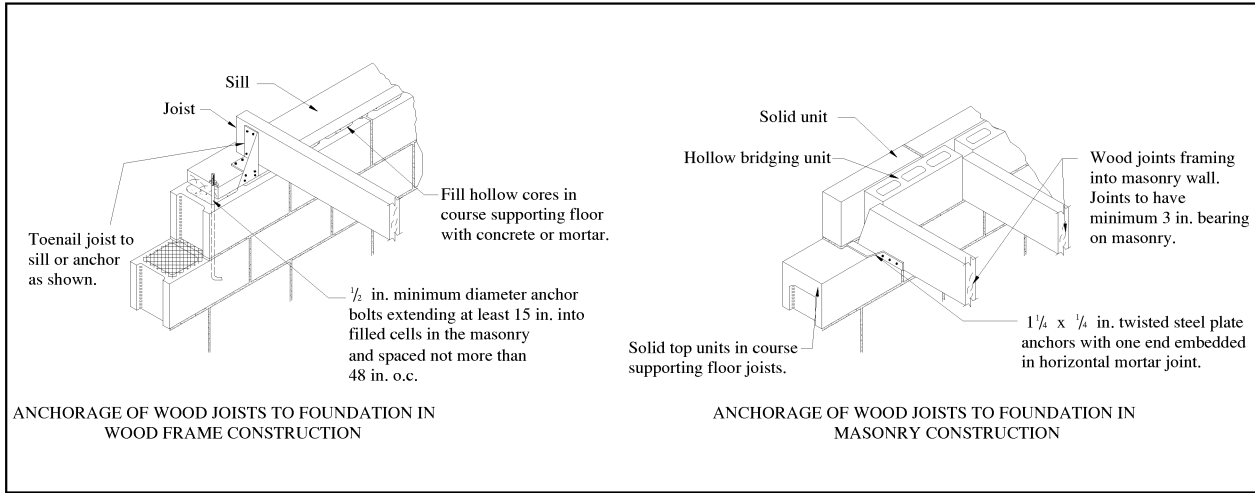
**Figure 8-11: Reinforced Concrete Masonry Construction**



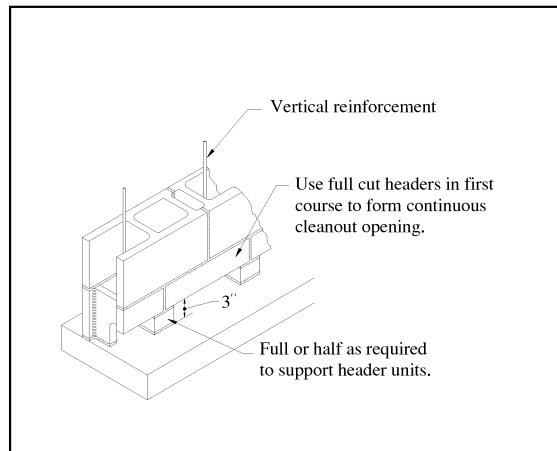
**Figure 8-12: Intersecting Wall Detail**



**Figure 8-13: Bed Joint Reinforcement**



**Figure 8-14: Anchorage of Joist to Foundation Walls**



**Figure 8-15: Cleanout Detail**

# **Appendix**

Appendix A – Metric Conversions

Appendix B – Definitions

Appendix C – Notations

References

## Appendix A Metric Conversions

Quantity	Inch-Pound Units	Metric Units	Multiply Inch-Pound Units by:
Length	mi	km	1.609344*
	ft	m	0.3048*
	ft	mm	304.8*
	in.	cm	2.54*
	in.	mm	25.4*
Area	yd <sup>2</sup>	m <sup>2</sup>	0.83612736*
	ft <sup>2</sup>	m <sup>2</sup>	0.09290304*
	in. <sup>2</sup>	mm <sup>2</sup>	645.16*
Volume	yd <sup>3</sup>	m <sup>3</sup>	0.7645549
	ft <sup>3</sup>	m <sup>3</sup>	0.0283168
	in. <sup>3</sup>	mm <sup>3</sup>	16,387.064*
Mass	ton	Mg	0.9071847
	lb	kg	0.4535924
Density	lb/ft <sup>3</sup>	kg/m <sup>3</sup>	16.01846
Force	lb	N	4.448222
Force/Unit Length	lb/ft	N/m	14.593904
	lb/in.	N/mm	0.1751269
Force/Unit Area	psf	Pa	47.88026
	psi	MPa	0.00689476
	psf	kPa	0.04788026

\*Denotes exact conversion.

## Appendix B Definitions

### **“A” block**

Hollow masonry units with one end closed by a cross web and the opposite end open or lacking an end cross web, typically forming two cells when laid in running bond. (See “open end block”.)

### **Absorption**

The amount of water that a solid or hollow concrete masonry unit absorbs when immersed in water for a specified length of time; expressed as a percentage of the dry unit weight or as pounds of water per cubic foot of cement. Usually, the lower the absorption, the more dense the masonry unit.

### **Accelerator**

A liquid or powder ingredient added to a cementitious paste to speed hydration and promote early strength development. Accelerator materials include calcium chloride and compositions predominately of calcium chloride. Care should be taken when using accelerators as they promote corrosion of any reinforcing steel present.

### **Actual dimension**

(See “dimensions, actual”.)

### **Adhesion (bond)**

The physical binding between masonry units, mortar, and reinforcing steel.

### **Admixtures**

Ingredients, that when added, impart special properties to mortar or grout. Traditional materials other than water, aggregates, masonry lime, masonry cement, and portland cement used as an ingredient of concrete, mortar, or grout and added to the mix immediately before or during mixing are admixtures.

### **Aggregate gradation**

(See “gradation”.)

### **Aggregates**

An inert granular material such as natural sand, manufactured sand, gravel, crushed stone, vermiculite, perlite, and air cooled blast furnace slag, which, when bound together into a conglomerate mass by a cementitious matrix, forms concrete, grout, or mortar.

### **Air entraining**

The capability of a material or process to develop a system of microscopic bubbles of air in a cementitious paste to increase the workability or durability of the resulting product. Some admixtures act as air entraining agents.

### **Anchor**

Metal rod, bolt, or strap used to secure masonry to other structural elements.

### **Angle iron**

A structural steel section that has two legs joined at 90 degrees to one another; used as a lintel to support masonry over openings such as doors or windows in lieu of a masonry arch or reinforced masonry lintel. Sometimes referred to as a relieving angle.

### **Arch**

A vertically curved compressive structural member spanning openings or recesses; may also be built flat by using special masonry shapes or specially placed units.

### **Area, gross cross-sectional**

The area delineated by the out-to-out dimensions of masonry in the plane under consideration.



**Area, net cross-sectional**

The area of masonry units, grout, and mortar crossed by the plane under consideration removing all voids such as empty cells from the load-carrying surface.

**Autoclave**

In the production of concrete masonry units, a type of curing system chamber that utilizes super heated steam under pressure to promote or enhance specific properties of manufactured units.

**Axial load**

The load exerted on top of a wall or column acting parallel to the element's vertical axis and located at the centroid point or center of the wall or column mass. Eccentric loads (which also act vertically) are not located or calculated to occur in the exact center of the mass such as axial loads.

**Backing**

The surface to which a non-structural finish material is secured. The backing may be concrete, masonry, steel framing, or wood framing.

**Backup**

The part of a multi-wythe masonry wall behind the exposed facing.

**Beam**

A structural member designed to resist flexure.

**Bearing partition**

An interior wall that supports a vertical load in addition to its own weight.

**Bed joint**

The horizontal layer of mortar on which a masonry unit is laid.

**Bedded area**

The area of the surface of a masonry unit which is in contact with mortar in the plane of the joint.

**Block**

A concrete masonry unit larger than brick-sized units.

**Block machine**

Equipment used to mold, consolidate, and compact shapes when manufacturing concrete masonry units.

**Bond**

(1) The arrangement of units to provide strength, stability, or a unique visual effect created by laying units in a prescribed pattern. (2) Adhesive or interlocking forces between mortar or grout and masonry units or reinforcement. (3) To connect wythes or masonry units. (4) Tying various parts of a masonry wall by lapping units one over another or with metal ties or reinforcing.

**Bond beam**

(1) The course or courses of masonry units reinforced with longitudinal bars and designed to take the longitudinal flexural and tensile forces that may be induced in a masonry wall. (2) A horizontal grouted element within masonry in which reinforcement is embedded.

**Bond beam block**

A hollow unit with depressed web portions to form a continuous channel, or channels, for reinforcing steel and grout. U-block are sometimes used to form bond beams, especially over openings.

**Bond breaker**

A material used to prevent adhesion between two surfaces.

**Bond, running**

Placing of units in successive courses so that the head joints overlap the units in the course immediately below. Placing head joints centered over the unit below is called center or half bond, while lapping 1/3 or 1/4 is called third bond or quarter bond, respectively. The Code (Ref. 8) considers masonry to be in running bond when the head joints in successive courses are horizontally offset at least one-quarter the unit length.

**Bond, stack**

Units laid so no overlap occurs; headjoints form a continuous vertical line. Also called plumb joint bond, straight stack, jack bond, jack-on-jack, and checkerboard bond. The Code (Ref. 8) considers all masonry not laid in running bond (headjoints in successive courses, horizontally offset at least one-quarter the unit length) as stack bond.

**Bond strength**

Resistance to separation of mortar from concrete masonry units and of mortar and grout from reinforcing steel and other materials with which it is in contact.

**Bonder**

A masonry unit that overlaps two or more adjacent wythes of masonry to bind or tie them together. Also called a header bond.

**Bonding**

(See “bond”.)

**Brick**

A solid or hollow manufactured masonry unit, usually formed into a small rectangular prism.

**Cantilever**

A structural member supported at only one end, which projects from a support.

**Cap**

Masonry units laid on top of a finished wall.

**Cap block**

A solid flat slab used as a capping unit for parapet and garden walls. Also used for stepping stones, patios, veneering, etc.

**Carbonation**

A reaction between carbon dioxide and calcium compounds, especially in cement paste, mortar, or concrete, to produce calcium carbonate.

**Caulking**

Sealing joints in masonry with a resilient compound such as a silicone material.

**Cavity wall**

A multi-wythe noncomposite masonry wall with a continuous air space within the wall (with or without insulation), that is tied together with metal ties.

**Cavity wall tie**

A rigid corrosion-resistant metal tie that bonds two wythes of a cavity wall.

**Cell**

(1) The holes in hollow concrete masonry units commonly called cores. (2) A hollow space within a concrete masonry unit formed by the face shells and webs.

**Cement**

(1) A material or mixture of materials (without aggregates) which, when in a plastic state, possesses adhesive and cohesive properties and hardens in place. (2) A powdered substance made of burned lime and clay mixed with water and sand to make mortar or mixed with water, sand, and gravel to make concrete; the mixture hardens due to a chemical reaction during curing.

**Cementitious material**

When proportioning masonry mortars, the following are considered cementitious material: portland cement, blended hydraulic cement, masonry cement, lime putty, and hydrated lime.

**Cementitious material, Hydraulic**

An inorganic material or a mixture of inorganic materials, that sets and develops strength by chemical reaction with water.

**Channel block**

A hollow unit with depressed web portions to form a continuous channel for reinforcing steel and grout. (See bond beam units.)

**Cinder**

An aggregate, sometimes used in the manufacture of concrete masonry units, usually produced from the combustion of coal.

**Cleanout/cleanout holes**

(1) An opening in the first course of masonry for removing mortar droppings prior to grout placement in grouted masonry.

**Coatings**

Material applied to a surface by brushing, dipping, mopping, spraying, troweling, etc., to preserve, protect, decorate, seal, or smooth the substrate.

**Cold weather construction**

Procedures used in constructing masonry when ambient air temperature or masonry unit temperature is below 40°F (4.4°C).

**Collar joint**

The vertical longitudinal spaces between wythes of masonry or between a masonry wythe and back up construction, which is permitted to be filled with, mortar or grout.

**Color pigment**

A powdered substance that, when blended with a liquid vehicle, gives the matrix its coloring.

**Column**

(1) In structures, a relatively long, slender structural compression member such as a post, pillar, or strut. Usually vertical, a column supports a load that acts in the direction of its longitudinal axis. (2) For the purposes of design, an isolated vertical member whose horizontal dimension measured at right angles to the thickness does not exceed 3 times its thickness and whose height is at least 3 times its thickness.

**Composite action**

Transfer of stress between components of a member designed so that in resisting loads, the combined components act together as a single member.

**Compressive strength**

The maximum compressive load that a specimen will support divided by the cross-sectional area of the specimen.

**Compressive strength of masonry**

Maximum compressive force resisted per unit of net cross-sectional area of masonry, determined by the testing of masonry prisms or a function of individual masonry units, mortar and grout in accordance with the provisions of ACI 530.1/ASCE 6/TMS 602 (Ref. 7).

**Concrete**

A composite material that consists essentially of a binding medium within which are embedded particles or fragments of aggregate, usually a combination of fine aggregate and coarse aggregate. In portland-cement concrete, the binder is a mixture of portland cement and water.

**Concrete block**

A hollow or solid unit consisting of portland cement and suitable aggregates combined with water with or without the inclusion of other materials. Larger in size than a concrete brick.

**Concrete brick**

A hollow or solid unit consisting of portland cement and suitable aggregates combined with water with or without the inclusion of other materials. Smaller in size than a concrete block.

**Concrete masonry unit**

Hollow or solid masonry unit made from cementitious materials, aggregates and water, usually formed into a rectangular prism.

**Connector**

A mechanical device for securing two or more pieces, parts, or members together, including anchors, wall ties, and fasteners.

**Connector, anchor**

Device used to attach masonry to other structural elements.

**Connector, fastener**

Device used to attach other materials to masonry.

**Connector, tie**

Metal device used to join wythes of masonry in a multiwythe wall.

**Control joint**

(1) A continuous unbonded masonry joint that is formed, sawed, or tooled in a masonry structure to regulate the location and amount of cracking and separation resulting from the dimensional change of different parts of the structure, thereby avoiding the development of high stresses.

**Coping**

The materials or masonry units used to form a cap or a finish on top of a wall, pier, chimney, or pilaster to protect the masonry below from water penetration. Commonly extended beyond the wall face and cut with a drip.

**Coping block**

A solid concrete masonry unit for use as the top and finished course in wall construction.

**Core**

(1) The molded open space in a concrete masonry unit. (2) A hollow space within a concrete masonry unit formed by the face shells and webs. (3) Also called a cell.

**Corrosion**

Destruction of metal by chemical, electrochemical, or electrolytic reaction with its environment.

**Corrosion resistant**

Material that is treated or coated to retard harmful oxidation or other corrosive action. An example is steel galvanized after fabrication.

**Course**

A layer (range) of masonry units running horizontally in a wall or, much less commonly, curved over an arch.

**Crack control**

Methods used to control the extent, size, and location of cracking in masonry including incorporating reinforcing steel, control joints, and dimensional stability of masonry materials.

**Cracking**

A complete or incomplete separation of masonry into two or more parts produced by breaking or fracturing.

**Cross-sectional area, gross**

The total area of a section perpendicular to the direction of the load, including areas within cells and within reentrant spaces unless these spaces are to be occupied in the masonry by portions of adjacent masonry.

**Cross-sectional area, net**

The gross cross-sectional area of a section minus the area of ungrouted cores, open spaces, or any other area devoid of masonry. The cross sectional area of the grooves in scored masonry units is not deducted from the gross cross-sectional area to obtain the net cross-sectional area.

**Culls**

Masonry units that do not meet the standards or specifications and therefore have been rejected.

**Curing**

The maintenance of proper conditions of moisture and temperature during initial set to develop a required strength and reduce shrinkage in products containing portland cement.

**Curtain wall**

(See “wall, curtain”.)

**Damp-proofing**

Treatment of masonry to retard the passage or absorption of water or water vapor, either by application of a suitable coating to exposed surfaces or by use of a suitable admixture or treated cement.

**Damp check**

An impervious horizontal layer to prevent vertical penetration of water in a wall consisting of either a course of solid masonry, metal, or a thin layer of asphaltic or bituminous material. Generally near grade to prevent upward migration of moisture by capillary action.

**Density**

The ratio of the mass of a concrete masonry unit to its volume.

**Diaphragm**

A roof or floor system designed to transmit lateral forces to shear walls or other lateral load resisting elements.

**Dimension, actual**

The real measured size of a concrete masonry unit, not accounting for any adjacent or expected thickness of mortar joints.

**Dimension, nominal**

A nominal dimension is equal to a specified dimension plus an allowance for the joints with which the units are to be laid. Nominal dimensions are usually stated in whole numbers. Width (thickness) is given first, followed by height and then length.

**Dimension, specified**

The dimensions specified for the manufacture or construction of masonry, masonry units, joints or any other component of a structure. Unless otherwise stated, all calculations shall be made using or based on specified dimensions.

**Dowels**

Straight metal bars used to connect two sections of masonry.

**Drip**

Groove or slot cut beneath and slightly behind the forward edge of a projecting unit or element, such as a sill, lintel, or coping, to cause rainwater to drip off and prevent it from penetrating the wall.

**Drying shrinkage**

The change in linear dimension of a masonry wall due to drying.

**Dry stack**

Masonry work laid without mortar.

**Eccentricity**

The distance between a vertical load reaction and the centroidal axis of the masonry element under load.

**Effective Height**

The height of a member to be assumed for calculating the slenderness ratio.

**Effective Thickness**

The thickness of a member to be assumed for calculated the slenderness ratio.

**Efflorescence**

A deposit of encrustation of soluble salts (generally white), that may form on the surface of stone, brick, concrete, or mortar when moisture moves through, and evaporates on, the masonry. Often caused by free alkalies leached from mortar, grout, adjacent concrete, or in clays and deposited on the surface of the masonry.

**Equivalent thickness**

The solid thickness to which a hollow unit would be reduced if the material in the unit were recast into a unit with the same face dimensions but without voids. The percent solid volume multiplied by the actual width divided by 100.

**Expansion bolt**

An anchoring device (based on a friction grip) in which an expandable socket expands, causing a wedge action, as a bolt is tightened into it.

**Exterior wall**

(See “wall, exterior”.)

**Face**

(1) The exposed surface of a wall or masonry unit. (2) The surface of a wall or

masonry unit. (3) The surface of a unit designed to be exposed in the finished masonry.

**Face shell**

The side (typically exposed) of a hollow concrete masonry unit.

**Face shell bedding**

Mortar is applied only to the horizontal face of the face shells of hollow masonry units and in the head joints to a depth equal to the thickness of the face shell.

**Facing**

Any material forming a part of a wall used as a finished surface.

**Fire resistance**

A rating assigned to walls indicating the length of time a wall performs as a barrier to the passage of flame, hot gases and heat when subjected to a standard fire and hose stream test in accordance with ASTM E 119 (Ref. 5-E).

**Fire wall**

Any wall, which subdivides a building, so as to resist the spread of fire.

**Flashing**

A thin impervious material placed in mortar joints and through air spaces in masonry to prevent water penetration and to provide water drainage.

**Fluted block**

Block with grooves that are in a visual pattern. For example, the grooves may simulate raked joints. Also referred to as scored block.

**Fly ash**

The finely divided residue resulting from the combustion of ground or powdered coal. Sometimes used as a cementitious material.

**Footing**

A structural element that transmits loads directly to the soil.

**Foundation wall**

(See “wall, foundation”.)

**Freeze-thaw**

Freezing and thawing of moisture in materials and the resultant effects on these materials and on structures of which they are a part or with which they are in contact.

**Full mortar bedding**

Where mortar is applied to the entire horizontal face of the masonry unit.

**Furring**

A method of finishing the interior face of a masonry wall to provide space for insulation, to prevent moisture transmittance, or to provide a smooth or plane surface for finishing.

**Gradation**

The particle size distribution of aggregate as determined by separation with standard screens. Gradation of aggregate is expressed in terms of the individual percentages passing standard screens. Sieve analysis and screen analysis are synonymous when referring to gradation of aggregate.

**Ground block**

A concrete masonry unit in which the exposed surface is ground to a smooth finish.

**Grout**

Mixture of cementitious material and aggregate to which sufficient water is added to produce desired placing consistency without segregation of the constituents; or the hardened equivalent of such mixtures.

**Grout lift**

An increment of grout height within the total grout pour. A grout pour consists of one or more grout lifts.

**Grout pour**

The total grouted height of masonry to be grouted prior to erection of additional masonry. A grout pour consists of one or more grout lifts.

**Grouted masonry**

(1) Concrete masonry construction composed of hollow units where hollow cells are filled with grout, or multi-wythe construction in which space between wythes is solidly filled with grout. (2) Masonry construction made with solid masonry units in which the interior joints and voids are filled with grout.

**Grouting, high lift**

The technique of grouting masonry in lifts for the full height of the wall.

**Grouting, low lift**

(1) The technique of grouting as the wall is constructed. (2) The technique of grouting as the wall is constructed, usually to scaffold or bond beam height, but not greater than 4 feet.

**Gypsum**

Soft mineral consisting of hydrous calcium sulfate. The raw material from which plaster is made (by heating).

**“H” block**

Hollow masonry units with both ends open forming an “H” in cross section.

**Head joint**

Vertical mortar joint placed between masonry units within the wythe at the time the masonry units are laid.

**Height of wall**

The vertical distance from the foundation wall, or other similar intermediate support of such wall, to the top of the wall, or the vertical distance between intermediate supports.

**Height-thickness ratio**

The height of a masonry wall divided by its nominal thickness. The thickness of cavity walls is taken as the overall thickness minus the width of the cavity.

**High lift grouting**

(See “grouting, high lift”).

**Hollow-masonry unit**

A masonry unit whose net cross-sectional area in any plane parallel to the bearing surface is 75 percent or less of its gross cross-sectional area measured in the same plane.

**Hot weather construction**

Procedures used in constructing masonry when ambient air temperature exceeds 100°F (37.8°C) or temperature exceeds 90°F (32.2°C) with a wind speed greater than 8 mph (13 km/h).

**Inspection**

Observation to verify that the masonry construction meets the requirements of the applicable design standards and contract documents.

**Jamb block**

A block specially formed for the jamb of windows or doors, generally with a vertical slot to receive window frames, etc.

**Joint**

The surface at which two members joint or butt. If they are held together by mortar, the mortar-filled aperture is the joint.

**Joint reinforcement**

Steel wires placed in the mortar joint (over the face shells in hollow masonry) and having cross wires welded between them at regular intervals.

**Lap**

(1) The distance two bars overlap when forming a splice. (2) The distance one masonry unit extends over another.

**Lap Splice**

The connection between reinforcing steel generated by overlapping the ends of the reinforcement.

**Lateral support**

Means whereby structural members are braced in the horizontal span by columns, buttresses, pilasters, cross walls, or in the vertical span by beams, floor, or roof construction.

**Lateral support of walls**

Method whereby walls are braced in the vertical span by beams, floors, or roofs, or in the horizontal span by columns, pilasters, buttresses, or cross walls.

**Lightweight aggregate**

Aggregate of low density, such as expanded or sintered clay, shale, slate, diatomaceous shale, perlite, vermiculite, slag, natural pumice, volcanic cinders, diatomite, sintered fly ash, or industrial cinders.

**Lightweight concrete masonry unit**

A unit whose oven-dry density is less than 105 lb/ft<sup>3</sup> (1680 kg/m<sup>3</sup>).

**Lime**

Calcium oxide (CaO), a general term for the various chemical and physical forms of quicklime, hydrated lime, and hydraulic hydrated lime.



**Lintel**

A beam placed or constructed over an opening in a wall to carry the superimposed load.

**Lintel block**

A masonry unit consisting of one core with one side open. Usually placed with the open side up, like a trough, to be reinforced and grouted to form a continuous beam.

**Loadbearing**

A structural system or element designed to carry loads in addition to its own dead load.

**Loads, allowable**

The permitted and projected safe load capacity through testing or calculated for a given structural element or combination of elements, including an acceptable safety factor for given material.

**Low lift grouting**

(See “grouting, low lift”.)

**Maintenance**

The repair effort required to limit deterioration of an element's physical appearance or structural integrity.

**Masonry**

An assemblage of masonry units and mortar with or without grout and reinforcing steel.

**Masonry cement**

(1) A mill-mixed cementitious material to which sand and water is added to make mortar. (2) Hydraulic cement produced for use in mortars for masonry construction where greater plasticity and water retention are desired than is obtainable by the use of portland cement alone. Such cements always contain one or more of the following materials: portland cement, portland-pozzolan cement, natural cement, slag cement, hydraulic lime, and usually contain

one or more of the following: hydrated lime, pulverized limestone, chalk, talc, pozzolan, clay or gypsum; many masonry cements also include air-entraining and water-repellent additions.

**Masonry cement mortar**

Mortar produced using a premixed masonry cement.

**Masonry unit**

Natural or manufactured building units of burned clay, concrete, stone, glass, gypsum, etc.

**Masonry veneer**

(See “veneer, masonry”.)

**Medium weight concrete masonry unit**

A unit whose oven-dry density is at least 105 lb/ft<sup>3</sup> (1680 kg/m<sup>3</sup>) and less than 125 lb/ft<sup>3</sup> (2000 kg/m<sup>3</sup>).

**Metrics**

The Modern Metric System (SI) is the standard international system of measurement, and the system that has been mandated for use in all United States Federal Buildings.

**Mix design**

The proportions of ingredients to produce mortar, grout, or concrete.

**Mixer**

A machine employed for blending the constituents of concrete, grout, mortar, or other mixtures.

**Modular coordination**

Designating masonry units, door and window frames, and other construction components that fit together during construction.

**Modular design**

Constructed with standardized units or dimensions for flexibility and variety in use.

**Modulus of elasticity**

Ratio of normal stress to corresponding strain for tensile or compressive stresses below proportional limit of the material.

**Moisture content**

The amount of water contained at the time of sampling expressed as a percentage of the total absorption.

**Mortar**

A plastic mixture of cementitious materials, fine aggregate and water used to bond masonry or other structural units.

**Mortar bed**

A layer of mortar used to seat a masonry unit.

**Mortar bond**

(See “bond, mortar”.)

**Mortar joint, bed**

Horizontal joint between courses of masonry units.

**Mortar joint, collar**

Vertical, longitudinal joint between masonry wythes, or between masonry wythe and backing.

**Mortar joint, head**

Vertical joint between masonry units.

**Movement joint, control**

In concrete masonry, a continuous joint or plane to accommodate shrinkage; may contain unbonded mortar or grout.

**Net area**

(See “cross-sectional area, net”.)

**Net section**

Minimum cross section of the member under consideration.

**Net cross-sectional area**

(See “cross-sectional area, net”.)

**Nominal dimension**

(See “dimension, nominal”.)

**Noncombustible**

Any material that will neither ignite nor actively support combustion in air at a temperature of 1,200°F (648.9°C) when exposed to fire.

**Normal weight concrete masonry unit**

A unit whose oven-dry density is 125 lb/ft<sup>3</sup> (2000 kg/m<sup>3</sup>) or greater.

**Open end block**

A hollow unit, with one end closed and the opposite end open, forming two cells when laid in the wall. (See “A” block and “H” block.)

**Parging**

(1) Plastering a coating of mortar, which may contain damp-proofing ingredients, over the back of masonry veneer, the face of the backup, or over underground exterior masonry. (2) The process of applying a coat of cement mortar to the back of the facing material, the face of the backing material, the face of rough masonry, and the earth side of foundation and basement walls.

**Perlite**

A volcanic glass having a perlitic structure, usually having higher water content than obsidian. Used as an insulating material and as a lightweight aggregate in concretes, mortars, and plasters.

**Pier**

An isolated column of masonry or a bearing wall not bonded at the sides to associated masonry.

**Pilaster**

A bonded or keyed column of masonry built as part of a wall. It may be flush or projected from either or both wall surfaces and has uniform cross section throughout its height. It serves as either a vertical beam or a column or both.

**Pilaster block**

Concrete masonry units designed for use in the construction of plain or reinforced concrete masonry pilasters and columns.

**Plain masonry**

Masonry constructed without steel reinforcement, except that which may be used for bonding or reducing the effects of dimensional changes due to variations in moisture content or temperature.

**Plasticizer**

A substance incorporated into a cementitious material to increase its workability, flexibility or extensibility.

**Portland cement**

Hydraulic cement produced by pulverizing clinker consisting of hydraulic calcium silicates, usually containing one or more of the forms of calcium sulfate as an interground material.

**Pozzolans**

Siliceous or a siliceous and aluminum material, which in itself possesses little or no cementitious value but will, in finely divided form and in the presence of moisture, chemically react with calcium hydroxide at ordinary temperatures to form compounds possessing cementitious properties,

**Prestressed**

Members in which a significantly controlled degree of compressive stress has been deliberately introduced.

**Prism**

A small assemblage made with masonry units and mortar and sometimes grout. Primarily used to predict the strength of full-scale masonry members.

**Prism strength**

Maximum compressive strength (force) resisted per unit of net cross-sectional area of masonry, determined by testing masonry prisms.

**Project Specifications**

The written documents which specify requirements for a project in accordance with the service parameters and other specific criteria established by the owner or his agent.

**Pumice**

Material of volcanic origin being of cellular structure and highly porous which is used as an aggregate for lightweight concrete masonry units.

**Quality assurance**

Planned system of activities whose purpose is to provide assurance that the overall quality control program is being effectively implemented. This system also involves the evaluation of corrective action initiated where necessary.

**Quality control**

Planned system of activities whose purpose is to provide a level of quality that meets the needs of the users and the use of such a system. The objective of quality control is to provide quality that is safe, adequate, dependable, and economic. The overall system involves integrating the factors of

several related steps including: the proper specification, production to meet the full intent of the specification, inspection to determine whether the resulting material, product and service is in accordance with the specifications, and review of usage to determine necessary revision to the specifications.

**R-value**

The thermal resistance that is an indication of the heat flow through a material.

**Radon**

A gaseous element produced by the radioactive decay of radium.

**Rain penetration**

Water migrating into a material.

**Raked joint**

A mortar joint where  $\frac{1}{4}$  inch (6 mm) to  $\frac{1}{2}$  inch (13 mm) of mortar is removed from the outside of the joint.

**Reinforced beams**

Structural member designed primarily to resist flexure.

**Reinforced column**

A vertical structural member in which both the steel and masonry resist compression. (See “column”.)

**Reinforced masonry**

(1) Masonry containing reinforcement in the grouted joints or grouted cores to resist stresses. (2) Unit masonry in which reinforcement is embedded in such a manner that the component materials act together in resisting shearing and tensile forces.

**Reinforcing steel**

Steel embedded in masonry in such a manner that the two materials act together to resist forces.

**Retarding agent**

A chemical additive in mortar that slows setting or hardening, most commonly the sulphate-ion in the form of finely ground gypsum.

**Running bond**

(See “bond, running”.)

**Sash block**

(See “jamb block”.)

**Scored block**

Block with grooves that are in a visual pattern. For example, the grooves may simulate raked joints.

**Screen block**

Open-faced masonry units used for decorative purposes or to partially screen areas from the sun or outside viewers.

**Sealants**

A fluid of plastic consistency laid over a joint surface or the outside of a joint filler to exclude water.

**Shell**

The outer portion of a hollow masonry unit as placed in masonry.

**Shoring and bracing**

Props or posts used for the temporary support of members during the construction process.

**Shrinkage**

Volume change due to loss of moisture or decrease in temperature.

**Sill block**

A solid concrete masonry unit used for the sills of a wall.

**Sill**

A flat or slightly beveled stone set horizontally at the base of an opening in a wall.

**Slag, air-cooled blast-furnace**

The material resulting from solidification of molten blast-furnace slag under atmospheric conditions.

**Slag, blast-furnace**

The nonmetallic product, consisting essentially of silicates and aluminosilicates of calcium and other bases, that is developed in a molten condition simultaneously with iron in a blast furnace.

**Slag, expanded blast-furnace**

The lightweight, cellular material obtained by controlled processing of molten blast-furnace slag with water, or water and other agents.

**Slag, granulated blast-furnace slag**

The glassy, granular material formed when molten blast furnace slag is rapidly chilled, as by immersion in water.

**Slump**

The drop in the height of a wet cementitious material when its mold is removed.

**Slump block**

Concrete masonry units produced so that they slump or sag in irregular fashion before they harden.

**Slushed joints**

Head or collar joints filled after units are laid by "throwing" mortar in with the edge of a trowel.

**Solid-masonry unit**

A unit whose net cross-sectional area in every plane parallel to the bearing surface is

75 percent or more of its gross cross-sectional area measured in the same plane.

**Spall**

To flake or split away through frost action or pressure.

**Specified dimensions**

(See "dimension, specified".)

**Specified compressive strength of masonry**

Minimum compressive strength expressed as force per unit of net cross-sectional area required of the masonry used in construction by the contract documents, and upon which the project design is based.

**Split block**

A concrete masonry unit with one or more faces purposely fractured to expose the rough aggregate texture to provide architectural effects in masonry wall construction. Also called a split-faced block.

**Stack bond**

(See Bond, Stack.)

**Strike**

To finish a mortar joint with a stroke of the trowel or special tool, simultaneously removing extruding mortar and smoothing the surface of the mortar remaining in the joint.

**Struck joint**

A joint from which excess mortar has been removed by a stroke of the trowel, leaving an approximately flush joint.

**Temper**

To moisten and mix mortar to a proper consistency.

**Thermal expansion**

Expansion of a material due to an increase in temperature.

**Thermal movement**

Change of dimension of masonry resulting from change of temperatures.

**Tie**

Any unit of material that connects masonry to masonry or other materials.

**Tie, wall**

Metal connector that connects wythes of masonry walls together.

**Ties, veneer**

(See “wall tie, veneer”.)

**Tolerance**

Specified allowance of variation from a size specification.

**Tooling**

Compressing and shaping the face of a mortar joint with a special tool other than a trowel.

**Unreinforced masonry**

Masonry in which the tensile resistance of masonry is taken into consideration and the resistance of the reinforcing steel is neglected.

**Veneer, adhered**

Masonry veneer secured to and supported by the backing through adhesion.

**Veneer, anchored**

Masonry veneer secured to and supported laterally by the backing through anchors and supported vertically by the foundation or other structural elements.

**Veneer, masonry**

A masonry wythe that provides the exterior finish of a wall system and transfers out-of-plane load directly to a backing, but is not considered to add load resisting capacity to the wall system.

**Wall, bonded**

A masonry wall in which two or more wythes are bonded to act as a structural unit.

**Wall, cavity**

(1) A wall containing continuous air space with a minimum width of 1½ inches (38 mm) and a maximum width of 4-1/2 inches between wythes which are tied with metal ties. (2) A wall built of two or more wythes of masonry units separated by a continuous air space (with or without insulating materials) and in which the wythes are securely tied together with rigid corrosion resistant metal ties. (3) A wall built of masonry units arranged to provide a continuous air space within the wall (with or without insulating material) and in which the inner and outer wythes of the wall are tied together with metal tie or headers.

**Wall, composite**

A multi-wythe wall in which at least one of the wythes is dissimilar to the other wythe or wythes with respect to type of masonry unit.

**Wall, curtain**

(1) A non-loadbearing wall between columns or piers. (2) A non-loadbearing exterior wall vertically supported only at its base, or having bearing support at prescribed vertical intervals. (3) An exterior non-loadbearing wall in skeleton frame construction. Such walls may be anchored to columns, spandrel beams or floors, but not necessarily built between columns.

**Wall, exterior**

Any outside wall or vertical enclosure of a building other than a party wall.

**Wall, faced**

A wall in which the masonry facing and backing are bonded to act as a complete system under load.

**Wall, foundation**

A wall below the floor nearest grade serving as a support for a wall, pier, column or other structural part of a building and in turn, supported by a footing.

**Wall, load-bearing**

(1) A wall, carrying vertical loads greater than 200 lb/ft (2.9 kN/m), in addition to its own weight. (2) A wall that supports vertical load in addition to its own weight.

**Wall, masonry bonded hollow**

A multiwythe wall built with masonry units arranged to provide an air space between the wythes and with the wythes bonded together with masonry units.

**Wall, multi-wythe**

A wall composed of two or more wythes.

**Wall, non-loadbearing**

A wall that supports no vertical load other than its own weight.

**Wall, panel**

(1) An exterior non-loadbearing wall in skeleton frame construction, wholly supported at each story. (2) A non-loadbearing exterior masonry wall having bearing support at each story.

**Wall, partition**

An interior wall without structural function.

**Wall, prestressed**

Reinforced concrete or masonry walls in which internal stresses have been introduced to reduce potential tensile stresses in the wall resulting from imposed loads.

**Wall, reinforced**

(1) A masonry wall reinforced with steel embedded so that the two materials act together in resisting forces. (2) Walls containing reinforcement used to resist shearing and tensile stresses.

**Wall, retaining**

A wall designed to prevent the movement of soils and structures placed behind the wall.

**Wall, screen**

A masonry wall designed with decorative bricks, tile or concrete masonry units.

**Wall, shear**

Wall which, in its own plane, resists lateral load resulting from wind, blast, or earthquake.

**Wall, single wythe**

A wall of only one masonry unit in thickness.

**Wall, solid masonry**

A wall built of solid masonry units, laid contiguously, with the joint between the units filled with mortar or grout.

**Wall tie**

(1) A mechanical metal fastener which connects wythes of masonry to each other or to other materials. (2) A bonder or metal piece that connects wythes of masonry to each other or to other materials.

**Wall tie, cavity**

A rigid, corrosion-resistant metal tie that bonds two wythes of a cavity wall.

**Wall tie, veneer**

A strip or piece of metal used to tie a facing veneer to the backing.

**Wall, veneer**

A wall having a facing of masonry units or other weather resisting non-combustible materials securely attached to the backing, but not so bonded as to intentionally exert common action under load.

**Water permeance**

The ability of water to permeate through a substance such as mortar or brick.

**Water table**

A projection of lower masonry on the outside of the wall slightly above the ground. Often a damp course is placed at the level of the water table to prevent upward penetration of ground water. Generally near grade and having a beveled top and a drip cut in the projecting underside to deflect water.

**Waterproof**

Impervious to water, covered or treated with a material or materials to prevent permeation by water.

**Waterproofing**

Preventing moisture flow through masonry.

**Waterproofing materials**

Any such material or additive to mix in mortar to create watertightness.

**Watertightness**

Of such tight construction as to be impermeable to water except when under sufficient pressure to produce structural discontinuity.

**Weathering**

The action of elements in altering the color, texture, composition or form of exposed objects. The effects of nature physically and chemically upon masonry construction.

**Web**

The cross wall connecting the face shells of a hollow concrete masonry unit.

**Weep hole**

(1) An opening left (or cut) to prevent migration of water from behind a wall or within a wall. (2) Suitably formed holes or openings placed in the masonry to permit the escape of moisture from the interior of the wall. In retaining walls, a hole through the wall to permit water to flow through the wall to prevent the build up of pressure. (3) Opening in mortar joints or faces of masonry units to permit the escape of moisture, usually located immediately above flashing.

**Workability**

The ability of mortar to be easily placed and spread.

**Workmanship**

The art or skill of a workman. Craftsmanship; the quality imparted to a thing in the process of making a masonry wall, floor.

**Wythe**

Each continuous vertical section of a wall, one masonry unit in thickness.



## Appendix C Notations

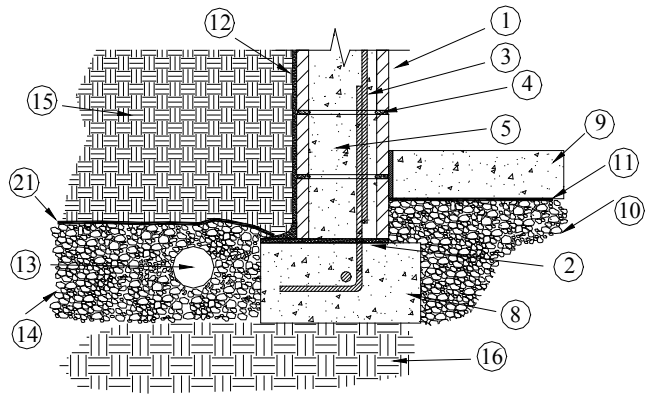
- $A_{avg}$  = average cross-sectional area of masonry section under consideration, in<sup>2</sup> (mm<sup>2</sup>).  
 $A_b$  = cross-sectional area of anchor bolt, in<sup>2</sup> (mm<sup>2</sup>).  
 $A_g$  = gross area of masonry section under consideration, in<sup>2</sup> (mm<sup>2</sup>).  
 $A_n$  = net cross-section area of masonry section under consideration, in<sup>2</sup> (mm<sup>2</sup>).  
 $A_p$  = area of tension cone of an embedded anchor bolt projected onto the surface of masonry, in<sup>2</sup> (mm<sup>2</sup>).  
 $A_s$  = cross-sectional area of reinforcement in a masonry element, in<sup>2</sup> (mm<sup>2</sup>).  
 $A_v$  = effective cross-sectional area of shear reinforcement, in<sup>2</sup> (mm<sup>2</sup>).
- $b$  = effective width of rectangular member or width of flange for T and I sections, in. (mm).  
 $b_a$  = applied axial force on an anchor bolt, lb (N).  
 $B_a$  = allowable axial force on an anchor bolt, lb (N).  
 $b_v$  = applied shear force on an anchor bolt, lb (N).  
 $B_v$  = allowable shear force on an anchor bolt, lb (N).
- $d$  = effective depth to reinforcement measured from the compression face to the center of the reinforcement, in. (mm).  
 $d_b$  = nominal diameter of anchor bolt or reinforcement, in. (mm).
- $E_m$  = modulus of elasticity of masonry, psi (MPa).  
 $E_s$  = modulus of elasticity of reinforcing steel, psi (MPa).  
 $e$  = eccentricity of applied loading, in. (mm).
- $F_b$  = allowable compressive stress due to flexure, psi (MPa).  
 $F_s$  = allowable tensile or compressive stress in reinforcement, psi (MPa).  
 $f_y$  = specified yield strength of steel, psi (MPa).  
 $f'_m$  = specified compressive strength of masonry, psi (MPa).
- $H$  = effective height of element under consideration, in. (m).
- $I_{avg}$  = average moment of inertia of masonry section under consideration, in<sup>4</sup> (mm<sup>4</sup>).  
 $I_n$  = net moment of inertia of masonry section under consideration, in<sup>4</sup> (mm<sup>4</sup>).
- $K_a$  = coefficient of active earth pressure.  
 $K_p$  = coefficient of passive earth pressure.  
 $K_o$  = coefficient of at-rest earth pressure.
- $l_b$  = effective embedment length of anchor bolt, in. (mm).  
 $l_{be}$  = anchor bolt edge distance measure from the surface of the bolt to the nearest free edge of masonry in. (mm).
- $M_{max}$  = maximum bending moment due to applied loading, ft-lb (N-m).  
 $M_R$  = resisting bending moment, ft-lb (N-m).

- mil = one-thousandth of an inch (1/1000 in.)
- $P$  = total lateral load applied to wall from soil, lb/ft (N/m).
- $P_{EF}$  = equivalent soil fluid pressure, lb/ft<sup>2</sup>/ft (N/m<sup>2</sup>/m).
- $r_{avg}$  = average radius of gyration of masonry section under consideration, in. (mm).
- $r_n$  = net radius of gyration of masonry section under consideration, in. (mm).
- $R_B$  = reaction at bottom of wall resisting applied lateral loads, lb/ft (N/m).
- $R_T$  = reaction at top of wall resisting applied lateral loads, lb/ft (N/m).
- $s$  = spacing of reinforcement, center to center distance, in. (mm).
- $S_{avg}$  = average section modulus of masonry section under consideration, in<sup>3</sup> (mm<sup>3</sup>).
- $S_n$  = net section modulus of masonry section under consideration, in<sup>3</sup> (mm<sup>3</sup>).
- $V_{max}$  = maximum shear force due to applied loading, lb (N).
- $V_R$  = resisting shear force, lb (N).
- $w_B$  = load at base of wall from soil, lb/ft (N/m).
- $X$  = distance measured relative to the top of the wall, ft (m).
- $X_{Mmax}$  = location of maximum bending moment measured relative to the top of the wall, ft (m).
- $X_{Vmax}$  = location of maximum shear force measured relative to the top of the wall, ft (m).
- $X_{\delta max}$  = location of maximum deflection measured relative to the top of the wall, ft (m).
- $\alpha$  = angle of the slope of the backfill measured relative to the horizontal, degrees.
- $($  = ratio of height of backfill to total height of wall.
- $\delta_{max}$  = maximum deflection of wall due to applied loads, in. (mm).
- $\epsilon$  = strain, in./in. (mm/mm).
- $\Delta$  = soil density, lb/ft<sup>3</sup> (kg/m<sup>3</sup>).
- $N$  = internal friction angle of soil, degrees.

## References

1. National Concrete Masonry Association, Building Radon Resistant Foundations, TR 104, Herndon, VA, 20171, 1989.
2. American Concrete Institute International, 38800 Country Club Drive, Farmington Hills, MI, 48331.
3. U.S. Environmental Protection Agency, 1200 Pennsylvania Avenue NW, Washington, DC, 20460.
4. Portland Cement Association, 5420 Old Orchard Road, Skokie, IL, 60077.
5. American Society for Testing and Materials, 2001:
  - A. Standard Specification for Loadbearing Concrete Masonry Units, ASTM C 90-01.
  - B. Standard Specification for Mortar for Unit Masonry, ASTM C 270-00.
  - C. Standard Specification for Grout for Masonry, ASTM C 476-01.
  - D. Standard Test Method for Sampling and Testing Grout, ASTM C1019-00b.
  - E. Standard Test Methods for Fire Tests of Building Construction and Materials, ASTM E 119-00a.
  - F. Standard Specification for Modifiers for Masonry Mortars, ASTM C 1384-01.
6. International Code Council, International Building Code, Falls Church, VA, 22041, 2000.
7. Specification for Masonry Structures, ACI 530.1-99/ASCE 6-99/TMS 602-99, Reported by the Masonry Standards Joint Committee, 1999.
8. Building Code Requirements for Masonry Structures, ACI 530-99/ASCE 5-99/TMS 402-99, Reported by the Masonry Standards Joint Committee, 1999.
9. International Code Council, International Residential Code, Falls Church, VA, 22041, 2000.
10. U.S. Department of the Interior, U.S. Geological Survey, Reston, VA, 20191.
11. Standard Tolerances for Concrete Construction and Materials, American Concrete Institute, Farmington Hills, MI, 48331, 1990.
12. National Concrete Masonry Association:
  - A. Control Joints for Concrete Masonry Walls, TEK 10-2A, 1998.
  - B. Blast and Bullet Resistant Concrete Masonry Buildings, TEK 14-21, 1998.
  - C. Allowable Stress Design of Concrete Masonry Pilasters, TEK 17-4B, 2000.
  - D. Anchor Bolts for Concrete Masonry, TEK 12-3, 1996.
  - E. Sound Transmission Class Ratings for Concrete Masonry Walls, TEK 13-1A, 2000.
  - F. R-Values for Single Wythe Concrete Masonry Walls, TEK 6-2A, 1996.

- G. The Structural Role of Joint Reinforcement in Concrete Masonry, TEK 12-2B, 2000.
13. Minimum Design Loads for Buildings and Other Structures, ASCE 7-98, American Society of Civil Engineers, Reston, VA, 20191, 1998.
  14. Sowers, G., Introductory Soil Mechanics and Foundation: Geotechnical Engineering, MacMillan Publishing Company, NY, 1979.
  15. National Concrete Masonry Association, Design Tables for Concrete Masonry and Precast Concrete Lintels, TR 91A, Herndon, VA, 20171, 1996.
  16. Masonry Structures – Behavior and Design, Drysdale, R.C., Hamid, A.A., Baker, L.R., The Masonry Society, Boulder, CO, 1999.
  17. International Code Council, International Energy Conservation Code, Falls Church, VA, 22041, 2000.
  18. Standard Practice for Bracing Masonry Walls Under Construction, Council for Masonry Wall Bracing, 2001.



Published by:  
National Concrete Masonry Association  
13750 Sunrise Valley Drive  
Herndon, VA 20171  
[www.ncma.org](http://www.ncma.org)

NCMA Publication Number TR 68B  
ISBN 1-881384-14-4

NATIONAL  
**NCMA**  
CONCRETE MASONRY  
ASSOCIATION