



ACB Design Manual

ACB-MAN-001-20



MASONRY &
HARDSCAPES

DESIGN MANUAL FOR ARTICULATING CONCRETE BLOCK (ACB) REVETMENT SYSTEMS

ACKNOWLEDGEMENT

The National Concrete Masonry Association *Design Manual for Articulating Concrete Block (ACB) Revetment Systems* is from the Harris County Flood Control District (Harris County, Texas) manual addressing articulating concrete block design. The National Concrete Masonry Association (NCMA) acknowledges with appreciation for their significant contributions to this manual:

The Harris County Flood Control District
Mr. Paul Clopper, P.E. of Ayres Associates
Dr. Christopher Thornton, P.E. of Colorado State University

The NCMA Articulated Concrete Block Subcommittee
David Pitre, Chairman

Doug Buch
R. Lance Carter
Ken MacAllister
Victoria McCrie
Dale Puskas
Mac Schmidt
Wayne Villaluna
Kevin Vogler

NATIONAL
NCMA
CONCRETE MASONRY
ASSOCIATION

13750 Sunrise Valley Drive
Herndon, Virginia, 20171
(703) 713-1900, FAX (703) 713-1910 www.ncma.org

August, 2010

DISCLAIMER

THIS MANUAL WAS PREPARED AND IS BEING DISTRIBUTED MERELY AS AN OVERVIEW WITH REGARD TO SOME ISSUES THAT COULD RELATE TO DESIGNING ARTICULATING BLOCK SYSTEMS. NCMA DOES NOT REPRESENT, WARRANT, OR GUARANTEE THAT THE MANUAL IS FREE OF ERRORS OR OMISSIONS. THIS MANUAL IS BEING RECEIVED AND USED AT THE USER'S OWN RISK "AS IS," "AS IT STANDS," AND "WITH ALL FAULTS." NCMA EXPRESSLY DISCLAIMS ALL LIABILITY FOR ANY CLAIMS OR DAMAGE, DIRECT OR CONSEQUENTIAL, FROM MATERIAL CONTAINED WITHIN THE MANUAL, AND FURTHER EXPRESSLY DISCLAIMS ALL WARRANTIES, EXPRESS OR IMPLIED, WHICH RELATE OR IN ANY WAY COULD RELATE TO THE MANUAL. THE USER SHOULD OBTAIN INDEPENDENT, COMPETENT PROFESSIONAL ADVICE TO DETERMINE WHETHER THE MATERIAL CONTAINED WITHIN THE MANUAL IS CURRENT, APPLICABLE, AND CORRECT AT THE TIME OF ITS USAGE.

NCMA SHALL NOT BE RESPONSIBLE FOR ERRORS OR OMISSIONS INCLUDED WITHIN OR IN ANY WAY ASSOCIATED WITH THE MANUAL, AND THEY SHALL BE HELD HARMLESS FOR SAME.

LIMITED REPRODUCTION OR MODIFICATION

It is expressly understood and agreed by accepting and using the manual, that neither the manual nor any part thereof shall be copied, otherwise reproduced, or modified without the prior express written permission of NCMA.

COPYRIGHT

Copyright 2010 © National Concrete Masonry Association
ISBN 1-881384-20-9
NCMA Publication Number TR220A

ABOUT NCMA

The National Concrete Masonry Association (NCMA) is a not-for-profit organization whose mission is to support and advance the common interests of its members in the manufacture, marketing, research, and application of concrete masonry and hardscape products. The Association is an industry leader in providing technical assistance, education, marketing, research and development, and product and system innovation to its members and to the industry.

NCMA ENGINEERING STAFF

Jason J. Thompson, Director of Engineering
Dennis W. Graber, Director of Technical Publications
Gabriela Mariscal, Geotechnical Engineer
Nicholas R. Lang, Manager, Research & Development Laboratory

TABLE OF CONTENTS

1.0 INTRODUCTION	1
1.1 Background	1
2.0 OPEN CHANNEL HYDRAULICS FOR ACB DESIGN	5
3.0 GEOMORPHIC CONSIDERATIONS FOR ACB DESIGN	11
4.0 DESIGNING ACB SYSTEMS FOR HYDRAULIC STABILITY	13
4.1 Performance Testing of ACB Systems	13
4.2 Extrapolation of Test Data	15
4.3 Factor of Safety Design Equations	17
4.4 Factor-of-Safety Methodology for ACBs	21
4.5 Extent of Revetment Coverage	23
4.6 Cabled Versus Non-Cabled ACB Systems	23
4.7 Drainage Layers	24
4.8 ACB Design Procedure and Example	24
5.0 GEOTEXTILE AND GRANULAR FILTER DESIGN	33
5.1 Filter Functions	33
5.2 Base Soil Properties	37
5.3 Geotextile Filter Properties	39
5.4 Granular Filter Properties	40
5.5 Filter Design Procedure and Example	40
6.0 MANUFACTURE REQUIREMENTS FOR ACB SYSTEMS	53
7.0 INSTALLATION GUIDELINES	55
7.1 Subgrade Preparation	55
7.2 Placement of Geotextile	56
7.3 Placement of ACB System	57
7.4 Finishing	61
7.5 Inspection	61
8.0 Worksheets	63
9.0 Annotated Bibliography	71
Appendix A: Design Equations on SI Units	81
Metric Conversion Table	87
Notations and Abbreviations	89

LIST OF FIGURES

Figure 1.1. Examples of proprietary ACB systems shown in plan view	1
Figure 2.1. (A) Plan view of a river meander bend with region of increased shear stress indicated (B) Cross section A-A' illustrating superelevation at outer bank of the bend	6
Figure 2.2. Two-dimensional model results with velocity vectors at a waterway constricted by bridge approach embankments.....	6
Figure 2.3. Horseshoe vortex flow pattern observed at bridge piers.....	7
Figure 2.4. Schematic of a block protruding above ACB matrix resulting in added drag and lift forces overturning the block	8
Figure 2.5. Relationship between drag force, velocity and protrusion height.....	9
Figure 4.1. Moment Balance on an ACB at Incipient Failure	14
Figure 4.2. Typical laboratory flume configuration and photographs of the full-scale testing facility.....	15-16
Figure 4.3. Three-dimensional view of a block on a channel side slope with factor of safety variables defined.....	18
Figure 4.4. Figure of a block showing moment arms P_1 , P_2 , P_3 , and P_4	19
Figure 4.5. Comparison between the potential intra-block friction between 4.5 in. (114 mm) and 9.0 in. (229 mm) ACB units.....	22
Figure 4.6. Definition sketch of example problem setting and ACB installation	26
Figure 4.7. Velocity Distribution at Critical Cross-Section from HEC-RAS Model.....	27
Figure 5.1. Channel cross sections showing filter and bedding orientation	33
Figure 5.2. Examples of soil and filter subgrades	34
Figure 5.3. Time series of channel and groundwater level changes resulting from a storm event	36
Figure 5.4. Geotextile selection based on soil retention (Ref. 31).....	43
Figure 5.5. Granular filter design chart according to Cistin and Ziems (Ref. 31).....	45
Figure 7.1. Granular filter detail showing granular filter encapsulation	57
Figure 7.2. ACB mats being placed with a crane and spreader bar.....	58

LIST OF FIGURES (continued)

Figure 7.3. Close-up of spreader bar and ACB mat.....	58
Figure 7.4. Conceptual detail of minimum radius-of-curvature for bed and bank protection.....	59
Figure 7.5. Bed and bank protection with minimum radius-of-curvature at grade changes and top-of-slope termination points	59
Figure 7.6. Conceptual detail of minimum radius-of-curvature for bank protection.....	60
Figure 7.7. Conceptual detail of toe termination for spillways or embankment overtopping flow	60
Figure 7.8. Embankment dam overtopping protection with radius-of-curvature at top-of-slope termination.....	61

LIST OF TABLES

Table 4.1 Design Equations for ACB Systems.....	20
Table 4.2 HEC-RAS Model Output at Critical Design Section	25
Table 5.1 Porosity and Permeability for Alluvial Soils	38
Table 5.2 General Soil Sample Information and Classification	41
Table 5.3 Results from Sieve Analysis of Base Soil.....	41
Table 5.4 Pit Run Sand Gradation for Granular Filter	45
Table 5.5 Geotextile Strength Requirements (AASHTO M-288).....	47

1.0 INTRODUCTION

1.1 Background

This design manual provides guidelines and procedures for the design and installation of articulating concrete block revetment systems. Articulating concrete block (ACB) systems are used to provide erosion protection to underlying soil from the hydraulic forces of moving water. An ACB system is comprised of a matrix of individual concrete blocks placed together to form an erosion-resistant revetment with a geotextile underlay for subsoil retention. The term "articulating" implies the ability of the matrix to conform to minor changes in the subgrade while remaining interlocked with or without the use of cables, geotextiles or geogrids. Several varieties of ACB systems are available: interlocking, cable-tied and non-cable-tied matrices, and open cell and closed cell varieties. Open cell units contain open voids within individual units that facilitate the placement of aggregate and/or vegetated soil. Closed cell units are solid, concrete elements that are capable of allowing vegetation growth between adjacent units. Figure 1.1 shows a variety of ACB units in plan view.

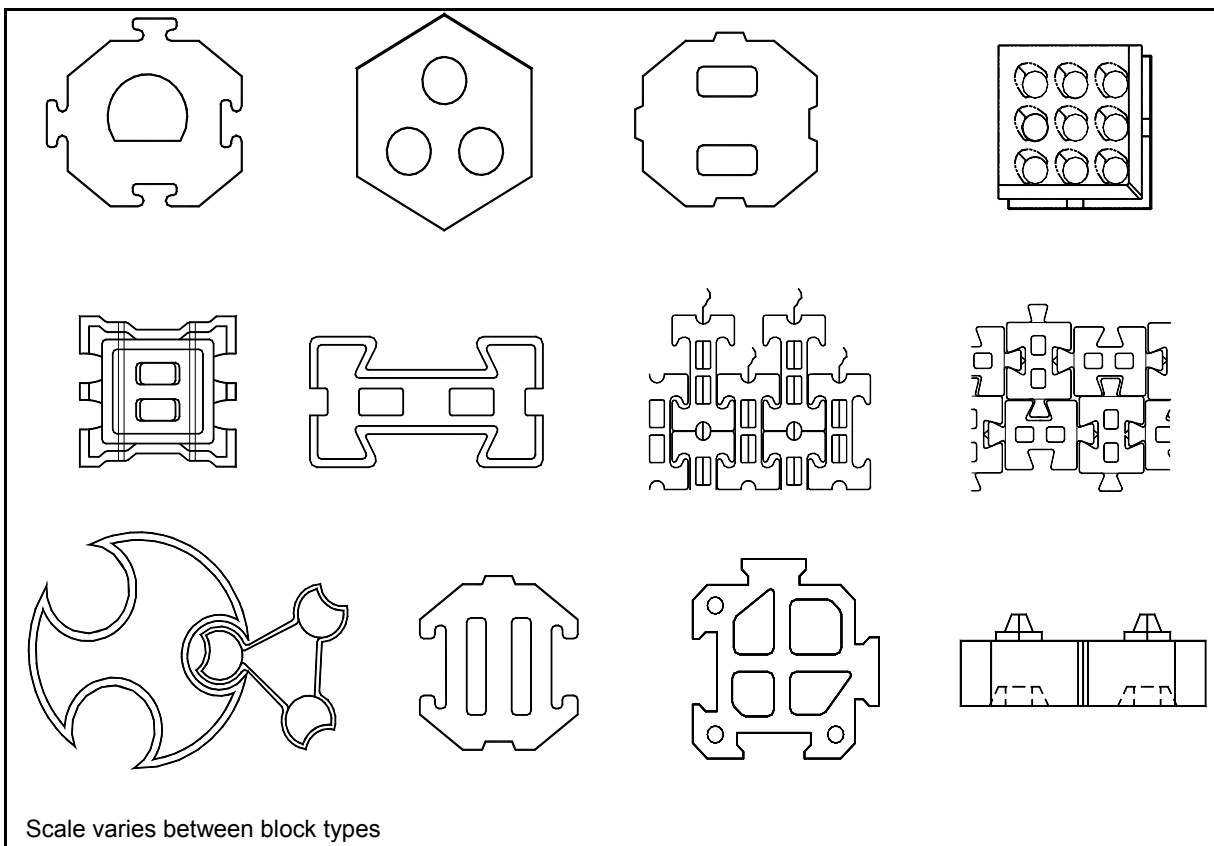

Figure 1.1—Examples of proprietary ACB systems shown in plan view. This is not all inclusive of available configurations. No endorsement or recommendation is intended.

The ACB system includes a filter component that allows infiltration and exfiltration to occur while retaining the soil subgrade. The filter layer requires a geotextile and may include a granular transition layer. In some cases a highly permeable drainage layer, either granular or synthetic, may be included in the system to provide sub-block pressure relief, particularly in turbulent flows or wave-attack environments.

Articulating concrete blocks can be used in a broad range of erosion control applications with success. Since ACB systems have a very high armoring potential, application is not limited to subcritical flow or locations of low turbulence. ACB systems have been used with excellent success at installations generating high velocities such as culvert outlets, spillways, and grade control structures. In many laboratory studies, ACB systems have maintained structural stability in flow velocities conditions exceeding 20 ft/s (6 m/s), where failure was defined as any loss of contact between the block and the subgrade. In many geographic regions, ACB systems offer a less expensive and more aesthetically appealing alternative to other treatments such as riprap, structural concrete, rigid grout filled mats (pump mats), and soil cement. The design and construction of these alternative systems is not addressed in this manual.

The permeable characteristic of ACBs allows their use also to preserve natural drainage and treatment systems by regional authorities, drainage districts, counties, cities and towns. ACBs installed on filter media are pervious surfaces that reduce the water runoff and flooding risks, improve water quality, reduce pollutants, recharge aquifers and prevent erosion. These environmental characteristics permit the use of ACBs on sustainable developments to preserve or improve existing sites and can be applied for credits in some green building rating systems.

ACB systems are well suited to channel lining applications, in particular for lateral stream stability. The articulating characteristic allows the systems to be placed effectively at bends and regions of vertical change, such as sloping grade control structures. Many ACB systems are manufactured with voids or open cells to accommodate vegetation.

ACB systems are intended for erosion control, not slope stabilization. As such, these systems should not be placed on slopes that are geotechnically unstable or exhibit bedslope angles steeper than that used during hydraulic performance testing. Geotechnical engineering and slope stabilization references should be sought for solutions to these topics.

This manual is intended to provide a standardized basis for the analysis, design, and installation of ACB systems for erosion control applications in open channels or similar hydraulic flow conditions. Design provisions in this manual are applicable, but not limited, to the following:

- Areas of channelized flow – flumes, channels, waterways
- Spillways, dam overtopping, and levees
- Stormwater control and infiltration

Topics addressed in this manual include:

- Chapter 2. Open Channel Hydraulics for ACB Design—provides background of open channel hydraulics related to ACB design;
- Chapter 3. Geomorphic Considerations for ACB Design—provides insight and references for stability assessment of a site prior to ACB application;
- Chapter 4. Designing ACB Systems for Hydraulic Stability—provides discussion of laboratory testing, design criteria and equations, special topics, and an ACB design procedure;

- Chapter 5. Geotextile and Granular Filter Design—provides information regarding the significance of the filter layer, base soil and filter properties, and a filter design procedure;
- Chapter 6. Manufacture Requirements for ACB Systems—provides information regarding the manufacture and recommended material properties for ACB units;
- Chapter 7. Installation Guidelines—provides recommendations and requirements for ACB installation procedures for effective erosion control performance;
- Chapter 8. Worksheets,—provides design worksheets to assist with calculations, and example detail sheet(s);
- Chapter 9. Annotated Bibliography—provides a list of cited references and additional references for subjects beyond the scope of this manual, with a short narrative describing relevant aspects of each document; and
- Appendix A. Design Equations on SI Units,—provides the design equations presented in this document in SI units.

2.0 OPEN CHANNEL HYDRAULICS FOR ACB DESIGN

Effective design of ACB revetment systems depends upon proper characterization of the hydraulic conditions expected during the design event. The vast majority of revetment failures, whether riprap or manufactured systems, occurred in cases where the designer did not adequately quantify the hydraulics of flow.

The design procedure presented in this ACB design manual is based on an approach that considers the hydraulic forces imposed on a single block at incipient failure of the system. In formulating the equations for practical use, a ratio of design shear stress to "critical" shear stress is used. Although shear stress and flow velocity are important variables in ACB system design, the referenced design procedure incorporates flow velocity as an input variable when considering block protrusion/placement tolerance and its effect on stability. Flow velocity is a critical variable in the laboratory and field performance of the system. Therefore, it is important that the peak velocity determined during full-scale flume testing be reported and that the design velocity not exceed the laboratory test velocity associated with the reported "critical" shear stress. The average cross-section shear stress can be calculated for design using the following simple equation:

$$\tau_0 = \gamma R S_f \quad (\text{Eqn. 2.1})$$

where:

τ_0	=	Cross-section-averaged shear stress, lb/ft ²
γ	=	Unit weight of water, 62.4 lb/ft ³
R	=	Hydraulic radius, ft
S_f	=	Slope of the energy grade line, ft/ft

Historically, full-scale testing results published by the Federal Highway Administration (FHWA), "Minimizing Embankment Damage During Overtopping Flow" (ref. 23) and "Hydraulic Stability of Articulated Concrete Block Revetment Systems During Overtopping Flow" (ref. 21) were originally used to provide performance data on ACB systems. Two relatively new ASTM standards have been developed based on the FHWA method: "D7276 Standard Guide for Analysis and Interpretation of Test Data for Articulating Concrete Block (ACB) Revetment Systems in Open Channel Flow" (ref. 18) and "D7277 Standard Test Method for Performance Testing of Articulating Concrete Block (ACB) Revetment Systems for Hydraulic Stability in Open Channel Flow" (ref. 19), that eventually will replace the FHWA test method. These standards provide currently recommended guidance for the performance testing of ACB systems. The data developed from the full-scale tests are then provided to the designer in the form of critical shear stress (also known as maximum allowable shear stress). Results provided to the designer should also include the maximum test velocity and bed slope geometry tested to derive critical shear stress data. A background discussion of laboratory flume testing of ACB systems is provided later in this manual (Section 4.1). A bed slope of 2H:1V is used for performance testing. The designer should verify the bed slope angle used in the performance test to determine the block shear stress value (τ_c).

For some applications, cross-section-averaged shear stress is not suitable for design. Such cases include bends, confluences, constrictions, and flow obstructions. An example of how shear stress can vary in a complex flow field is illustrated in the river meander bend of Figure 2.1. The superelevation of the water surface against the outside bank of the bend produces a locally steep downstream water surface slope and, as a result, a region of increased shear

stress. A similar phenomenon can occur at bridge crossings where approach embankments encroach on a floodplain. A locally steep water surface is developed near the bridge abutment between the water backed up behind the embankment and the water moving through the bridge opening at a much higher velocity.

For complex hydraulic systems, more sophisticated modeling is generally an appropriate solution. For example, a two-dimensional model would be the appropriate method for determining shear stress through a bridge where the approach embankment(s) constrict a wide floodplain. A two-dimensional model showing velocity vectors through a constricted waterway is shown in Figure 2.2. More sophisticated modeling tools are discussed in the annotated bibliography provided at the end of this manual along with their availability and ordering information.

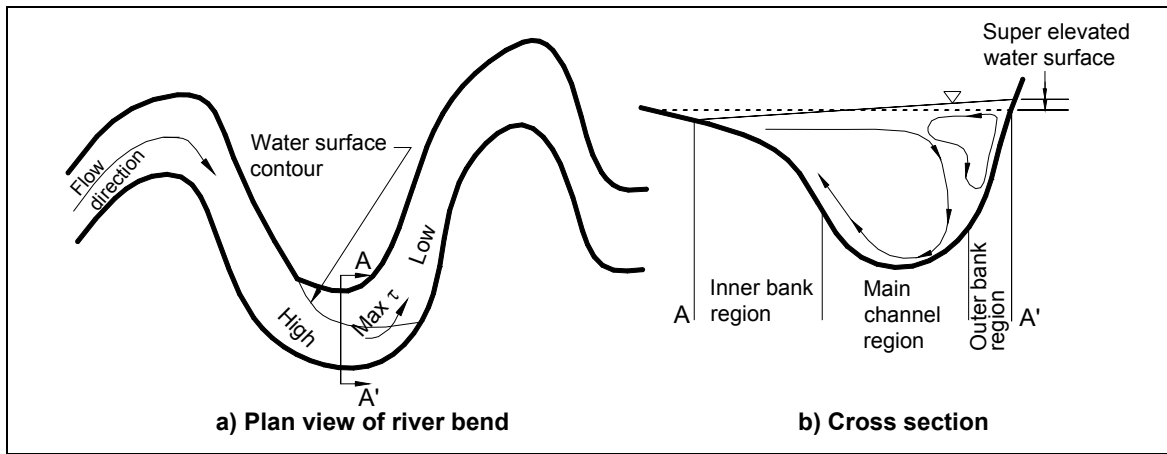

Figure 2.1—(A) Plan view of a river meander bend with region of increased shear stress indicated (B) Cross section A-A' illustrating super elevation at outer bank of the bend.

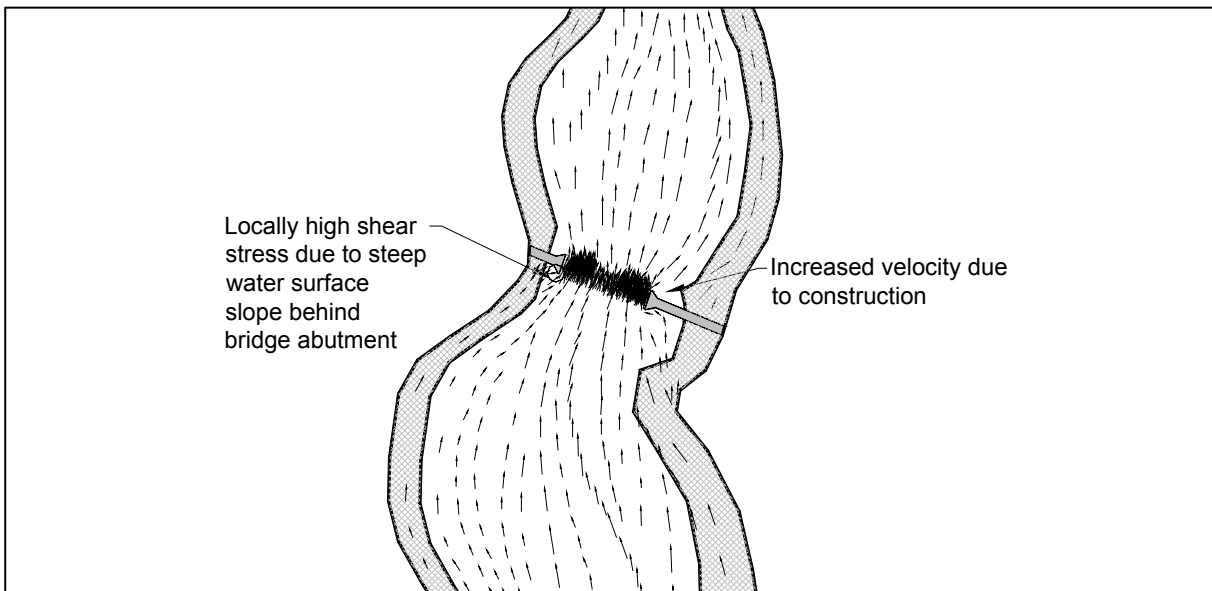

Figure 2.2—Two-dimensional model results with velocity vectors at a waterway constricted by bridge approach embankments.

If a simplified modeling approach, such as the Manning equation or the HEC-2 model, is used to model a complex hydraulic system, then conservatism should be incorporated into the design shear stress and factor of safety (discussed later in Chapter 4). In the case of flow around a bend, velocity can range between 0.9 and 1.7 times the cross-section-averaged velocity (ref. 31). Because shear stress is proportional to the square of velocity, the range of multipliers that is suggested for shear stress is 0.8 to 2.9. Some example shear stress multipliers are provided as follows:

- 0.8 for a location near the bank of a straight reach
- 1.4 for a location in the main current of flow of a meander bend
- 2.9 for a location in the main current of flow of an extreme bend

To date, there is limited information available for quantifying how velocity and shear stress increase locally at obstructions to a flow field, such as bridge piers or pipelines. Flow around local obstructions is very turbulent and generally results in some vortex flow pattern, both contributing to very erosive flows. A schematic of the horseshoe shaped vortex often observed at flow around bridge piers is provided in Figure 2.3. The rearranged Isbash riprap equation for piers from “Bridge Scour and Stream Instability Countermeasures, Experience Selection, and Design Guidance, 3rd Edition” (ref. 31) uses a velocity multiplier of 1.5 for round piers and 1.7 for rectangular piers. These values correspond to shear stress multipliers of 2.3 and 2.9 for round and square piers, respectively. It is suggested that these values be used along with an increased design factor of safety for bridge piers.

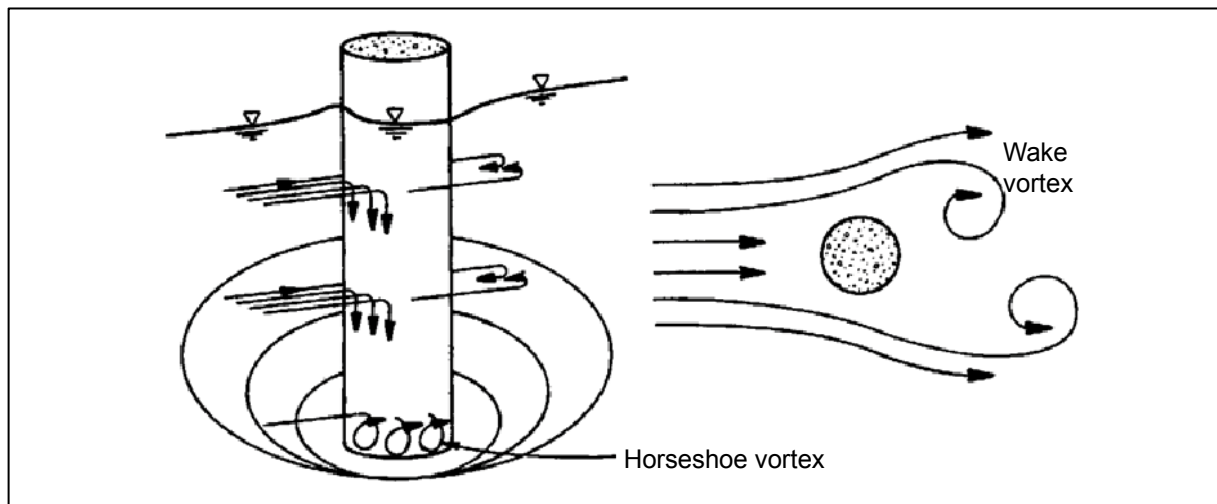

Figure 2.3—Horseshoe vortex flow pattern observed at bridge piers.

Flow velocity becomes a significant hydraulic variable when considering the potential for destabilizing forces on individual blocks, which can result from blocks protruding above the surrounding ACB matrix due to local subgrade irregularities or imprecise placement. The problem is presented in the schematic of Figure 2.4. The added drag on the block is a function of the velocity of the water squared according to the following relationship:

$$F'_D = 1/2 \cdot C_D (\Delta Z) b_p V^2 \quad (\text{Eqn. 2.2})$$

where:

F'_D	=	Drag force due to block protrusion, lb
C_D	=	Drag coefficient ($C_D \approx 1.0$)
ΔZ	=	Height of protrusion, ft
b	=	Block width perpendicular to flow, ft
ρ	=	Density of water, 1.94 slugs/ft ³
V	=	Velocity, ft/s

Note that V must be less than or equal to the maximum tested velocity (V_{max}) used in determining the critical shear stress (τ_c) for the block system. Figures 2.5a and 2.5b illustrate the effect of drag force for various velocities and protrusion heights.

The added lift force (F'_L) due to the block protruding above the ACB matrix is conservatively assumed equal to the drag force (F'_D). With the added drag force imposed on the block proportional to velocity squared, proper subgrade preparations and installation quality control are very important, especially in regions of high flow velocity, such as supercritical reaches and overtopping spillways. In the design procedure that follows, allowable height of block protrusion is specified by the designer and should be used by inspectors as a criterion for acceptance or rejection of the installation.

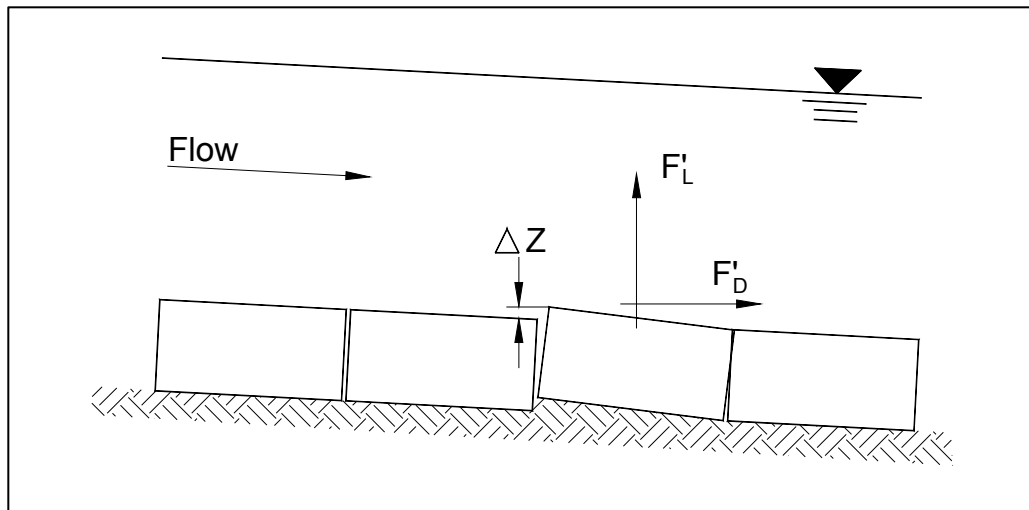

Figure 2.4—Schematic of a block protruding above ACB matrix resulting in added drag and lift forces overturning the block.

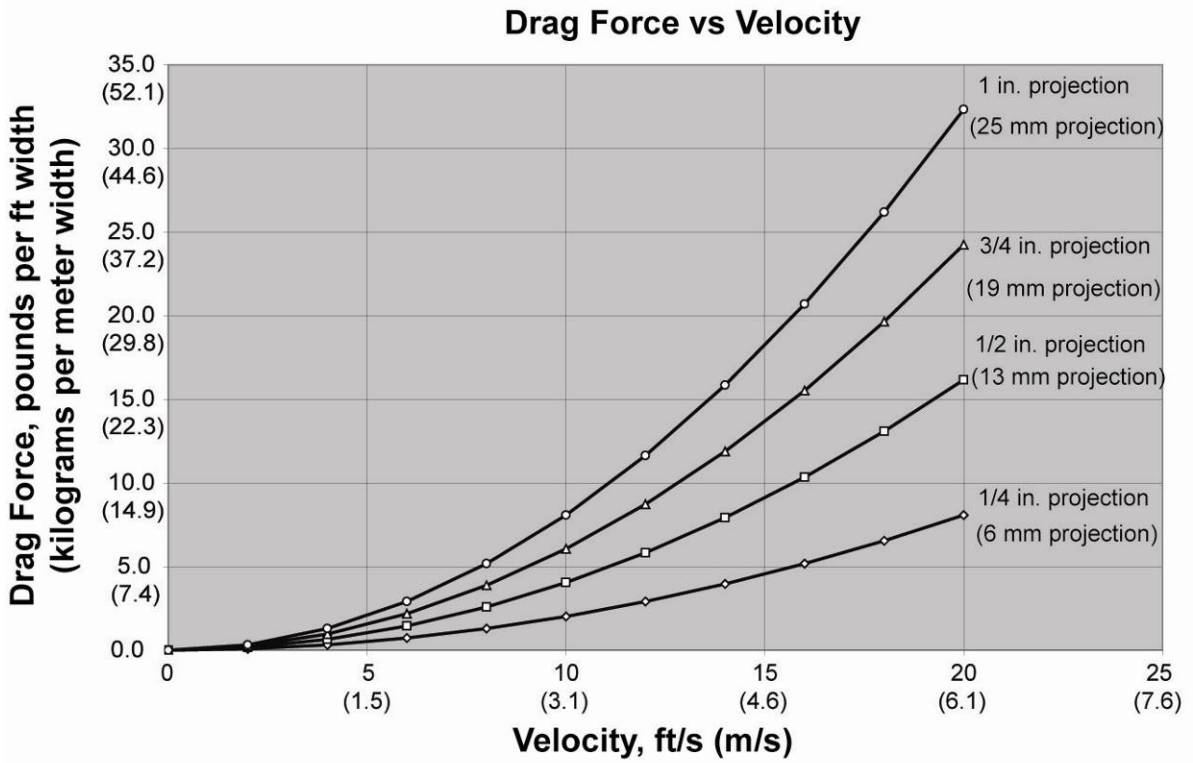

Figure 2.5—Relationship between drag force, velocity and protrusion height – Inch-Pound units (SI units).

3.0 GEOMORPHIC CONSIDERATIONS FOR ACB DESIGN

Ascertaining whether or not a stream is stable requires a functional definition of stability. In the context of ACB design, stability implies that the geomorphic state of the stream, with the ACB system in place, is such that adverse conditions to the revetment do not develop over time.

Hydraulic Engineering Circular No. 20 (HEC-20), "Stream Stability at Highway Structures" (ref. 30) provides a stability characterization system that classifies several stream properties as being unstable or stable. The system is qualitative in nature, but provides a quick method for ascertaining stability of a stream using very little data, which includes, annual hydrograph characteristics, soil properties, aerial photography, and land topography. Thirteen stream properties are used in the method, which can be categorized into temporal flow characteristics, channel boundary characteristics, topographic relief, plan geometry, and cross-section geometry.

Many natural streams migrate laterally without impacting the stream as a system (i.e., effects of migration do not propagate upstream and downstream). However, lateral migration becomes a concern when the security of nearby infrastructure from erosion is jeopardized. In such cases, ACB systems can be used as a countermeasure or as a component of a countermeasure to arrest lateral migration. The designer is referred to HEC-23, "Bridge Scour and Stream Instability Countermeasures" (ref. 31) for lateral instability countermeasure options.

In many applications, an ACB system is used for embankment streambank lining while a "soft" channel bed is maintained for environmental, habitat, or economic reasons. The vertical stability of the project site, in terms of aggradation or degradation, should be quantified to determine the sufficient toe-down depth for the revetment. Long-term bed elevation changes are usually the result of change(s) to the watershed system, such as: urbanization, deforestation, channelization, meander cutoff, and changes to downstream base level control elevation. Since vertical instability is typically indicative of system-wide response, local use of articulating concrete blocks should not be used as the sole countermeasure to arrest degradation.

Prediction of long-term bed elevation changes is a multi-disciplinary problem that must be solved using a system analysis approach. Analysis of the problem requires the consideration of all influences to the system: runoff from the watershed (hydrology), sediment delivery to the channel reach (sedimentology), sediment transport capacity of the reach (hydraulics), and the response of the channel to these factors (geomorphology). HEC-20, "Stream Stability at Highway Structures" (ref. 30) offers a three level system approach to fully characterize stream stability:

- Level 1: Application of simple geomorphic concepts and other qualitative analyses.
- Level 2: Application of basic hydrologic, hydraulic, and sediment transport engineering concepts.
- Level 3: Application of mathematical or physical modeling studies.

Not all three levels of analysis must be completed. Instead, it is suggested that each level of analysis be carried out until adequate characterization of stream stability is achieved. Given adequate characterization of stream stability, the designer can then utilize HEC-23, "Bridge

Scour and Stream Instability Countermeasures" (ref. 31) for countermeasure design, if needed.

4.0 DESIGNING ACB SYSTEMS FOR HYDRAULIC STABILITY

This chapter defines a procedure for designing ACB systems based on hydraulic stability concepts. A linkage between performance testing in laboratory flumes and real-world field applications is described and a method that uses results from full-scale performance tests is presented.

In the design of ACB systems, a factor of safety is calculated for the proposed product and then assessed against a pre-selected target value. This chapter presents equations for calculating a factor of safety for a specific ACB system, a rational approach to pre-selecting a target factor of safety, and a design procedure that compares the calculated and pre-selected values. Special topics related to ACB design are also addressed in this chapter.

4.1 Performance Testing of ACB Systems

Starting in 1983, the Federal Highway Administration (FHWA) led a group of federal agencies in a multi-year research program to evaluate the performance of different erosion control systems for embankment overtopping flow. “Minimizing Embankment Damage During Overtopping Flow” (ref. 23) summarizes the results from the investigation. The erosion control systems in that 1988 report included three proprietary articulating concrete block systems. Test results indicated that ACB systems showed promise as an erosion control countermeasure under severe hydraulic loading; however, the performance of tested systems varied significantly. The scope of the 1988 study does not provide a thorough understanding of the failure mechanisms associated with ACB systems and does not provide reasons for the broad range in system performance. “Hydraulic Stability of Articulated Concrete Block Revetment Systems During Overtopping Flow” (ref. 21) provides a follow up report that more thoroughly addresses these issues.

Concurrent with FHWA testing, researchers in Great Britain were evaluating the performance of similar erosion control systems. Both the FHWA and British researchers agreed that a suitable definition of "failure" for ACB systems is the local loss of intimate contact between the ACB and the subgrade that it protects. Ref. 21 outlines four causative mechanisms that will result in this definition of failure:

1. Loss of embankment soil beneath the system by gradual erosion along the slope beneath the system or washout through the system at joints and open cells;
2. Deformation of the underlying embankment through liquefaction and shallow slip of the embankment soil caused by the ingress of water beneath the system;
3. Loss of a block or group of blocks (uncabled systems) which directly exposes the subgrade to the flow;
4. Local uplift of a block or group of blocks due to hydraulic loading.

Refinements to the original FHWA test procedures “Minimizing Embankment Damage During Overtopping Flow” (ref. 23) have resulted in new test protocols. ASTM D7277 “Standard Test Method for Performance Testing of Articulating Concrete Block (ACB) Revetment Systems for Hydraulic Stability in Open Channel Flow” (ref 19) is based on the mentioned procedure and was recently introduced is currently recommended for testing ACB systems.

The loss of intimate contact is most often the result of overturning of a block or group of blocks, in which incipient failure occurs when the overturning moments equal the restraining

moments about the downstream contact point of an individual block. The hydraulic stability of a block is thus a function of its restraining moments (block weight and inter-block restraint) versus the applied overturning moments from hydrodynamic drag and lift. Inter-block restraint is the force resulting from block-to-block contact that resists overturning. The process of incipient failure is illustrated in the moment balance of Figure 4.1.

Summing moments acting on the block at incipient failure produces an equation defining hydraulic stability. The following equation, which conservatively ignores inter-block restraint is recommended; with the restraining moments on the left side of the equation and the overturning moments on the right side:

$$\ell_2 W_{S2} = \ell_1 W_{S1} + \ell_3 (F_D + F'_D) + \ell_4 (F_L + F'_L) \quad (\text{Eqn. 4.1})$$

See Figure 4.1 for nomenclature.

Figure 4.1 illustrates that the ability of any ACB system to provide a stable erosion resistant boundary under a given set of hydraulic conditions is a function of its weight, inter-block restraint, geometry, and quality of installation. In addition, the ability of a system to provide a degree of flexibility through block-to-block articulation is an important factor in maintaining intimate contact between the system and the subgrade that it protects. Since these characteristics can vary greatly between ACB systems, laboratory flume testing of a system is necessary to quantify the performance of a particular system. Using test results, the manufacturer can provide performance data in the form of "critical" shear stress, maximum test velocity, and test bed slope geometry to the designer of the ACB system. The term critical implies the condition at the brink of failure (loss of intimate contact) of a single block.

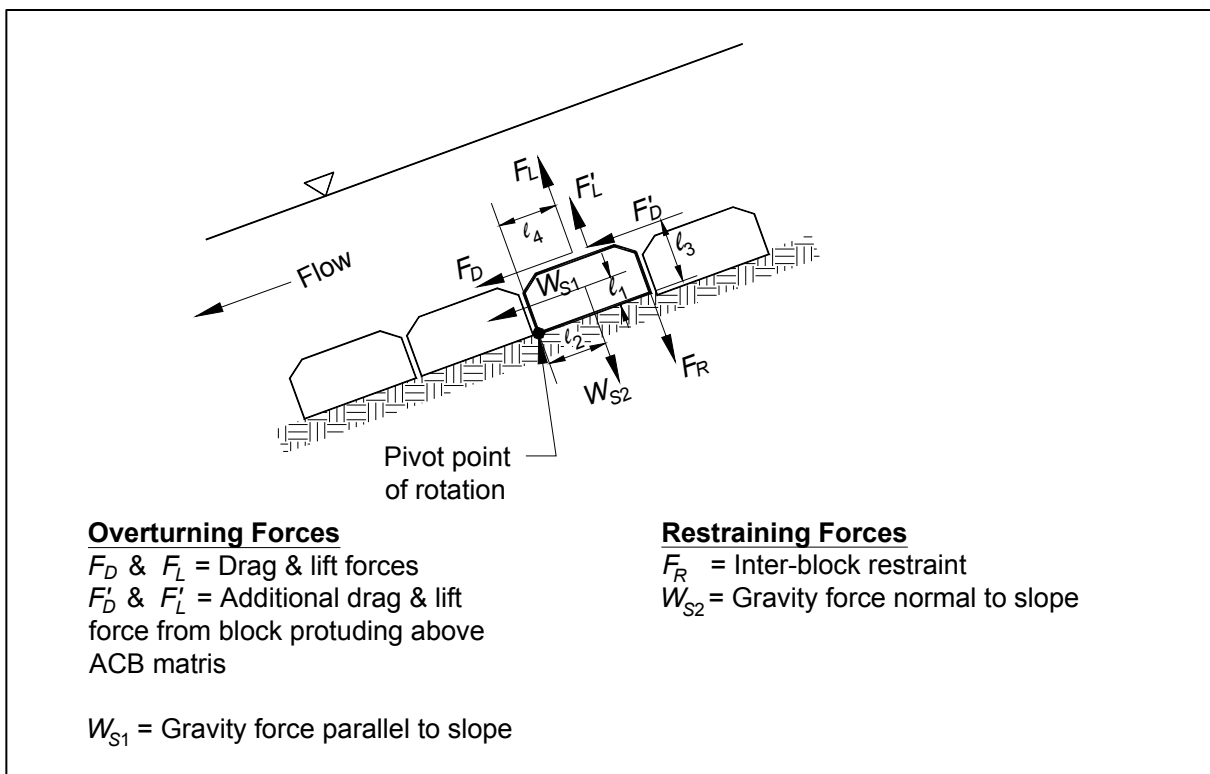

Figure 4.1—Moment balance on an ACB at incipient failure

A schematic of a typical laboratory flume is shown in Figure 4.2a, along with photographs of actual testing facilities in Figures 4.2b and 4.2c. Flume configurations vary greatly depending on the laboratory setting provided by the testing contractor, but are most commonly used for full scale testing of the blocks. Reference can be made to the annotated bibliography provided at the end of this ACB Design Manual for further documentation on laboratory flume testing of ACB systems.

4.2 Extrapolation of Test Data

Often, laboratory flume testing of ACB systems is conducted using a steep bed slope. In order to use the design procedure that follows, the critical shear stress for a horizontal surface must be known. An equation for extrapolation of test results from a steeper bed slope to results for a shallower bed slope has been developed. The equation is based on a moment balance approach that assumes inter-block restraint to be the same for the tested and untested configurations. The following equation is suggested for extrapolation of test results obtained from a steeper bed slope to that of a shallower bed slope for the same ACB system:

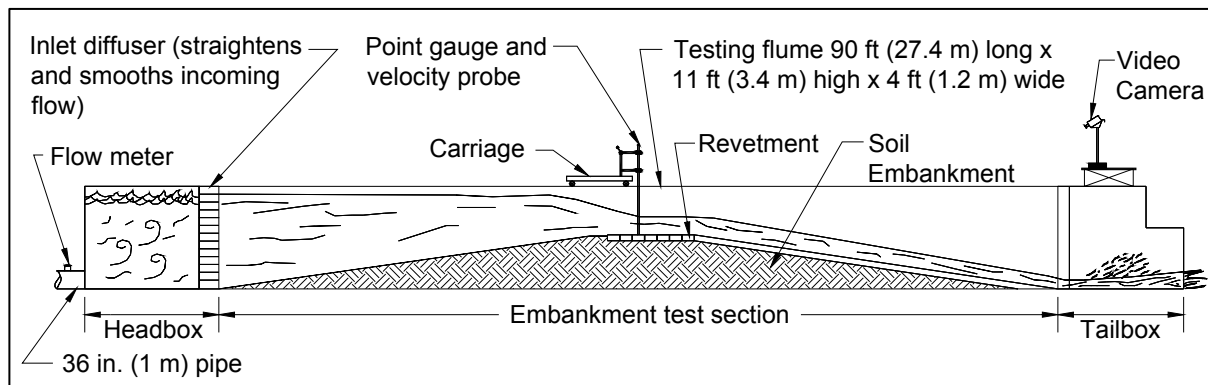

Figure 4.2a—Schematic of a typical laboratory flume for ACB performance testing



Figure 4.2b—Photograph of full-scale flume test (courtesy of Colorado State University)

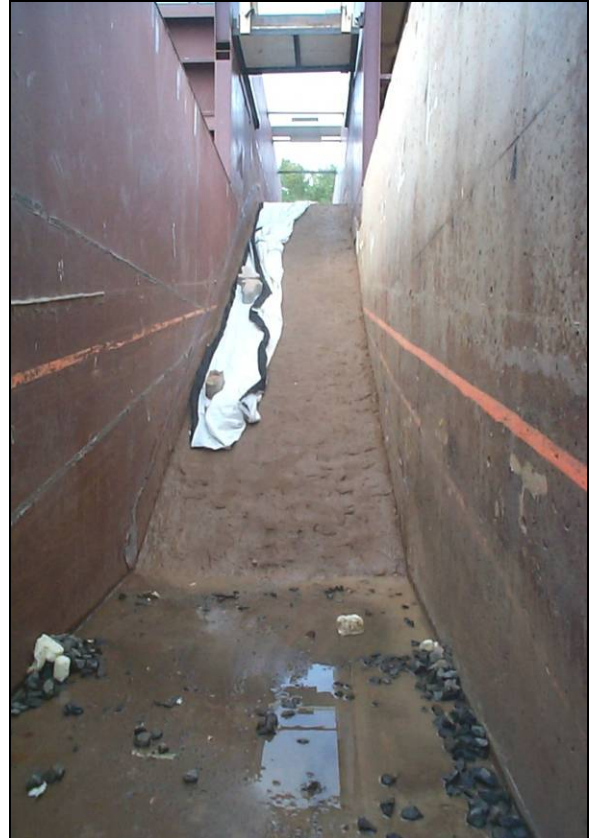

Figure 4.2c—Photograph of subgrade inspection after a series of full-scale tests (courtesy of Colorado State University)

$$\tau_{C\theta U} = \tau_{C\theta T} \cdot \left(\frac{l_2 \cos \theta_U - l_1 \sin \theta_U}{l_2 \cos \theta_T - l_1 \sin \theta_T} \right) \quad (\text{Eqn. 4.2})$$

where:

- $\tau_{C\theta U}$ = Critical shear stress for untested bed slope, lb/ft²
- $\tau_{C\theta T}$ = Critical shear stress for tested bed slope, lb/ft²
- θ_U = Untested bed slope (degrees)
Where θ_U less than or equal to θ_T ; and where design velocity (V_{des}) less than or equal to the test Velocity (V_{max})
- θ_T = Tested bed slope (degrees)
- l_x = Moment arms, ft; Refer to Figure 4.4.

Note that the moment arms used in this equation should apply to the orientation of the block during testing and are not necessarily the same as those recommended later in this document for design.

Similar to extrapolation based on bed slope, an equation for extrapolating test results from a tested block to a thicker untested block has been developed for block of identical

characteristics (i.e., only different in thickness and weight, but having identical footprint area, geometry and interlock mechanism). Furthermore, the extrapolation is only applicable when considering a block thickness greater than that of the tested block thickness and should not be used for determining the characteristics of units with thicknesses less than the tested block. This equation is also based on a moment balance approach that neglects inter-block restraint. The following equation is suggested for extrapolation of test results from one block thickness to another within the same family:

$$\tau_{CU} = \tau_{CT} \cdot \left(\frac{W_{SU} \ell_{2U}}{W_{ST} \ell_{2T}} \cdot \frac{\ell_{3T} + \ell_{4T}}{\ell_{3U} + \ell_{4U}} \right) \quad (\text{Eqn. 4.3})$$

Note: Extrapolated critical shear stress, τ_{CU} , is only applicable when considering an untested block thickness greater than that of the tested block thickness.

where:

τ_{CU}	=	Critical shear stress for untested block, lb/ft ²
τ_{CT}	=	Critical shear stress for tested block, lb/ft ²
W_{SU} and W_{ST}	=	Submerged weight of untested and tested blocks, lb
ℓ_{XU} and ℓ_{XT}	=	Moment arms of untested and tested blocks, ft

Note that the moment arms used in this equation apply to the orientation of the block during testing and are not necessarily the same as those recommended later in the document for design.

4.3 Factor of Safety Design Equations

The following design equations quantify a factor of safety for application to an ACB system based on an approach that considers the hydraulic forces imposed on a single block. The procedure was originally presented in "Stability Analysis for Coarse Granular Material on Slopes" (ref. 34) for riprap design and has been modified in "Erosion and Sedimentation" (ref. 28) to account for the case of riprap placed on a steep longitudinal slope and a steep lateral side slope (e.g., a revetment system protecting the bank of an overtopping spillway). The ref. 28 equations are the most general formulation to date and can be applied to any hydraulic system where the water surface slope is approximately equal to the bed slope (i.e., gradually varied flow). These equations have been modified slightly for this procedure to consider the known geometric dimensions of concrete blocks and the critical shear stress determined from performance testing. "Protecting Embankment Dams with Concrete Block Systems," (ref. 22) first presented the process of adapting the factor of safety equations to ACB systems. The major adjustment to the equations is to use the known block geometry for the moment arms instead of having to make assumptions about the size and shape of individual particles that comprise rock riprap.

Changes have also been incorporated into the design procedure to account for the additional forces imposed on a block that protrudes above the surrounding ACB matrix due to local subgrade irregularities or imprecise placement. Because a slight disruption of intimate contact between a block and the subgrade constitutes failure, the equations do not account for the restraining forces due to cables. The potential restraining force imposed on the block matrix by cables is intentionally limited so that block-to-block articulation is permitted. Similarly, the additional stabilizing forces offered by vegetation and/or mechanical-anchoring devices are ignored in the procedure because such effects are difficult to quantify and are

assumed to be of limited value, which contributes to the design inherent conservatism of the modeling design approach presented in this manual.

The safety factor (SF) for a single block in the ACB system is defined as the ratio of restraining moments to the overturning moments. Rearranging Equation 4.1 and adding terms to account for a block placed on a three-dimensional surface, results in the following equation for SF:

$$SF = \frac{l_2 W_s a_0}{l_1 W_s \sqrt{1 - a_0^2} \cos \beta + l_3 F_D \cos \delta + l_4 F_L + l_3 F'_D \cos \delta + l_4 F'_L} \quad (\text{Eqn. 4.4})$$

The nomenclature, forces, dimensions, and angles in the equation for SF are presented in Figure 4.3. Dividing Equation 4.4 by $l_1 W_s$ and substituting terms yields the final form of the factor of safety equations as presented in Table 4.1. The equations can be used in any consistent set of units.

The submerged block weight, W_s , is the weight of the block after subtracting out the force of buoyancy. The moment arms l_1 , l_2 , l_3 , and l_4 are determined from the block dimensions shown in Figure 4.4. In the general case, the pivot point of overturning will be at the front corner of the block; therefore, the horizontal distance from the center of the block to the corner should be used for both l_2 and l_4 . Since the resultant of weight is through the block center of gravity, one half the block height should be used for l_1 . The drag force acts both on the top surface of the block (shear drag) and on the body of the block (form drag). Considering both elements of drag, eight-tenths the height of the block is considered a good estimate of l_3 .

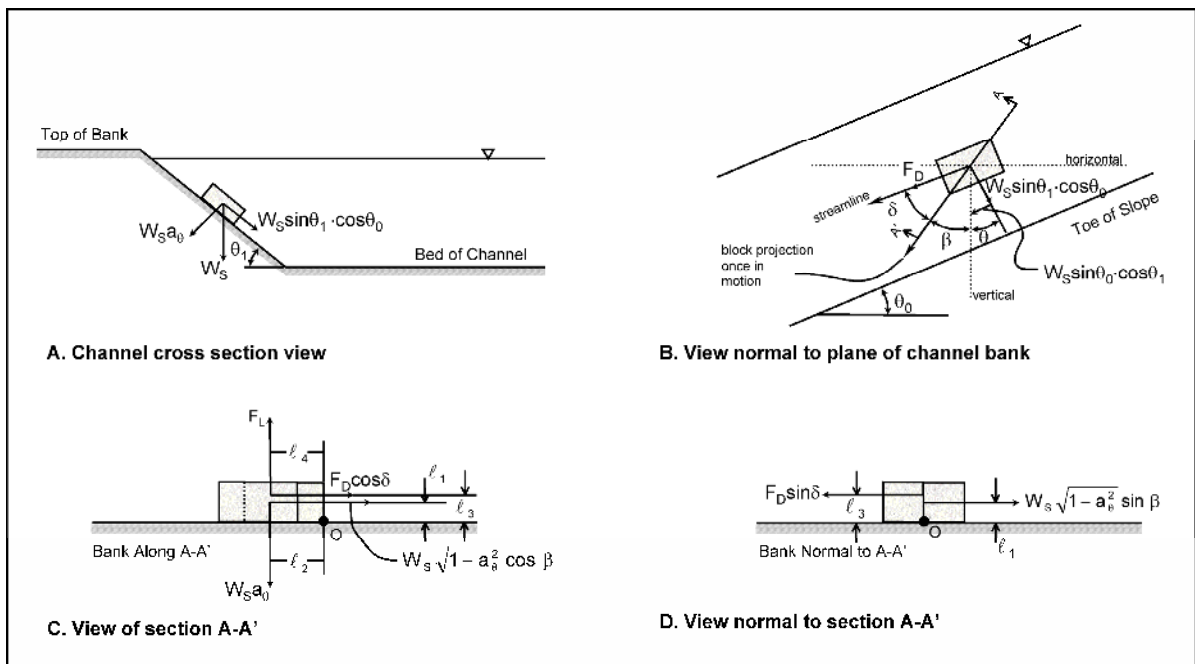

Figure 4.3—Three-dimensional view of a block on a channel side slope with factor of safety variables defined.

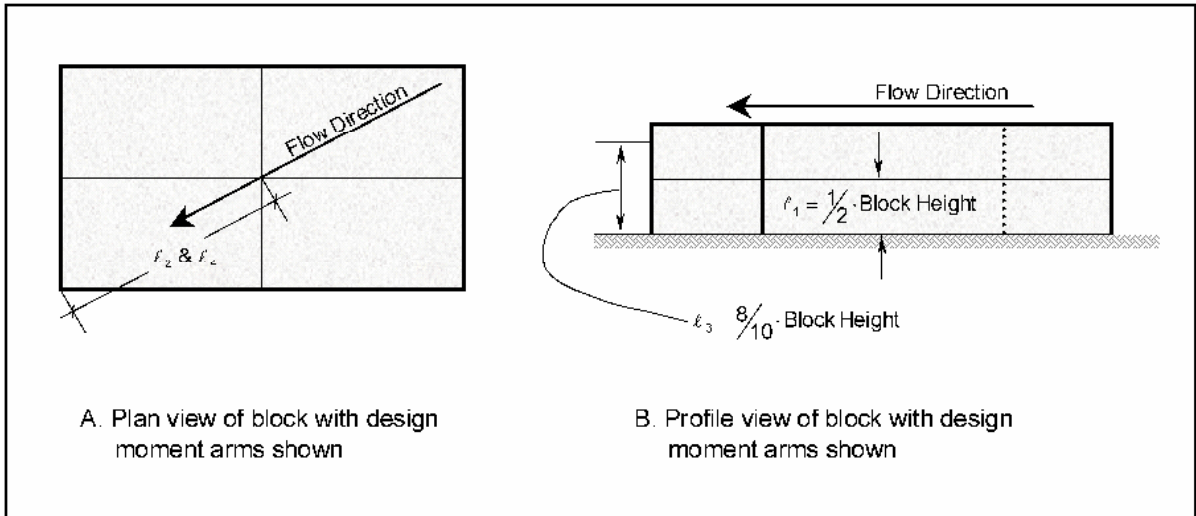

Figure 4.4—Figure of a block showing moment arms l_1 , l_2 , l_3 , and l_4 .

Extensive research has been conducted to determine the critical shear stress for virtually all sizes of granular soil particles and riprap, but there are limited test data available for proprietary ACB products. Therefore, critical shear stress for a block on a horizontal surface, τ_c , should come from performance testing of the ACB system being considered. Determination of design shear stress, τ_{des} , is discussed in Chapter 2.

Table 4.1—Design Equations for ACB Systems – Customary U.S. Units.

$SF = \frac{(\ell_2 / \ell_1) a_\theta}{\sqrt{1 - a_\theta^2} \cos \beta + \eta_1 (\ell_2 / \ell_1) + \frac{(\ell_3 F'_D \cos \delta + \ell_4 F'_L)}{\ell_1 W_S}}$	4.5a	a_θ = Projection of W_S into subgrade beneath block b = Block width, ft F'_D & F'_L = additional drag and lift forces, lb P_x = Block moment arms, ft S_C = Specific gravity of concrete (assume 2.1)
$\delta + \beta + \theta = 90^\circ \text{ or } \pi/2 \text{ radians}$	4.6a	SF = Calculated factor of safety V_{des} = Design velocity, ft/s (V_{des} less than or equal to V_{rest} or V_{max})
$\eta_1 = \left(\frac{\ell_4 / \ell_3 + \sin(\theta_0 + \theta + \beta)}{\ell_4 / \ell_3 + 1} \right) \eta_0$	4.7a	V_{max} = Maximum tested Velocity, ft/s W = Weight of block, lb W_S = Submerged weight of block, lb
$\beta = \arctan \left(\frac{\cos(\theta_0 + \theta)}{(\ell_4 / \ell_3 + 1) \frac{\sqrt{1 - a_\theta^2}}{\eta_0 (\ell_2 / \ell_1)} + \sin(\theta_0 + \theta)} \right)$	4.8a	ΔZ = Height of block protrusion above ACB matrix, ft β = Angle of block projection from downward direction, once in motion δ = Angle between drag force and block motion η_0 = Stability number for a horizontal surface
$\theta = \arctan \left(\frac{\sin \theta_0 \cdot \cos \theta_1}{\sin \theta_1 \cdot \cos \theta_0} \right) = \arctan \left(\frac{\tan \theta_0}{\tan \theta_1} \right)$	4.9a	η_1 = Stability number for a sloped surface θ = Angle between side slope projection of W_S and the vertical
$a_\theta = \sqrt{\cos^2 \theta_1 - \sin^2 \theta_0}$	4.10a	θ_0 = Channel bed slope (degrees or radians) (less than or equal to test bed slope) θ_1 = Channel side slope (degrees or radians)
$F'_L = F'_D = 0.5 \cdot (\Delta Z) b \rho V_{des}^2$	4.11a	Note - the equations cannot be solved for $\theta_1 = 0$ (i.e., division by 0); therefore, a negligible side slope must be entered for the case of $\theta_1 = 0$.
$\eta_0 = \frac{\tau_{des}}{\tau_C}$	4.12a	ρ = Mass density of water, 1.94 slugs/ft ³ τ_C = Critical shear stress for block on a horizontal surface, lb/ft ²
$W_S = W \cdot \left(\frac{S_C - 1}{S_C} \right)$	4.13a	τ_{des} = Design shear stress, lb/ft ²

4.4 Factor-of-Safety Methodology for ACB Design

There are several factors that need to be understood and considered when evaluating the appropriate target safety factor for design purposes. These can be categorized into two groups; “external” and “internal” factors. The external group consists of factors such as the complexity of the hydraulic system, the uncertainty of the input hydraulics, and the overall consequence of failure. The concepts behind these factors are well understood, even though calculating how each one of these considerations contributes to an overall target factor of safety can be very challenging. More commonly understood are the internal factors related directly to the safety factor methodology for ACB design. As discussed below, there are multiple facets of the safety factor methodology that are *inherently conservative* as they relate to external and internal design factors.

External Factors

- 1) Complexity of the hydraulic system and uncertainty of the input hydraulics – Obviously, all hydraulic systems are not of the same complexity. Modeling the flow characteristics of a stream bank or channel is much different than the design of scour protection around bridge piers. If the flow is relatively uniform and predictable, then a lower value for the target safety factor can be used for design. As the complexity of the system increases, so too should the sophistication of the model used to determine the hydraulic parameters. Utilizing a simplistic model in a complex environment may warrant an increase in the target safety factor (i.e. >1.5). Conversely, if a complex model is used to analyze a simplistic design scenario, then a lower target safety factor may be adequate (i.e. <1.5).
- 2) Consequence of failure – As with the complexity of the hydraulic system, the overall consequence of failure needs to be understood. Failure that results in loss of life is much different from a failure resulting in soil erosion along a stream bank in which no loss of life or property is imminent. Increasing the target safety factor is one way of potentially offsetting environmental conditions that are considered high risk.

Internal Factors

- 1) Conservatism associated with the safety factor methodology – The safety factor methodology is considered to be a conservative approach based on the following reasons:
 - a. Extrapolation of Test Data. In order to use the safety factor methodology, the critical shear stress of the unit along a horizontal surface must be understood and quantified. An equation is used for the extrapolation of test results from a steeper bed slope to a horizontal slope. A second extrapolation takes place from the tested units to thicker, untested units. In both processes, it is assumed that the intra-block restraint is the same for all thicknesses of the units. Under this assumption, the extrapolation equations only consider the weight and thickness of the units. This moment balance approach (obtained from the geometry of the unit) neglects any intra-block restraint. This assumption can be *very conservative* given the fact that thicker units have much more intra-block friction than thinner units given the shape of the blocks. As illustrated in Figure 4.5, the bottom half of an ACB unit is essentially a rectangle of concrete with adjacent units resting against six surrounding units. As the unit increases in thickness, so too does the intra-block friction.

Currently, the safety factor methodology does not account for this variable, which only increases the conservatism of this design approach for such conditions.

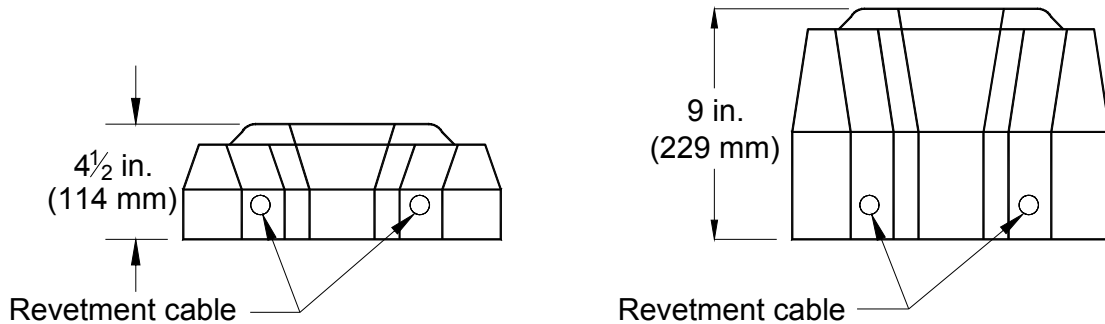

Figure 4.5 – Comparison between the potential intra-block friction between 4.5 in. (114 mm) and 9.0 in. (229 mm) ACB units. (courtesy of Submar, Inc. 805 S. Dunn St. Houma. LA 70360)

- b. Performance Values. Hydraulic testing on different “footprint” or classes of blocks and tapers for a variety of dam overtopping and spillway applications has been performed. In many of these tests, the testing facility was unable to fail the system under a 4 ft (1.2 m) and 5 ft (1.5 m) overtopping scenario. Nevertheless, the resulting shear stresses obtained from the tests are used within the safety factor methodology as a threshold, or failure, shear stress. This issue is compounded when extrapolating to thicker units. Without being able to reach a threshold condition in the testing flume, licensors and manufacturers extrapolate shear stress value from a stable value. A large degree of conservatism in the performance values of the units is the result of not being able to fail these systems under laboratory conditions.
- c. Interaction between Velocity and Shear Stress. In flume testing of the units, two of the most important results obtained are; 1. a stable shear stress; and 2. velocity at a downstream point under the highest flow conditions. Consider for example testing results whereby the highest boundary shear stress and velocity obtained was 22.2 lb/ft² (1,063 Pa) and 26.1 ft/s (7.96 m/s), respectively. In the safety factor methodology one utilizes a shear stress of 22.2 lb/ft² (1,063 Pa) regardless of the expected design velocity for every design utilizing this particular unit (provided that the design velocity is less than or equal to the tested velocity). Common “hydraulic” sense would state that if the velocity was only 12 ft/s (3.66 m/s) for a given application, then the system could withstand a much larger shear stress than 22.2 lb/ft² (1,063 Pa). Therefore, an additional degree of conservatism is present when the design velocity is less than the tested velocity and the design utilizes the maximum shear stress generated during the higher velocity event.
- d. Allowable shear stress in a vegetative state. All of the testing on existing ACB systems has taken place in a non-vegetative state. Many ACB applications for overtopping and spillway applications, however, seek a final system that is fully vegetated. A series of hydraulic tests conducted by the U.S. Army Corp of Engineers investigated the performance of identical ACB systems in both

vegetated and un-vegetated conditions (ref. 39). The end result was an increase in the allowable shear stress of 41% when vegetated.

Taking into consideration all of the points addressed above, what is the proper target safety factor required for a dam overtopping or spillway application? It is safe to state that the methodology used for ACB design is full of conservative assumptions. From the fact that tapered ACB systems have not reached their threshold condition in the testing flume to the fact that vegetation increases the allowable shear stress, it is apparent that the resulting safety factor can be conservative by 20 – 50%. Therefore, a target safety factor of 1.3 – 1.5 is adequate for applications in which the design hydraulics and site geometry are *clearly* understood, such as dam overtopping or spillway applications. *Ultimately, the “external” factors and overall design of the project will need to be evaluated and decided on by the engineer of record.* It may also be appropriate for an individual experienced in ACB design to offer an opinion on how these factors should be incorporated into an overall target safety factor.

4.5 Extent of Revetment Coverage

Longitudinal Extent—The revetment should be continuous for a distance that extends upstream and downstream of the region that experiences hydraulic forces severe enough to cause dislodging and/or transport of bed or bank material. The minimum distances recommended are an upstream distance of 1.0 channel width and a downstream distance of 1.5 channel widths. The channel reach that experiences severe hydraulic forces is usually identified by site inspection, examination of aerial photography, hydraulic modeling, or a combination of these methods.

Many site-specific factors have an influence on the actual length of channel that should be protected. Channel controls obstructions (such as bridge abutments) may produce local areas of relatively high velocity and shear stress due to channel constriction, but may also create areas of ineffective flow further upstream and downstream in "shadow zone" areas of slack water. In straight reaches, field reconnaissance may reveal erosion scars on the channel banks that will assist in determining the protection length required. In meandering reaches, because the natural progression of bank erosion is in the downstream direction, the present limit of erosion may not necessarily define the ultimate downstream limit. Guidance for the assessment of lateral migration is provided in HEC-20 (ref. 30). The design engineer is encouraged to review this reference for proper implementation.

Vertical Extent—The vertical extent of the revetment should provide ample freeboard above the design water surface. A minimum freeboard of 1.5 ft (0.5 m) should be used for unconstricted reaches and minimum of 2.5 ft (0.76 m) for constricted reaches. The freeboard height shall be taken above the energy grade line. The revetment system should either cover the entire channel bottom or, in the case of unlined channel beds, extend below the bed far enough so that the revetment is not undermined from local scour or degradation. Techniques for estimating local scour are provided in HEC-18, "Evaluating Scour at Bridges" (ref. 33) and long-term degradation is discussed in more detail in Chapter 3.

4.6 Cabled Versus Non-Cabled ACB Systems

Some manufacturers of ACB systems provide the option of cables or other connection devices for installation convenience and block-to-block connection. Under the precepts of the definition of failure and the factor of safety design procedure, cables are not considered to

increase the hydraulic stability of the ACB system and no explicit terms are incorporated into the procedure for block-to-block connections.

4.7 Drainage Layers

A drainage layer may be used in conjunction with an ACB system. A drainage layer lies between the blocks and the geotextile and/or granular filter. This layer allows "free" flow of water beneath the block system while still holding the filter material to the subsoil surface under the force of the block weight.

Drainage layers can be comprised of coarse, uniformly sized granular material, or can be synthetic mats that are specifically manufactured to permit flow within the plane of the mat. Granular drainage layers are typically comprised of 1- to 2-inch (25 to 51 mm) crushed rock in a layer 4 inches (102 mm) or more in thickness. The uniformity of the rock provides significant void space for flow of water. Synthetic drainage mats typically range in thickness from 0.25 to 0.75 inches (6 to 19 mm) and are manufactured using polymeric materials.

Many full-scale laboratory performance tests have been conducted with a drainage layer in place. When evaluating an ACB system, for which performance testing was conducted with a drainage layer and/or polymeric materials, a drainage layer and/or polymeric materials must also be used in the design and construction. *The drainage layers and/or polymeric materials tested dimensions are to be replicated in the field.* This recommendation is based on the apparent increase in the hydraulic stability of systems that have incorporated a drainage layer in the performance testing.

Vertical components of velocity in highly turbulent flow can create conditions where detrimental quantities of flow may penetrate beneath the block system in local areas. For this reason, the designer may wish to incorporate a drainage layer with any ACB system design in areas where very turbulent flows are expected.

ACBs installed over drainage layers can be used in a Best Management Practices (BMP) plan to preserve or improve existent sites, or in new developments. The system installed over a drainage layer preserves the natural drainage and treatment systems of the soil reducing the water runoff and flooding risks, improving water quality, reducing pollutants, recharging aquifers, and preventing erosion and when vegetated will also generate habitat. All the mentioned advantages make ACBs a great candidate for its use in sustainable projects where water quantity and quality control are extremely important.

Research done on permeable systems similar to ACBs with drainage layers has made known the excellent benefits on water quantity and quality control. A study in North Carolina (Ref. 40) demonstrated the ability of the system to reduce runoff and mitigate the peak flow, and to reduce water nutrients like total phosphorus (TP), ammonium-nitrogen (NH₄-N) and total Kjeldahl nitrogen (TKN). A similar study in Ireland (Ref. 41) also showed the ability of permeable systems over aggregate to remove heavy metals and hydrocarbons efficiently from industrial water.

4.8 ACB Design Procedure and Example

The following example illustrates an ACB design procedure that uses the factor of safety equations presented in Table 4.1. The procedure is presented in a series of steps that can be followed by the designer in order to select the appropriate ACB system based on a pre-

selected target safety factor. The major criterion for product selection is if the computed factor of safety for the ACB system meets or exceeds the pre-selected target value.

Problem Statement

A hydraulic structure is to be constructed at the downstream end of a reach on Meandering River, Texas. The river has a history of channel instability, both vertically and laterally. A quantitative assessment of channel stability has been conducted using the multi-level analysis from HEC-20, "Stream Stability at Highway Structures" (ref. 30). Using guidelines from HEC-23, "Bridge Scour and Stream Instability Countermeasures" (ref. 31), a drop structure has been designed at the indicated reach to control bed elevation changes. However, there is concern that lateral channel migration will threaten the integrity of the structure. An ACB system is proposed to arrest lateral migration. Figure 4.6 illustrates this design example problem. The design example presented in the following discussion uses inch-pound units, however, the design would proceed identically when using S.I. units.

The design discharge for the revetment is the 100-year event, which is 6,444 ft³/s. The bed slope of the reach upstream of the proposed drop structure is 0.01. The bed material is clay and the bank material is silty clay with sand.

The design procedure assumes that appropriate assessment of hydraulic and geomorphic conditions has been made prior to the design process. The HEC-RAS package has been used to model the design hydraulics for the reach upstream of the proposed drop structure. Table 4.2 presents pertinent results from the hydraulic model at the cross-section that is exposed to the most severe hydraulic conditions.

Channel Discharge (ft ³ /s)	6,444
Cross-Section-Averaged Velocity (ft/s)	8.1
Hydraulic Radius (ft)	4.3
Energy Grade Line or Bed Slope (ft/ft)	0.007

A horizontal velocity distribution was calculated at the critical (most severe) section using HEC-RAS. Figure 4.7 presents a reduced form of the velocity distribution with 9 velocity subsections derived from the HEC-RAS analysis, which originally calculated a distribution of 20 velocity subsections. The distribution indicates that the maximum velocity expected at the bend is 11.0 ft/s, which will be used as the design value in the factor of safety calculations. The cross-section-averaged shear stress can be calculated with Equation 2.1 as $\tau_0 = \gamma R S_f = 62.4(4.3)(0.007) = 1.9 \text{ lb/ft}^2$.

Chapter 2 provides guidance for increasing cross-section-averaged shear stress at meander bends. For this example, the velocity distribution in Figure 4.7 can be used instead, knowing that shear stress is proportional to the square of velocity. The maximum shear stress for design can be estimated as follows:

$$\tau_{\max} = \tau_0 \cdot \left(\frac{V_{\text{des}}}{V_{\text{avg}}} \right)^2 = 1.9 \cdot \left(\frac{11.0}{8.1} \right)^2 = 3.5 \text{ lb/ft}^2 \quad (\text{Eqn. 4.14})$$

Verify that V_{des} and V_{avg} are less than or equal to V_{max} determined during full-scale flume testing and used to define the critical shear stress of the revetment systems (τ_c)

For this example, the estimated maximum shear stress is used as the design value ($\tau_{des} = \tau_{max}$).

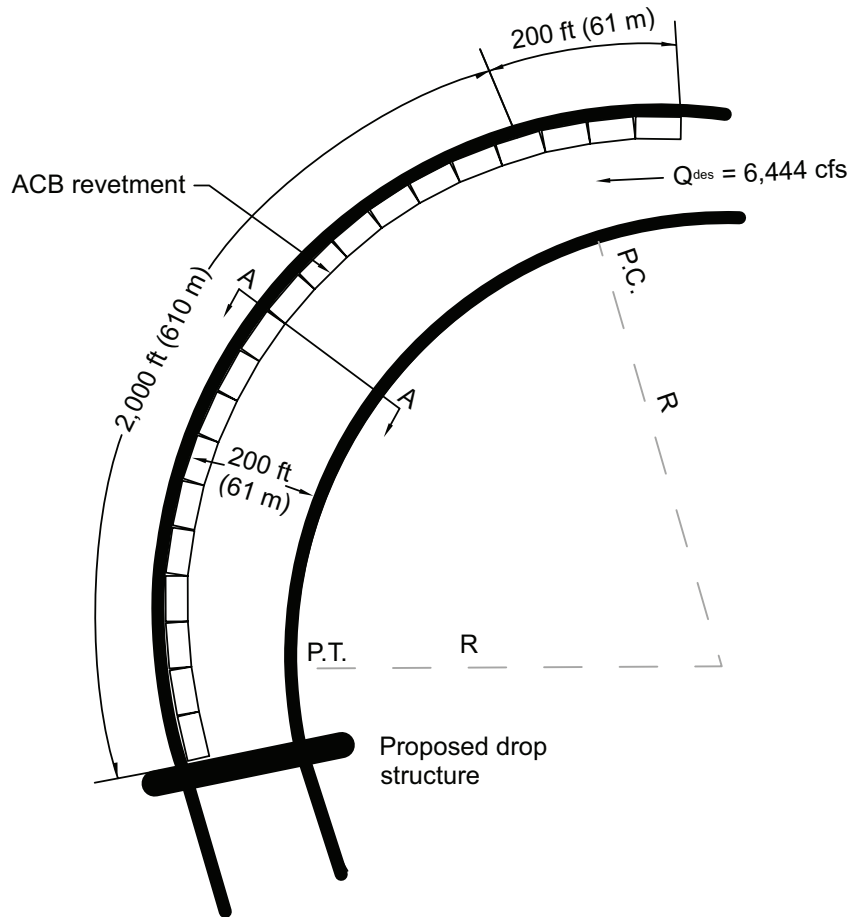

(A) Plan view of problem setting and ACB system installation

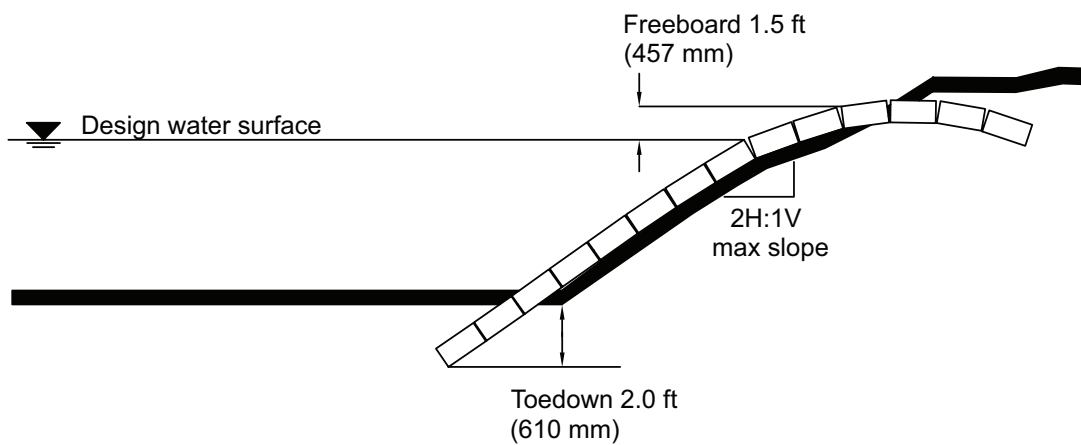

(B) Cross section view of A-A looking downstream

Figure 4.6—Example problem setting and ACB installation (not to scale).

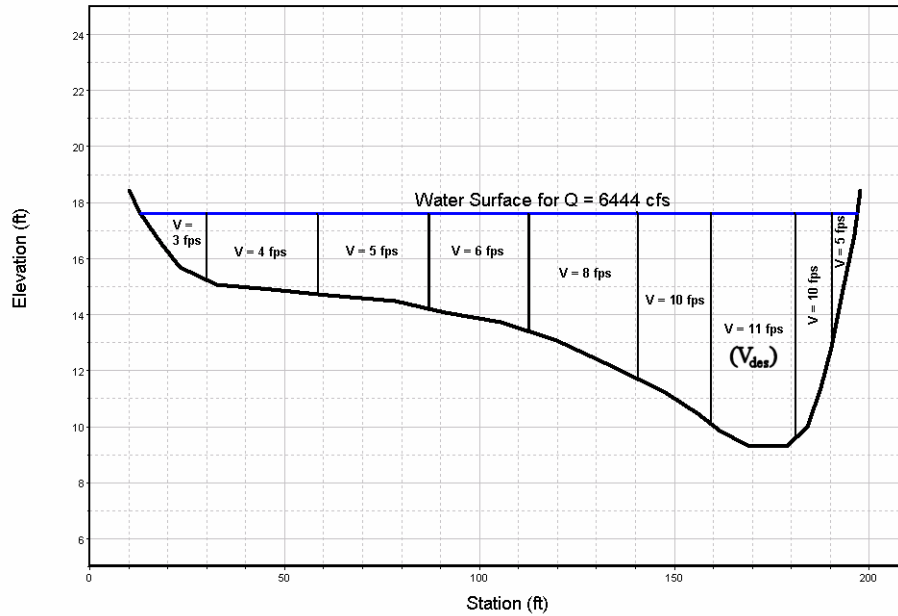

Figure 4.7—Velocity Distribution at Critical Cross-Section from HEC-RAS Model.

The suggested design procedure follows.

Step 1. Select a target factor of safety

For this example a target safety factor of 2.4 is selected. This safety factor was selected by the design engineer based on consideration of the project’s complexity and flow characteristics, consequences of failure, and overall understanding of the site conditions and modeling accuracy.

Step 2. Select potential ACB products for design

Contact ACB manufacturers and/or review ACB catalogs and select several systems that are appropriate for the given application based on a preliminary assessment of the hydraulic conditions. At the same time obtain the block properties necessary for design. These properties generally include the moment arms in Figure 4.4, the submerged weight of the block, the critical shear stress for the block on a horizontal surface, the maximum test velocity, and the test bed slope.

For this example, two products from ACB Systems, Inc. are selected based on guidance from the manufacturer. ACB Systems, Inc. suggests that the Type-A or Type-B blocks would be appropriate for velocities in the range of 10 to 15 ft/s. The block properties provided by the manufacturer are shown on the worksheet accompanying this design example.

Step 3. Calculate the factor of safety for each product

Use Worksheet 1 from Chapter 8 to assist in the factor of safety calculations using the equations from Table 4.1. For this example the calculations are presented for the Type-A block and a completed worksheet with both blocks is included.

a) Assuming a specific gravity of 2.1 for the concrete, calculate the submerged unit weight:

$$W_s = W \cdot \left(\frac{S_c - 1}{S_c} \right) \quad (\text{see Eqn. 4.13})$$

$$W_s = 66.0 \cdot \left(\frac{2.1 - 1}{2.1} \right) = 34.6 \text{ lb}$$

b) Calculate the stability number on a horizontal surface:

$$\eta_0 = \frac{\tau_{des}}{\tau_c} \quad (\text{see Eqn. 4.12})$$

$$\eta_0 = \frac{3.5}{25.0} = 0.14$$

c) Calculate the additional lift and drag forces from block protrusion out of the ACB matrix:

$$F'_L = F'_D = 0.5 \cdot (\Delta Z) b \rho V_{des}^2 \quad (\text{see Eqn. 4.11})$$

Note: The design velocity shall be less than or equal to the maximum test velocity used in full-scale hydraulic testing.

$$F'_L = F'_D = 0.5(0.04)(1.25)(1.94)(11.0)^2 = 5.87 \text{ lb}$$

d) Calculate a_θ :

$$a_\theta = \sqrt{\cos^2 \theta_1 - \sin^2 \theta_0} \quad (\text{see Eqn. 4.10})$$

$$a_\theta = \sqrt{\cos^2(26.57) - \sin^2(0.57)} = 0.8943$$

e) Calculate angle θ :

$$\theta = \arctan\left(\frac{\sin\theta_0 \cdot \cos\theta_1}{\sin\theta_1 \cdot \cos\theta_0}\right) = \arctan\left(\frac{\tan\theta_0}{\tan\theta_1}\right) \quad (\text{see Eqn. 4.9})$$

$$\theta = \arctan\left(\frac{\sin(0.57) \cdot \cos(26.57)}{\sin(26.57) \cdot \cos(0.57)}\right) = 1.14 \text{ degrees}$$

f) Calculate angle β :

$$\beta = \arctan\left(\frac{\cos(\theta_0 + \theta)}{\left(\ell_4 / \ell_3 + 1\right) \frac{\sqrt{1 - a_0^2}}{\eta_0 (\ell_2 / \ell_1)} + \sin(\theta_0 + \theta)}\right) \quad (\text{see Eqn. 4.8})$$

$$\beta = \arctan\left(\frac{\cos(0.57 + 1.14)}{\left(0.88 / 0.33 + 1\right) \frac{\sqrt{1 - 0.8943^2}}{0.14(0.88 / 0.21)} + \sin(0.57 + 1.14)}\right) = 19.48 \text{ degrees}$$

g) Calculate the stability number on a sloped surface:

$$\eta_1 = \left(\frac{\ell_4 / \ell_3 + \sin(\theta_0 + \theta + \beta)}{\ell_4 / \ell_3 + 1}\right) \eta_0 \quad (\text{see Eqn. 4.7})$$

$$\eta_1 = \left\{ \frac{0.88 / 0.33 + \sin(0.57 + 1.14 + 19.48)}{0.88 / 0.33 + 1} \right\} 0.14 = 0.11$$

h) Calculate angle δ :

$$\delta + \beta + \theta = 90^\circ \text{ or } \pi/2 \text{ radians} \quad (\text{see Eqn. 4.6})$$

$$\delta = 90 - (19.48 + 1.14) = 69.38 \text{ degrees}$$

i) Calculate the actual factor of safety for the Type-A block under these hydraulic conditions:

$$SF = \frac{(\ell_2 / \ell_1) a_0}{\sqrt{1 - a_0^2} \cos \beta + \eta_1 (\ell_2 / \ell_1) + \frac{(\ell_3 F'_D \cos \delta + \ell_4 F'_L)}{\ell_1 W_s}} \quad (\text{see Eqn. 4.5})$$

$$SF = \frac{(0.88 / 0.21) 0.8943}{\sqrt{1 - 0.8943^2} \cos(19.48) + 0.11(0.88 / 0.21) + \frac{(0.33(5.87) \cos(69.38) + 0.88(5.87))}{0.21(34.6)}} = 2.2$$

Steps a) through i) are then repeated for the Type-B block, the results of which are shown in the accompanying worksheet to this design example.

Step 4. Assess the suitability of each product and select a final ACB System

Compare the calculated factors of safety for the considered blocks with the design factor of safety and select the product that best meets the design needs. Other factors for consideration are: 1) *the blocks open area relative to vegetative potential and manning's n variation*; 2) *the block's ability to articulate*; 3) *the block's ability to expand and contract*; 4) *block interlock and tapering characteristics*. For this example the Type B product is the only choice because the alternative did not satisfy the target factor of safety. Once a product has been selected, the block specifications at the bottom of the worksheet are entered.

Worksheet 1 - ACB Design and Selection

Project Information

Company: ACB Consultants, Inc.
 Designer: John Doe Date: 1/10/10
 Project Name/Number: 10-466-077
 Client: Harris County, TX
 Target Factor of Safety: 2.4

Site Information

Description: Meandering River
 Bed Slope (ft/ft): 0.01 (degrees): 0.57
 Side Slope (H/V): 2.0 (degrees): 26.57

Additional Comments

Hydraulic design data comes from critical design section obtained through HEC-RAS model

Hydraulic Design Data

Discharge (cfs): 6444 Description: 100-Yr
 Velocity (ft/s): 11.0 Flow Depth (ft): 4.3
 Friction Slope (ft/ft): 0.007000
 Design Shear Stress (lb/ft²): 3.5

Factor of Safety Calculations from Table 4.1

Variables in SF Calculation	ACB Systems for SF Calculation					
	Type-A	Type-B				
Tested bed slope (degrees)	26.57	26.57				
Max. tested velocity (ft/s)	18	20				
W (lb)	66.0	72.9				
W _s (lb)	34.6	38.2				
b (ft)	1.25	1.25				
ℓ ₁ (ft)	0.21	0.21				
ℓ ₂ & ℓ ₄ (ft)	0.88	0.98				
ℓ ₃ (ft)	0.33	0.33				
τ _c (lb/ft ²)	25.0	30.0				
η ₀	0.14	0.12				
ΔZ (ft)	0.04	0.04				
F' _L & F' _D (lb)	5.87	5.87				
a ₀	0.8943	0.8943				
θ (degrees)	1.14	1.14				
β (degrees)	19.48	17.34				
η ₁	0.11	0.10				
δ (degrees)	69.38	71.52				
SF	2.2	2.5				
Bed Slope: Tested ≥ Application??	2.0 ≥ 0.01 OK	2.0 ≥ 0.01 = OK				
Velocity: Max tested ≥ Design??	18 ≥ 11 = OK	20 ≥ 11 = OK				

Manufacturer/Selected ACB System

ACB Systems, Inc./Class Type-B

Critical Shear Stress (lb/ft²): 30.0
 Calculated Factor of Safety: 2.5
 Block Weight (lb): 72.9

Block Width (in.): 15
 Block Length (in.): 18
 Block Height (in.): 5
 Acceptable Protrusion (in.): 0.5

Step 5. Design horizontal and vertical extent of the ACB system

Following guidelines from Section 4.5, the ACB system should terminate against the drop structure and extend 2200 ft (671 m) upstream, which is more than one channel width beyond the observed limits of channel erosion. The drop structure is expected to arrest vertical degradation; therefore, bed erosion is not expected to undermine the revetment. A toe down into the bed of 2 ft is specified so that lateral movement of the lowest point in the channel will not undermine the revetment. The specified freeboard for this application is 1.5 ft (45.72 cm) above the water surface profile computed in the HEC-RAS model. *The maximum side slope for any ACB system should be 2H:1V.*

Step 6. Design the filtration component of the ACB system

The procedure outlined in Chapter 5 should be followed for filtration design. A worked example problem is provided in Section 5.5 to illustrate the procedure. If performance testing of the selected ACB system was conducted with a drainage layer in place, then a drainage layer of the same type is required for the design.

5.0 GEOTEXTILE AND GRANULAR FILTER DESIGN

The importance of the filter component of an ACB system should not be underestimated. If laboratory testing of an ACB system was conducted with a filter in place, then the design should include a filter. Geotextiles and granular layers perform the filtration function. Some situations call for a composite filter consisting of both a granular layer and a geotextile. The specific characteristics of the existing base soil determine whether a granular filter is required.

The filter is installed between the ACB and the base soil (Figure 5.1). The primary role of a filter component is to retain the soil particles while allowing the flow of water through the interface between the ACB system and the underlying soil. A granular filter also provides a smooth and free-draining surface to rocky or otherwise irregular subgrades, thereby maximizing intimate contact between the ACB system and its base. The need for granular material is fully addressed in the installation section. Careful design, selection, and installation of the appropriate filter material all play an important role in the overall performance of ACB systems.

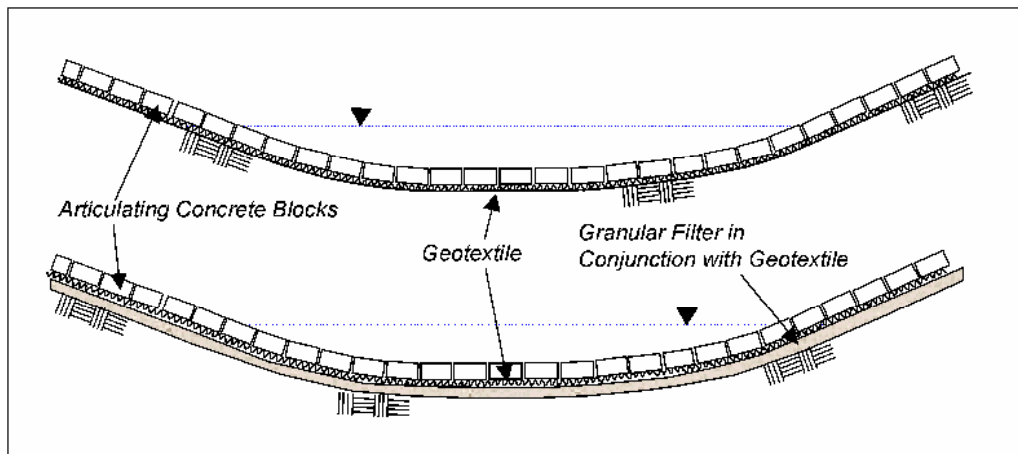

Figure 5.1—Channel cross-sections showing filter and bedding orientation.

5.1 Filter Functions

The primary function of filter components is to prevent fine particles from washing away while allowing water flow through the filter material. These two contrary objectives must be considered to achieve an effective functional balance between retention and permeability.

Filters assist in maintaining intimate contact between the revetment and the subgrade by providing stability at the interface. Depending upon the internal stability of the soil, several processes can occur over time along the interface of the base soil and filter material. The filter pore size and the base soil stability dictate these processes. As an example, consider the process of "piping." Piping is basically the washing away of very fine particles, resulting in greater void space in the soil structure. Piping is more likely to occur in non-cohesive/unstable soils that are in contact with a filter material that has large openings. The large openings do not retain the smaller particles and therefore these particles are removed by flowing water and only the larger particles remain. This process increases the potential for soil erosion by weakening the soil structure. Correct filter design reduces the effects of piping by limiting the loss of fines. Figure 5.2 illustrates a stable versus unstable soil and several common filtering processes that can occur (modified from Koerner 1997, ref. 29). The large arrows in Figure 5.2 indicate the direction of flow.

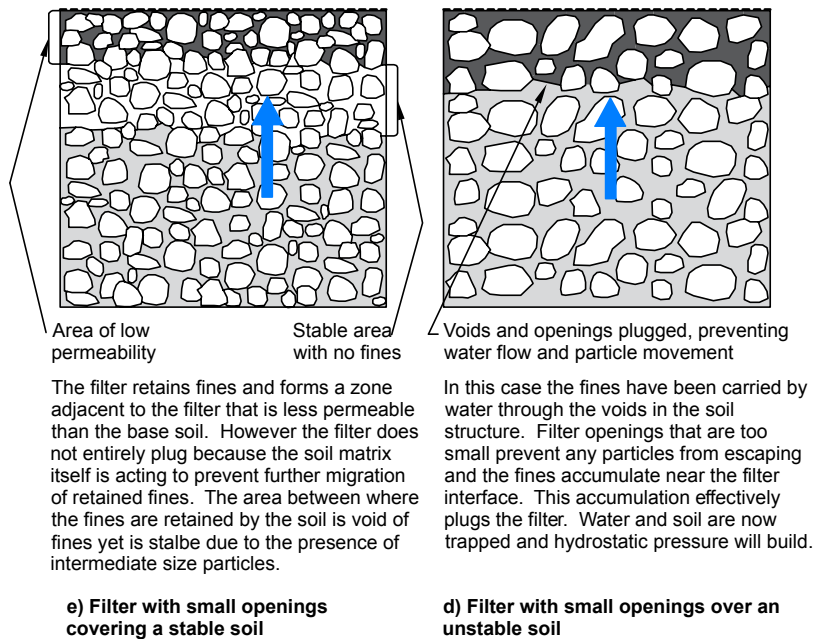
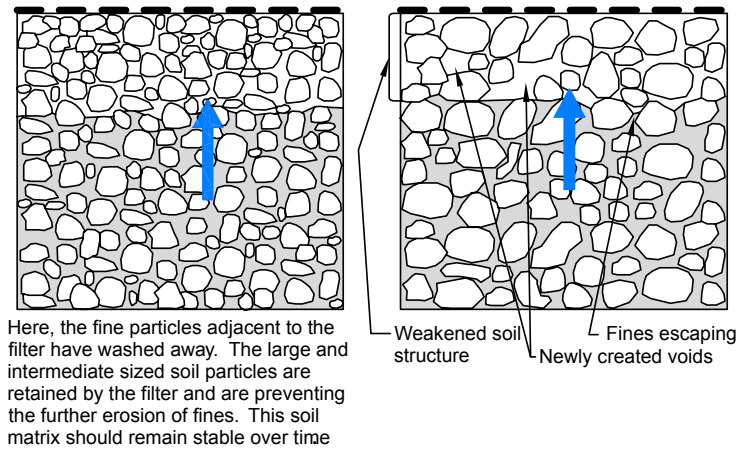
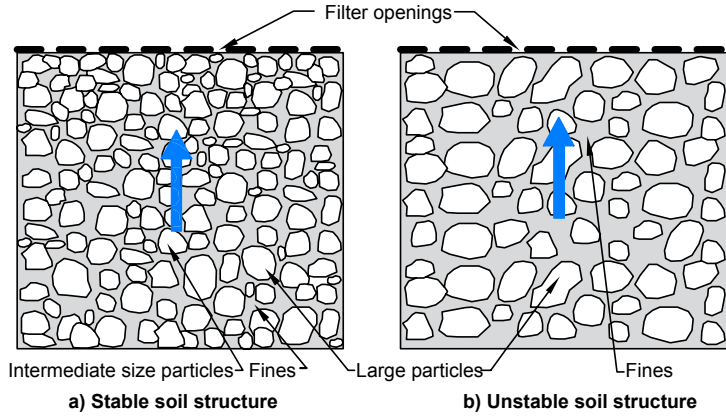

Figure 5.2—Examples of soil and filter subgrades

As illustrated in Figure 5.2, matching the correct filter opening to the characteristics of the base soil is critical to obtaining the desired retention of the filter component.

Filters should be permeable enough to allow unimpeded flow of water through the filter material. This is necessary for two reasons: regulation of the filtration process along the base soil and filter interface, as illustrated above, and reduction of hydrostatic pressure build-up from local groundwater fluctuations in the vicinity of the channel bed and banks (e.g., seasonal water level changes and storm events) that can weaken the channel soil structure. The permeability of the filter should never be less than the layer below it (whether base soil or another filter layer).

Figure 5.3 illustrates a process that can result in an increase of hydrostatic pressure beneath the filter. The figure is a time series view of channel cross-sections showing changing water levels and seepage resulting from a storm event. A properly designed filter will help alleviate problems associated with fluctuating water levels.

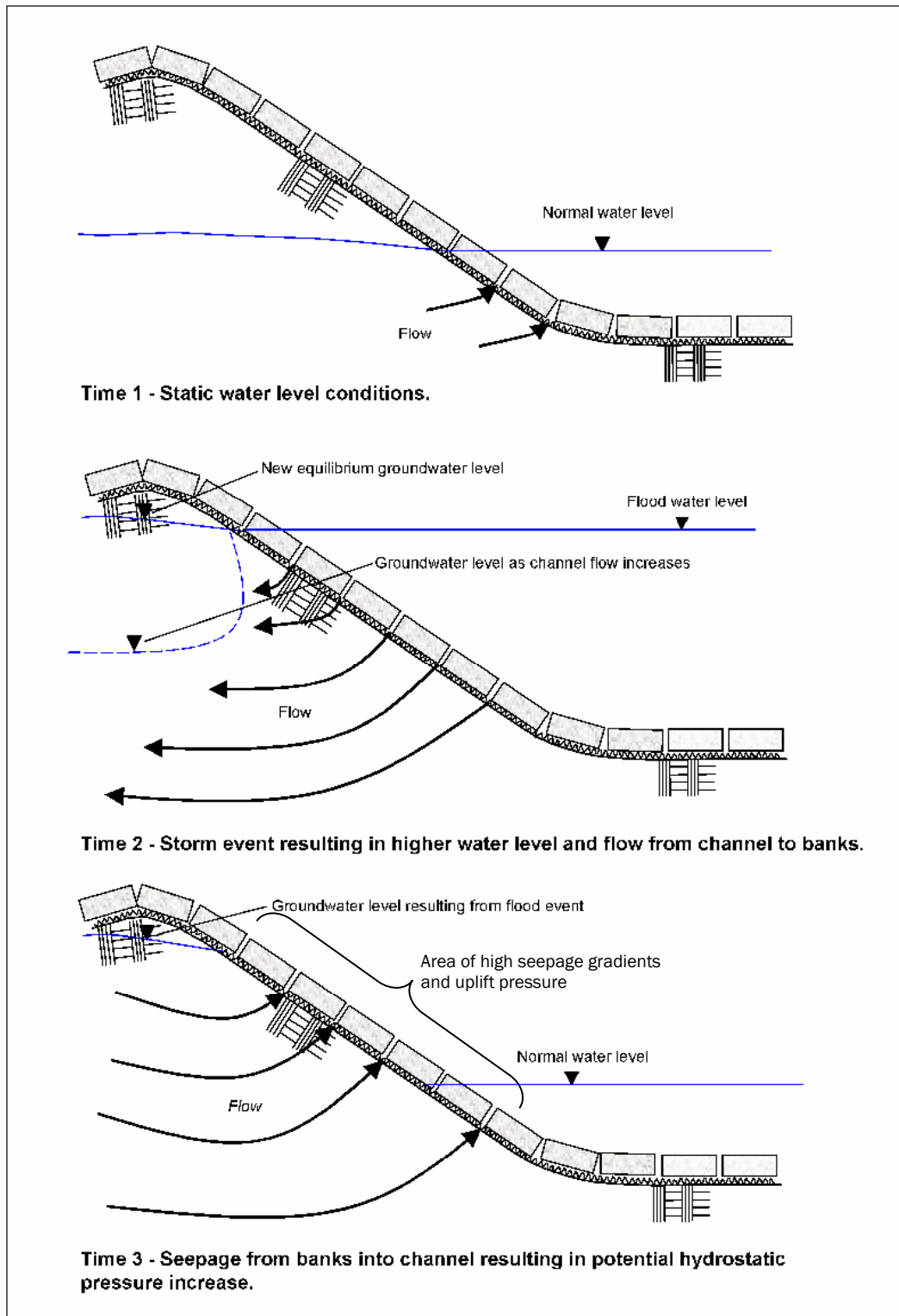

Figure 5.3—Time series of channel and groundwater level changes due to a flood event.

5.2 Base Soil Properties

Base soil is defined here as the subgrade material upon which the filter or the ACB system will be placed. Base soil can be existing material of the channel bed and banks, or imported and recompacted fill. The following properties represent a minimum level of information that should be obtained for the base soil for use in the design process:

General Soil Classification. Soils are classified based on laboratory determinations of particle size characteristics and the physical effects of varying water content on soil properties. Typically, soils are described as coarse-grained if more than 50 percent by weight of the particles are larger than a #200 sieve (0.075 mm mesh), and fine-grained if more than 50 percent by weight is smaller than this size. Sands and gravels are examples of coarse-grained soils, while silts and clays are examples of fine-grained soils.

The fine-grained fraction of a soil is further described by changes in its consistency caused by varying water content and by the percentage of organic matter present. Soil classification methodology is described in ASTM D2487 "Standard Practice for Classification of Soils for Engineering Purposes (Unified Soil Classification System)" (ref. 5).

Particle Size Distribution. The single most important soil property for the design of ACB systems is the range of particle sizes in the soil. Particle size is a convenient and relatively simple way to assess soil properties. Also, particle size tends to be an indication of other properties such as permeability. Characterizing soil particle size involves determining the relative proportions of sand, silt, and clay in the soil. This characterization is usually done using either a technique called sieve analysis for coarse-grained soils or sedimentation (hydrometer) analysis for fine-grained soils. ASTM D422 "Standard Test Method for Particle-Size Analysis of Soils" (ref. 2) outlines these standardized procedures.

Plasticity. Plasticity is defined as the property of a material that allows it to be deformed rapidly, without rupture, without elastic rebound, and without volume change. A measure of plasticity is the Plasticity Index (PI), which should be determined for soils with a large percentage of fines or clay particles. The results associated with plasticity testing are referred to as the Atterberg Limits. ASTM D4318 "Standard Test Methods for Liquid Limit, Plastic Limit, and Plasticity Index of Soils" (ref. 7) defines these testing procedures.

Porosity. Porosity is that portion of a representative volume of soil that is interconnected void space. It is typically reported as a dimensionless fraction or a percentage. The porosity of soils is affected by the particle size distribution, the particle shape (e.g., round vs. angular), and degree of compaction and/or cementation.

Permeability. Permeability is a measure of the ability of soil to transmit water. Permeability is related to particle size distribution, dominated by the finest 20 percent, and can be determined using an equation that has been developed for this purpose or through laboratory analysis. ASTM provides two standard test methods for determining permeability: ASTM D2434 "Standard Test Method for Permeability of Granular Soils (Constant Head)" (ref. 4) or ASTM D5084 "Standard Test Method for Measurement of Hydraulic Conductivity of Saturated Porous Materials Using a Flexible Wall Permeameter" (ref. 13). Soil permeability is used as part of the design process to help select an appropriate filter material.

For granular soils, the permeability may be estimated by the Fair-Hatch Equation in lieu of performing laboratory testing. The Fair-Hatch Equation relates permeability to soil porosity

and the particle size distribution. Porosity is defined as the ratio of void space to the total volume of the soil. The pores in the soil are the means by which water is conducted; therefore, permeability of soil is influenced by the soil porosity. The Fair-Hatch Equation is:

$$K_s = 1.958 \times 10^6 \frac{\phi^3}{(1-\phi)^2} \left(\frac{1}{49 \left(\sum_{n=1}^N \frac{P_n}{d_n} \right)^2} \right) \quad (\text{Eqn. 5.1})$$

where:

- K_s = Soil permeability, cm/s
- ϕ = Dimensionless soil porosity determined from Equation 5.2 or Table 5.1, both shown below
- P = Percentage of material in the distribution between adjacent particle sizes
- d = Geometric mean of adjacent particle sizes in the distribution, mm
- N = Number of intervals between adjacent particle sizes

If the particle size distribution does not include a particle size at 0 percent, this value should be estimated by extrapolation and included in the calculation. This is important because the presence of small particles representing the fine end of the particle size distribution significantly influences permeability.

Commonly observed values of porosity and permeability for alluvial soils are presented in Table 5.1. If the soil has been compacted in place rather than naturally deposited, the following equation that relates porosity to compaction and dry unit weight of the soil is recommended:

$$\phi = 1 - \left(\frac{C}{100} \cdot \frac{\gamma_d}{165.4 \text{ lb/ft}^3} \right) \quad (\text{Eqn. 5.2})$$

where:

- ϕ = Soil porosity (dimensionless)
- C = Soil compaction in percent of Standard Proctor Density (90 to 100)
- γ_d = Maximum dry unit weight of the soil at 100 percent of Standard Proctor Density, lb/ft³

Type of Material	Porosity	Permeability (cm/s)
Gravel, coarse	0.28	4×10^{-1}
Gravel, fine	0.34	
Sand, coarse	0.39	5×10^{-2}
Sand, fine	0.43	3×10^{-3}
Silt	0.46	3×10^{-5}
Clay	0.42	9×10^{-8}

5.3 Geotextile Filter Properties

For compatibility with site-specific soils, geotextiles must exhibit the appropriate values of permittivity (hydraulic conductivity), pore size (otherwise known as Apparent Opening Size, or AOS), and porosity (or percent open area). In addition, geotextiles must be sufficiently strong to withstand the stresses during installation. Values of these properties are available from manufacturers.

Only woven monofilament or nonwoven needle-punched geotextiles should be considered for filter applications. Slit-film, spun-bonded, or other types of geotextiles are not suitable as filters. If a woven monofilament fabric is chosen, it should have a Percent Open Area (POA) greater than, or equal to, 4%. If a nonwoven needle-punched fabric is chosen, it should have a porosity greater than, or equal to 30%, and a mass per unit area of at least 12 ounces per square yard (400 grams per square meter). The following list briefly describes the most relevant properties of geotextiles for filter applications that are available from manufacturers. The ASTM standard test is cited where applicable.

Permittivity. This is a measure (used to compare geotextiles of various thicknesses) of a material's cross-plane permeability that when multiplied by the geotextile thickness gives a traditional permeability value. (ASTM D4491) (ref. 8)

Apparent Opening Size (AOS). Also known as Equivalent Opening Size, this measure is generally reported as O_{95} . O_{95} represents the aperture size such that 95 percent of the openings are smaller. In similar fashion to a soil gradation curve, a geotextile hole distribution curve can be derived. (ASTM D4751) (ref. 11)

Porosity. Porosity is a comparison of the total volume of voids to the total volume of geotextile. This measure is applicable to non-woven geotextiles only. Porosity is used to estimate the potential for long term clogging, and is typically reported as a percentage.

Percent Open Area (POA). POA is a comparison of the total open area to the total geotextile area. This measure is applicable to woven geotextiles only. POA is used to estimate the potential for long term clogging.

Thickness. As mentioned above, thickness is used to calculate traditional permeability based upon permittivity. It is typically reported in millimeters or mils (thousandths of an inch).

Grab Strength and Elongation. Force required to initiate a tear in the fabric when pulled in tension. Typically reported in Newtons or pounds as measured in a testing apparatus having standardized dimensions. The elongation measures the amount the material stretches before it tears, and is reported as a percent of its original (unstretched) length. (ASTM D4632) (ref. 10)

Tear Strength. Force required to propagate a tear once initiated. Typically reported in Newtons or pounds. (ASTM D4533) (ref. 9)

Puncture Strength. Force required to puncture a geotextile using a standard penetration apparatus. Typically reported in pounds or Newtons. (ASTM D4833) (ref. 12)

There are many other tests to determine various characteristics of geotextiles; only those deemed most relevant to applications involving countermeasures have been discussed here. As previously mentioned, geotextiles should be able to withstand the rigors of installation without suffering degradation of any kind. Long-term endurance to stresses such as ultraviolet solar radiation or continual abrasion are considered of secondary importance, because once the geotextile has been installed and covered by the armor layer, these

stresses do not represent the long-term environment that the geotextile will experience. Table 5.5 provides recommended tests and allowable values for various geotextile properties.

5.4 Granular Filter Properties

Generally speaking, most required granular filter properties can be obtained from the particle size distribution curve for the material. Granular filters serve as a transitional layer between a predominantly fine-grained base soil and a geotextile.

Particle size distribution. As a rule of thumb, the gradation curve of the granular filter material should be approximately parallel to that of the base soil. Parallel gradation curves minimize the migration of particles from the finer material into the coarser material. HEC-23, "Bridge Scour and Stream Instability Countermeasures" (ref. 31) proposes a procedure originally developed by Cistin and Ziems whereby the d_{50} size of the filter is selected based on the coefficients of uniformity (d_{60}/d_{10}) of both the base soil and the filter material. With this method, the grain size distribution curves do not necessarily need to be approximately parallel.

Permeability. Refer to Section 5.2 for an explanation of permeability. Often, the permeability for a granular filter material is estimated by the Fair-Hatch equation or determined by laboratory analysis. The permeability of a granular layer is used to select a geotextile when designing a composite filter. The permeability of the filter should be at least 10 times the permeability of the soil.

Thickness. Practical issues of placement suggest that a typical minimum thickness of 6 to 8 inches (152 to 203 mm) be specified. For placement under water, thickness should be increased by 50 percent.

Quality and Durability. Aggregate used for a granular filter should be hard, dense, and durable.

5.5 Filter Design Procedure and Example

The following example illustrates a six-step design procedure for the filter component of an ACB system. The major criteria for geotextile and granular filter design are permeability and retention, which need to be compatible with the base soil.

Problem Statement:

A filter needs to be designed for the ACB system that was designed in Section 4.8 for Meandering River, Texas. See Section 4.8 for an overall description of the site and the need for the ACB System. Tables 5.2 and 5.3 provide the needed soil properties from geotechnical laboratory testing for this example problem.

Sample ID	No. 3 (in Channel)
Test Date	6/18/09
Soil description	Silty Clay with Sand
USCS Classification	CL-ML
Moisture Content	9.9%
Liquid Limit (LL)	26%
Plastic Limit (PL)	19%
Plasticity Index (PI)	7%
Permeability	7.5×10^{-7} cm/s

Sieve Size	Particle Size (mm)	Percent Finer
3/4 inch	19.05	100.0
1/2 inch	12.70	100.0
3/8 inch	9.52	100.0
No. 4	4.75	100.0
No. 10	2.00	100.0
No. 20	0.85	99.8
No. 40	0.425	99.6
No. 80	0.180	99.6
No. 100	0.150	99.0
No. 200	0.075	71.9
0.005 mm	0.005	24.2

The suggested design procedure follows.

Step 1. Obtain base soil information

Section 5.2 can be consulted for a definition of common soil properties. Typically, the necessary base soil information is a grain size distribution curve, permeability, and the Plasticity Index (PI is required only if the base soil is more than 20 percent clay). Worksheet 2 from Chapter 8 can be used to plot the grain size distribution on a gradation curve. For this example, the information is provided in the problem statement and a gradation curve is included.

Step 2. Determine the geotextile retention criterion

Use the decision tree in Figure 5.4 to assist in determining the appropriate soil retention criterion for the geotextile. The figure has been modified to include guidance when a granular transition layer (i.e., composite filter) is necessary. A composite filter is typically required when the base soil is greater than 30% clay having relatively low cohesion, or is predominantly fine-grained soil (more than 50% passing the #200 sieve). If a granular transition layer is required, the geotextile should be designed to be compatible with the properties of the granular layer.

Note: If the required AOS is smaller than that of available geotextiles, then a granular transition layer is required, even if the base soil is not clay. However, this requirement can be waived if the base soil exhibits the following conditions for hydraulic conductivity K , plasticity index PI, and undrained shear strength c :

$K_s < 1 \times 10^{-7}$ cm/s
PI > 15
c > 10 kPa

Under these soil conditions there is sufficient cohesion to prevent soil loss through the geotextile. A geotextile with an AOS less than a #70 sieve (approximately 0.2 mm) can be used with soils meeting these conditions, and essentially functions more as a separation layer than a filter.

Document the percentages of gravel, fines, and clay that were observed in the base soil sample. Gravel is characterized by particle sizes greater than 4.75 mm, fines are defined as the particles that passed the No. 200 sieve, and clay is characterized by particle sizes less than 0.005 mm per ASTM D422 (ref. 2). Also, document the plasticity index (PI) if the percentage of clay is greater than 20 percent and the median grain size d_{50} , d_{60} and d_{10} . Due to the inherent variability of natural soils, these parameters should be determined for a number of samples and a representative value, or range of values, should be used for design based on engineering judgment.. Worksheet 3 from Chapter 8 can be used for documenting the geotextile selection process. For this example, the sample contains no gravel, 71.9 percent fines, and 24.2 percent clay.

$d_{10} = 0.0017$ mm
 $d_{30} = 0.0074$ mm
 $d_{50} = 0.025$ mm
 $d_{60} = 0.04$ mm
 $K_s = 7.5 \times 10^{-7}$ cm/s
PI = 7%
Gravel: 0 %
Fines: 71.9%
Clay: 24.2%

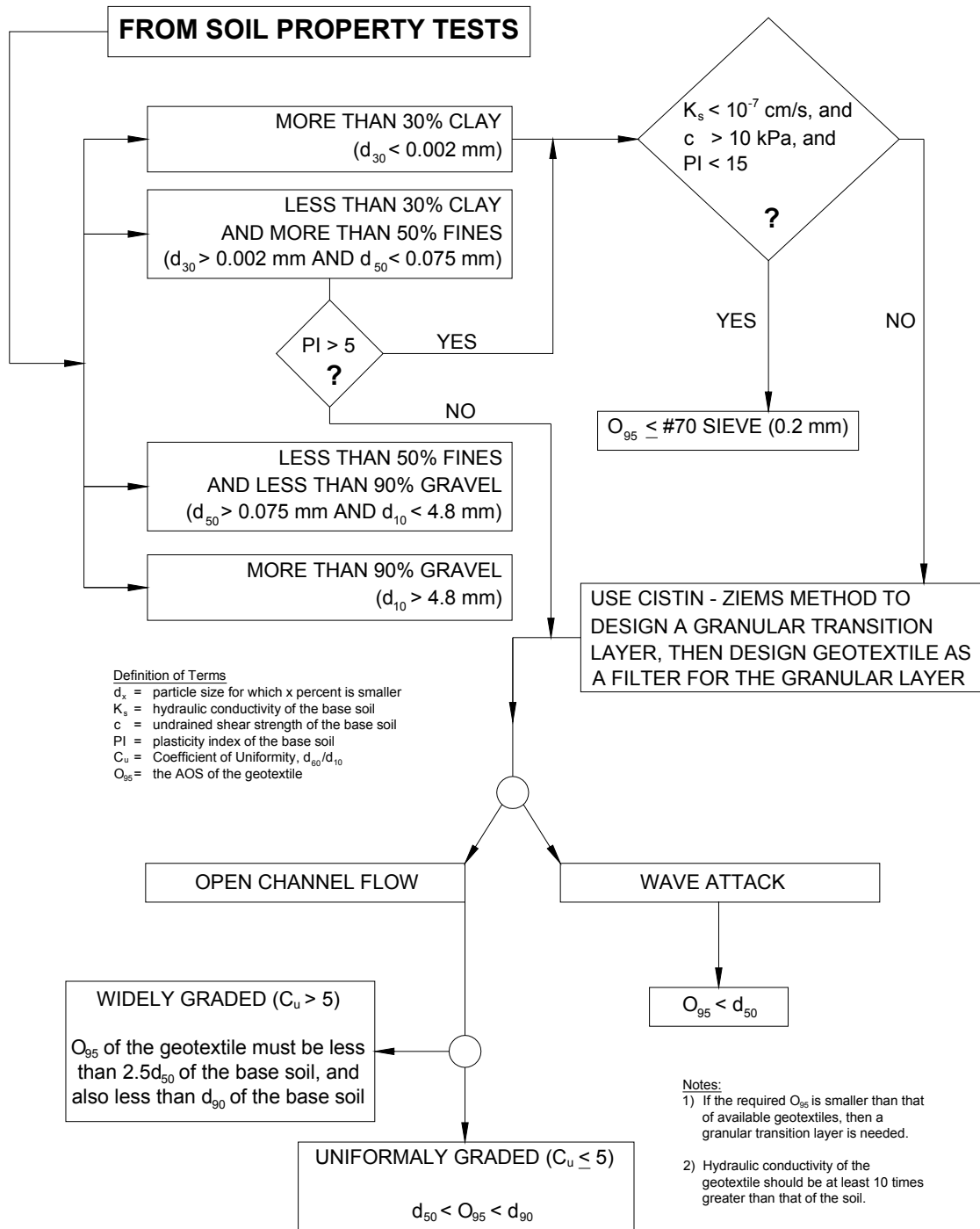

Figure 5.4—Geotextile selection based on soil retention (ref. 31)

From Figure 5.4, determine if a granular transition layer will be necessary. If a granular filter is used, the remaining steps in the geotextile selection should be based on the granular filter

properties. Go to Step 2b to design the granular filter before continuing on with geotextile selection.

From Figure 5.4, no wave attack is expected at Meandering River, therefore the Uniformity Coefficient of the granular filter will be used for the final step in determining the retention criteria. The Uniformity Coefficient, C_U , is defined as follows:

$$C_U = \frac{d_{60}}{d_{10}} \quad (\text{Eqn. 5.3})$$

where:

d_x = Particle size of which X percent is smaller

For this example,

$$C_U = d_{60}/d_{10} = 0.48 \text{ mm}/0.18 \text{ mm} = 2.7$$

Because C_U of the granular filter is smaller than 5, it is considered "uniformly graded."

Therefore,

$$d_{50} < O_{95} < d_{90}$$

The geotextile retention criterion is shown on Worksheet 3.

Step 2b. Determine the granular filter retention and permeability criteria, if needed

Determine Maximum Allowable d_{50f} for Filter. Enter the Cistin - Ziems design chart (Figure 5.5) with the Coefficient of Uniformity for the base soil on the x-axis. Find the curve that corresponds to the Coefficient of Uniformity for the filter in the body of the chart, and from that point determine the maximum allowable A_{50} from the y-axis. Compute the maximum allowable d_{50f} of the filter using $d_{50f(\text{max})} = A_{50\text{max}}$ times d_{50s} . Check to see if the candidate filter material conforms to this requirement. If it does not, continue checking alternate candidates until a suitable material is identified.

Enter the Cisten – Ziems chart (Figure 5.5) with $C_U = 23.53$ of the native soil on the x-axis (in this case data have been extrapolated). Chart vertically up to a location corresponding to a C_U of 2.7 for the candidate filter. Read a maximum allowable value A_{50} of approximately 8.5 on the y-axis.

$$\text{Max. allowable } d_{50f} = A_{50}(d_{50s}) = 8.5 \times 0.025 = 0.213 \text{ mm}$$

Because the granular filter has a d_{50} greater than this value ($d_{50f} = 0.42 \text{ mm} > 0.213 \text{ max. allowable}$), a second (coarser) granular filter layer could be designed and placed on top of the first filter layer or alternatively, a geotextile filter may be considered.

The gradation curve of the granular transition layer does not necessarily need to be approximately parallel to the base soil curve. At this point the granular transition layer design, when required, is complete. For practical considerations related to constructability and inspection, the granular filter thickness should not be less than 6 inches (152 mm). For placement under water, thickness should be increased by 50 percent.

For this example, a granular filter is required and should be 9 inches (229 mm) thick because the revetment will be continuously under water. The particle size gradation of the selected

pit run sand is provided in Table 5.4 and is plotted on Worksheet 2. Notice that the gradation of the pit run sand is approximately parallel to that of the base soil for this example. Calculations for the granular filter are presented on Worksheet 3.

Sieve Size	Particle Size (mm)	Percent Finer
3/8 in.	9.52	100
No. 4	4.75	98.7
No. 8	2.36	95.5
No. 16	1.18	89.3
No. 30	0.600	71.8
No. 50	0.300	26.0
No. 100	0.150	5.0
No. 200	0.075	4.1

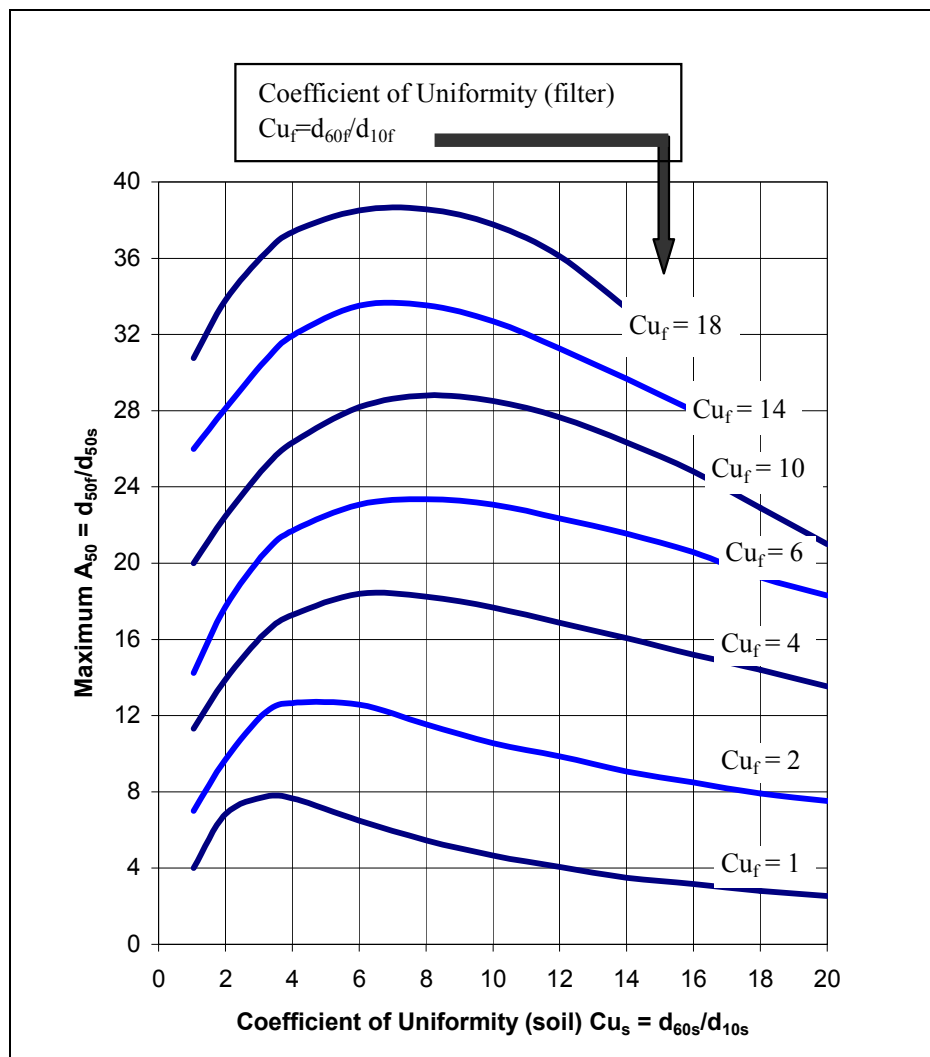

Figure 5.5—Granular filter design chart according to Cistin and Ziems (Ref. 31)

Step 3. Determine the geotextile permeability criterion

The permeability criterion is specified as a function of the base soil permeability as follows:

$$K_g \geq 10K_s \quad (\text{Eqn. 5.4})$$

where:

$$\begin{aligned} K_g &= \text{Permeability of the geotextile, cm/s} \\ K_s &= \text{Permeability of the base soil or granular filter, cm/s} \end{aligned}$$

To obtain the permeability of a geotextile in cm/s, multiply the thickness of the geotextile in cm by its permittivity in s^{-1} . Typically, the designer will need to contact the geotextile manufacturer to obtain values of permittivity.

Generally speaking, if the permeability of the base soil or granular filter has been determined from laboratory testing, that value should be used. If testing was not conducted, then the Fair-Hatch Equation should be used. For this example, the calculation of permeability of the granular filter using the Fair-Hatch Equation is shown below. A dry unit weight of 115 lb/ft³ and 95 percent compaction are assumed for the selected pit run sand filter material.

Calculate the porosity:

$$\phi = 1 - \frac{C}{100} \cdot \frac{\gamma_d}{165.4} \quad (\text{see Eqn. 5.2})$$

$$\phi = 1 - \frac{95}{100} \cdot \frac{115.0}{165.4} = 0.339$$

Calculate the permeability for the pit run sand. For the gradation in Table 5.4 there will be eight particle size intervals, the seven shown in the table plus one to extrapolate down to 0 percent (particle size 0.008 mm scaled from Worksheet 2).

$$K_s = 1.958 \times 10^6 \frac{\phi^3}{(1-\phi)^2} \left(\frac{1}{49 \left(\sum_{n=1}^N \frac{P_n}{d_n} \right)^2} \right) \quad (\text{see Eqn. 5.1})$$

$$\begin{aligned} \sum_{n=1}^8 \frac{P_n}{d_n} &= \frac{100 - 98.7}{\sqrt{(9.52)(4.75)}} + \frac{98.7 - 95.5}{\sqrt{(4.75)(2.36)}} + \frac{95.5 - 89.3}{\sqrt{(2.36)(1.18)}} + \frac{89.3 - 71.8}{\sqrt{(1.18)(0.600)}} + \frac{71.8 - 26.0}{\sqrt{(0.600)(0.300)}} + \\ &\frac{26.0 - 5.0}{\sqrt{(0.300)(0.150)}} + \frac{5.0 - 4.1}{\sqrt{(0.150)(0.075)}} + \frac{4.1 - 0}{\sqrt{(0.075)(0.008)}} = 408.476 \text{ mm}^{-1} \end{aligned}$$

$$K_s = 1.958 \times 10^6 \frac{0.339^3}{(1 - 0.339)^2} \left(\frac{1}{49(408.476)^2} \right) = 0.02 \text{ cm/s}$$

The permeability for the granular filter and the calculated criterion for the geotextile are indicated on Worksheet 3.

Step 4. Select potential geotextiles for design

Using results obtained in Steps 2 and 3 select several geotextile candidates. A valuable reference is the annual "Geotechnical Fabrics Report - Specifier's Guide", published by the Industrial Fabrics Association International (ref. 27).

For this example, three products from three different manufacturers are selected as candidates for design. The selected systems are 121F, 113-004, and XW45. All three products satisfy the retention and permeability criteria.

Step 5. Screen potential geotextiles using the following considerations

1. Geotextile strength relating to installation. This refers to the ability of the geotextile to withstand damage during installation, the weight of the block system, and additional compaction. Minimum strength requirements for geotextile should be in accordance with AASHTO M-288 specification as outlined in ASTM D6684 (ref. 16):

		Class 1		Class 2		Class 3		
Property	ASTM Test Methods	Units	Elongation <50% ^A	Elongation >50% ^A	Elongation <50% ^A	Elongation >50% ^A	Elongation >50% ^A	Elongation >50% ^A
Grab Strength	D4632	lb	315	200	250	160	180	110
Sewn Seam Strength ^B	D4632	lb	270	180	220	140	160	100
Tear Strength	D4533	lb	110	80	90 ^C	55	70	40
Puncture Strength	D4833	lb	110	80	90	55	70	40

^A Percent elongation as measured in accordance with ASTM D4632 (ref. 10).

^B Seam strength determined in accordance with ASTM D4632 when seams are required.

^C Woven monofilament geotextiles should have a required Minimum Average Roll Value (MARV) of not less than 55 lb (25 kg).

Note:

Class 1 recommended for harsh or severe installation conditions where there is a greater potential for geotextile damage, including irregular sections where repeated mattress lifting, realignment, and replacing is expected, or when vehicular traffic on the installation is anticipated.

Class 2 recommended for installation conditions where mattress placement in regular, even reaches is expected and little or no vehicular traffic on the installation will occur, or when hand-placing on a graded surface of native soils.

Class 3 specified for the least severe installation environments, typically hand-placed systems (zero drop height) on a bedding layer of graded sand, road base aggregate, or other select imported material.

2. Durability and the ability to withstand long-term degradation. This is particularly a concern for geotextiles exposed to ultraviolet light during installation. Follow manufacturer recommendations for protection against ultraviolet light degradation. For additional guidelines regarding the selection of durability test methods refer to ASTM D5819, "Standard Guide for Selecting Test Methods for Experimental Evaluation of Geosynthetic Durability" (ref. 15).
3. Minimize Long-Term Clogging Potential. When a woven geotextile is used, its percent open area (POA) should be greater than, or equal to, 4% by area ($POA \geq 4\%$). Woven slit film geotextiles are not recommended for use under ACB systems. If a non-woven geotextile is used, its porosity should be greater than, or equal to, 30% by volume. A good rule of thumb suggests that the geotextile having the largest AOS that satisfies the particle retention criteria should be used (provided of course that all other minimum allowable values described in this section are met as well).

For this example, the application is assumed to satisfy the condition for a Class 3 geotextile, least severe installation environments, typically hand-placed systems (zero drop height) on a bedding layer of graded sand, road base aggregate, or other select imported material.

Step 6. Make a final geotextile selection by assessing compliance with permeability, retention and durability requirements.

The XW45 system from Geotextile Fabrics, Inc. is selected because it satisfies the material and design requirements necessary for the assumed design conditions.

Note: During construction, but before the geotextile is placed, collect soil samples for analysis to ensure that the geotextile selected in the design process is still appropriate, See Chapter 7 for required testing frequency and laboratory tests.

Worksheet 2—Grain Size Distribution Curve

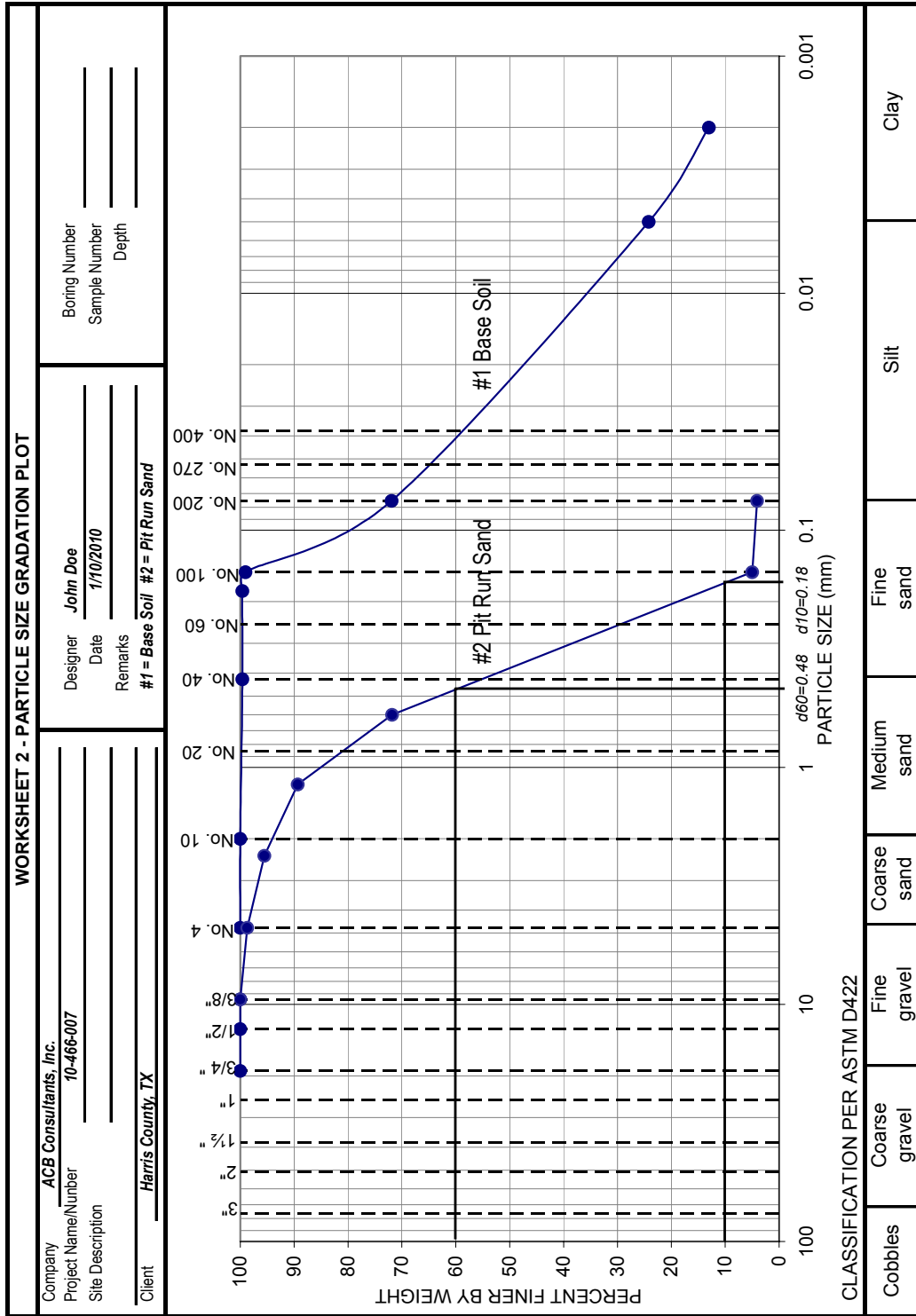

Worksheet 3—Geotextile Selection and Granular Filter Design

Project Information

Site Description: Meandering River

Company: ACB Consultants, Inc.

Soil Information

Designer: John Doe Date: 1/10/10

Description: Reddish Brown Clayey Silt

Project Name/Number: 10-466-007

Percent
Gravel: 0 Fines: 71.9 Clay: 24.2

Client: Harris County, TX

Plasticity Index: 7

From Figure 5.4 – Geotextile Criterion Based on

Base Soil Properties Granular Filter Properties

For Granular Filter Only from Figure 5.5

$d_{10 \text{ BASE}}$ (mm): 0.0017

$d_{10 \text{ FILTER}}$ (mm): 0.18

$d_{50 \text{ BASE}}$ (mm): 0.0025

$d_{50 \text{ FILTER}}$ (mm): 0.42

$d_{60 \text{ BASE}}$ (mm): 0.04

$d_{60 \text{ FILTER}}$ (mm): 0.48

$$C_{U \text{ BASE}} = \frac{d_{60}}{d_{10}} = \frac{0.04}{0.0017} = 23.53$$

$$C_{U \text{ FILTER}} = \frac{0.48}{0.18} = 2.7$$

Max. all. $d_{50 \text{ FILTER}}$:

$$A_{50} \times d_{50 \text{ BASE}} = 8.5 \times 0.0025 = 0.213$$

Description of Selected Material: Pit Run Sand

Geotextile Retention Criterion from Figure 5.4

Base Soil or Granular Filter Particle Sizes

$$C_U = \frac{d_{60}}{d_{10}} = \frac{0.48}{0.18} = 2.7$$

d_{10} (mm): 0.18

currents are

d_{50} (mm): 0.41

mild severe

d_{60} (mm): 0.48

geotextile retention criteria for O_{95}

d_{90} (mm): 1.2

$$0.41 \text{ mm} < O_{95} < 1.2 \text{ mm}$$

Geotextile Permeability Criterion

Soil permeability determined from

Fair-Hatch Equation laboratory testing of soil

Other Explain _____

K_s (cm/s): 0.02 geotextile permeability criterion: $K_g \geq 10K_s \geq 0.20$ cm/s

Worksheet 3 Continued – Geotextile Selection and Granular Filter Design

Geotextile Strength Screening Table

Geotextile Strength Properties (Class 3 per AASHTO M-288)	Selected Woven Geotextile Products					
	<i>121F</i>		<i>113-004</i>		<i>XW45</i>	
	Value	Satisfactory?	Value	Satisfactory?	Value	Satisfactory?
Grab Strength (lb) $\geq 180^A$	<i>81</i>	<i>No</i>	<i>200</i>	<i>Yes</i>	<i>310</i>	<i>Yes</i>
Elongation (%)	<i>45</i>	<i>Yes</i>	<i>15</i>	<i>Yes</i>	<i>30</i>	<i>Yes</i>
Puncture Strength (lb) $\geq 70^A$	<i>43</i>	<i>Yes</i>	<i>120</i>	<i>Yes</i>	<i>155</i>	<i>Yes</i>
Trapezoidal Tear Strength (lb) $\geq 70^A$	<i>34</i>	<i>Yes</i>	<i>65</i>	<i>Yes</i>	<i>85</i>	<i>Yes</i>

^A Grab strength, Puncture Strength and Trapezoidal Tear Strength minimum values based on requirements for Class 3 geotextile with less than 50% elongation (ASTM D6684 – Table 2).

Note: use additional tables if more than three products are being evaluated

Manufacturer/Selected Geotextile

Geotextile Fabrics, Inc./XW45

Type of geotextile structure:	<input checked="" type="checkbox"/> <i>Woven</i>	<input type="checkbox"/> <i>Non -Woven</i>
O ₉₅ (mm):	<u><i>0.60</i></u>	<u> </u>
K _g (cm/s):	<u><i>0.40</i></u>	<u> </u>
Percent Open Area $\geq 4\%$:	<u><i>4</i></u>	<u><i>N/A</i></u>
Porosity $\geq 30\%$:	<u><i>N/A</i></u>	<u> </u>
Mass per unit Area $\geq 400\text{g/m}^2$ (12 oz/yd ²):	<u><i>N/A</i></u>	<u> </u>

6.0 MANUFACTURE REQUIREMENTS FOR ACB SYSTEMS

ASTM D6684, “Standard Specification for Materials and Manufacture of Articulating Concrete Block (ACB) Revetment Systems” (ref 16), provides specifications for structural components, material composition and physical properties of ACB systems that are essential to long term durability and structural performance. The standard specifies an average minimum compressive strength of three units no less than 4,000 psi (27.58 MPa), with no individual unit less than 3,500 psi (24.13 MPa). The maximum water absorption is 9.1 lb/ft³ (145.8 kg/m³) (average of three units) and no individual unit more than 11.7 lb/ft³ (187.4 kg/m³). The standard further requires an average minimum density of three units of 130 lb/ft³ (2082.4 kg/m³) and no individual unit less than 125 lb/ft³ (2002.3 kg/m³).

The standard further requires cables and fittings, which facilitate lifting and placing of large mattresses, to demonstrate a minimum factor of safety of 5.0 with respect to lifting. This applies to cable or rope, splice fittings, sleeves, and stops. Geotextile filters must meet minimum standards for grab strength, sewn seam strength, tear strength and puncture strength. Geotextile must also satisfy subsoil compatibility assessment as detailed in Chapter 5, Geotextile and Granular Filter Design.

7.0 INSTALLATION GUIDELINES

The proper installation of an ACB revetment system is essential to achieve suitable hydraulic performance and maintain stability against the erosive force of flowing water during the design hydrologic event. These guidelines are intended to maximize the conformity between the design intent and the actual field-finished conditions of the project. Quality workmanship is important to the ultimate performance of the system. The following sections address the subgrade preparation, geotextile placement, block system placement, backfilling and finishing, and inspection. These guidelines apply to the installation of ACB revetment systems, whether hand-placed or placed as a mattress, in compliance with ASTM D6884, "Standard of Practice for the Installation of Articulating Concrete Block (ACB) Revetment Systems" (ref. 17).

These guidelines do not purport to address the safety issues associated with installation of ACB revetment systems, including use of hazardous materials, mechanical equipment, and operations. It is the responsibility of the contractor to establish and adopt appropriate safety and health practices. Also, the contractor is obligated to comply with prevalent regulatory codes, such as OSHA (Occupational Health and Safety Administration) regulations, while using these guidelines.

At the completion of rough grading, soil samples representative of subgrade conditions shall be obtained at a minimum frequency of one sample per 50,000 blocks, or additional fraction thereof, and tested for the following properties:

1. Grain size distribution (ASTM D422)
2. Atterberg Limits (ASTM D4318)
3. Standard Proctor Density (ASTM D698)

Results of laboratory tests shall be submitted to the engineer to ensure conformance with design parameters prior to placement of the geotextile and ACB revetment system. When a granular filter is used, it shall be tested for grain size distribution at the same frequency as the subgrade soil testing.

7.1 Subgrade Preparation

Stable and compacted subgrade soil should be prepared to the lines, grades, and cross sections shown on the contract drawings. Termination trenches and transitions between slopes and embankment crests, benches, berms, and toes should be compacted, shaped and uniformly graded to facilitate the development of intimate contact between the ACB revetment system and the underlying grade. Secure the revetment in a manner that prevents soil migration when the ACB matrix is terminated at a structure, such as a concrete slab or wall.

Subgrade soil should be approved by the engineer to confirm that the actual subgrade soil conditions meet the required material and compaction standards. Soils not meeting the required standards should be removed and replaced with acceptable material.

Care should be exercised so as not to excavate below the grades shown on the contract drawings, unless directed by the engineer to remove unsatisfactory materials and any excessive excavation should be filled with compacted backfill material as approved by the engineer. Where it is impractical, in the opinion of the engineer, to dewater the area to be filled, over-excavations should be backfilled with crushed rock or stone conforming to the grading and quality requirements of well-graded coarse aggregate in ASTM C33 "Standard Specification for Concrete Aggregates" (ref. 1), or as directed by the engineer.

When placing dry areas to receive the ACB system, the surface should be graded smooth to ensure that intimate contact is achieved between the subgrade surface and the geotextile and between the geotextile and the bottom surface of the ACB revetment system. Unsatisfactory soils, soils too wet to achieve desired compaction, and soils containing roots, sod, brush, or other organic materials, should be removed and replaced with an approved material, and compacted. The subgrade should be uniformly compacted to a minimum 90 percent of the Standard Proctor density in accordance with ASTM D698 (ref. 3) or as required by the project specification, whichever is more stringent. Should the subgrade surface for any reason become rough, eroded, corrugated, uneven, textured, or traffic marked prior to ACB installation, such unsatisfactory portion should be scarified, reworked, recompacted, or replaced as directed by the engineer.

Excavation of the subgrade, above the water line, should not be more than 2 inches (51 mm) below the grade indicated on the contract drawings. Excavation of the subgrade below the water line should not be more than 4 inches (102 mm) below the grade indicated on the contract drawings.

Where such areas are below the allowable grades, they should be brought to grade by placing approved material and compacting in lifts not exceeding 6 inches (152 mm) in thickness. Where such areas are above the allowable grades they should be brought to grade by removing material, or reworking existing material, and compacting as directed by the engineer. The subgrade should be raked, screeded, or rolled by hand or machine to achieve a smooth compacted surface that is free of loose material, clods, rocks, roots, or other materials that would prevent satisfactory contact between the geotextile and the subgrade. Immediately prior to placing the geotextile and ACB system, the prepared subgrade should be inspected and approved by the engineer.

7.2 Placement of Geotextile

The geotextile should be placed directly on the prepared area, in intimate contact with the subgrade, and free of folds or wrinkles. The geotextile shall be placed in such a manner that placement of the overlying materials will not excessively stretch or tear the geotextile. After geotextile placement, the work area should not be disturbed so as to result in a loss of intimate contact between the articulating concrete block and the geotextile, or between the geotextile and the subgrade. The geotextile should not be left exposed longer than the manufacturer's recommendation to minimize damage due to exposure to ultraviolet radiation.

The geotextile should be placed so that the upstream strips of fabric overlap downstream strips and so that upslope strips overlap down slope strips. Overlaps should be in the direction of flow wherever possible. The joints should be overlapped a minimum 3 ft (1 m) for below-water installations and a minimum 1.5 feet (0.5 m) for dry installations in accordance with ASTM D6884 (ref. 16). When a sewn seam is used for geotextile seaming, the thread should consist of high strength, U.V. resistant polypropylene or polyester.

When a granular filter transition layer is used, the geotextile should be placed so as to encapsulate the granular filter material as shown in Figure 7.1. The distance between encapsulation points should not exceed 20 feet (6 m). The geotextile should extend to the edge of the revetment within the top, toe, and side termination points of the revetment. If necessary to expedite construction and to maintain the recommended overlaps, anchoring pins or 11 gauge (3 mm), 6- by 1-inch (152 by 25 mm) U-staples may be used; however, weights (e.g., sand filled bags) are preferred to prevent creating holes in the geotextile.

7.3 Placement of ACB System

The articulating concrete block system should be placed on the geotextile in such a manner as to produce a smooth plane surface in intimate contact with the geotextile. For blocks within the mat and blocks that are hand set, the joint spacing between adjacent blocks is to be maintained so that binding of blocks does not occur and block-to-block interlock is achieved. In curvature and grade change areas, alignment of the individual block and the orientation of the neighboring adjacent block is to provide for intimate block to fabric contact and block-to-block interlock. Care shall be taken during block installation so as to avoid damage to the geotextile or subgrade during the installation process. Preferably, when a geotextile is used, the ACB system placement should begin at the upstream end and proceed downstream. If an ACB system is to be installed from downstream up, a contractor option is to place a temporary toe on the front edge of the ACB system to protect against undermining when flows are anticipated. On sloped sections, where practical, placement shall begin at the toe of the slope and proceed up the slope. Block placement shall not bring block-to-block interconnections into tension. Individual blocks within the plane of the finished system shall not exceed the protrusion tolerance beyond that used in the stability design of the system. The typical protrusion tolerance is 0.5 inches (13 mm).

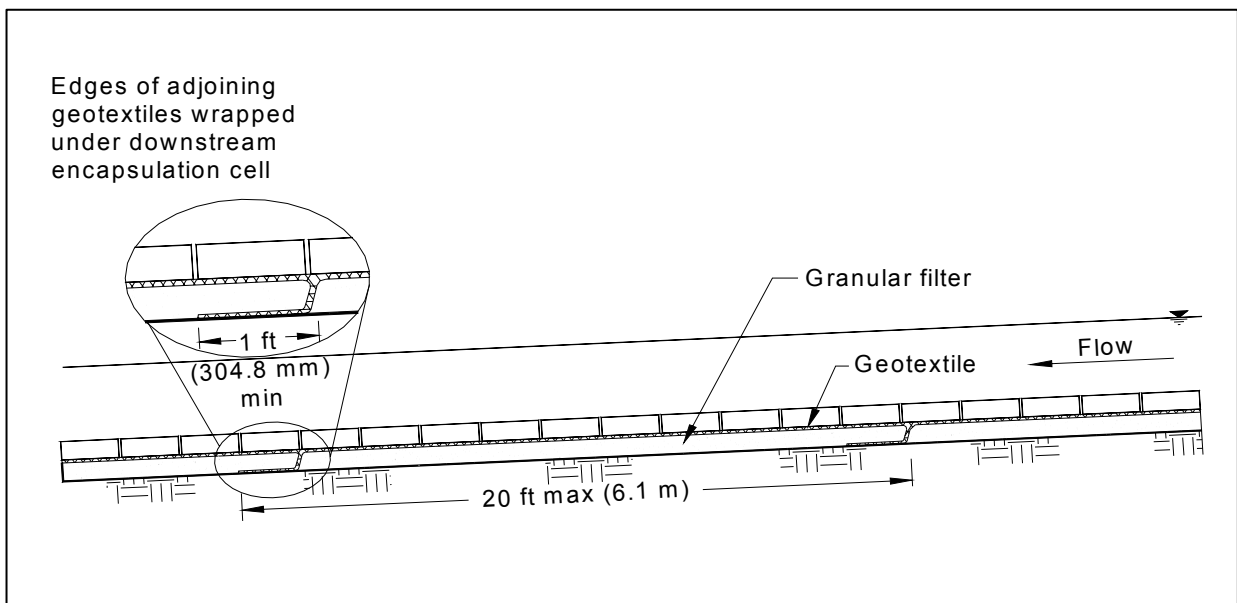

Figure 7.1—Granular filter detail showing granular filter encapsulation.

Do not use the ACB revetment system as a road for heavy construction traffic unless designed as a flexible pavement that can handle the expected wheel loads. Light traffic, such as single axle trucks and mowing equipment, may operate on installed ACB systems.

If assembled and placed as large mattresses, the articulating mats can be attached to a spreader bar to aid in the lifting and placing of the mats in their proper position with a crane. Figure 7.2 contains a photo of a crane placing bank protection with a spreader bar while Figure 7.3 is a close-up of an ACB mat and spreader bar. The mats should be placed side by side and/or end to end so the mats abut each other.

Mat seams or openings between mats creating voids or separations greater than 2 inches (51 mm) between blocks in the matrix should be filled with grout. Whether placed by hand or in large mattresses, distinct grade changes should be accommodated with a well-rounded transition (i.e., minimum radius determined by individual system characteristics). Figure 7.4 is a conceptual detail showing a minimum radius for a top and toe-of-slope transition for bed and bank protection. The trapezoidal channel in Figure 7.5 shows a properly finished ACB revetment system with minimum radius-of-curvature. A top-of-slope transition and a typical toe detail for bank protection is shown in Figure 7.6. Figure 7.7 is a conceptual detail for spillways or embankment overtopping flow and Figure 7.8 is a photo of an ACB system that has been installed to protect an embankment during overtopping flow.



Figure 7.2—ACB mats being placed with a crane and spreader bar.



Figure 7.3—Close-up of spreader bar and ACB mat.

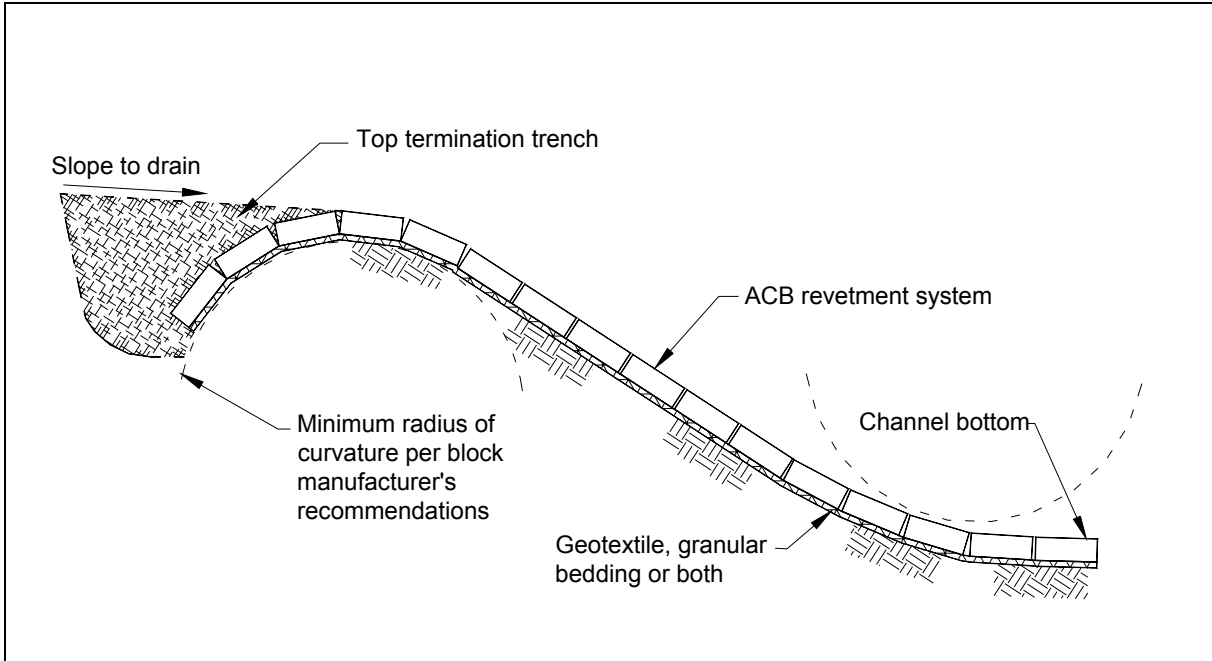

Figure 7.4—Conceptual detail of minimum radius-of-curvature for bed and bank protection.



Figure 7.5—Bed and bank protection with minimum radius-of-curvature at grade changes and top-of-slope termination points.

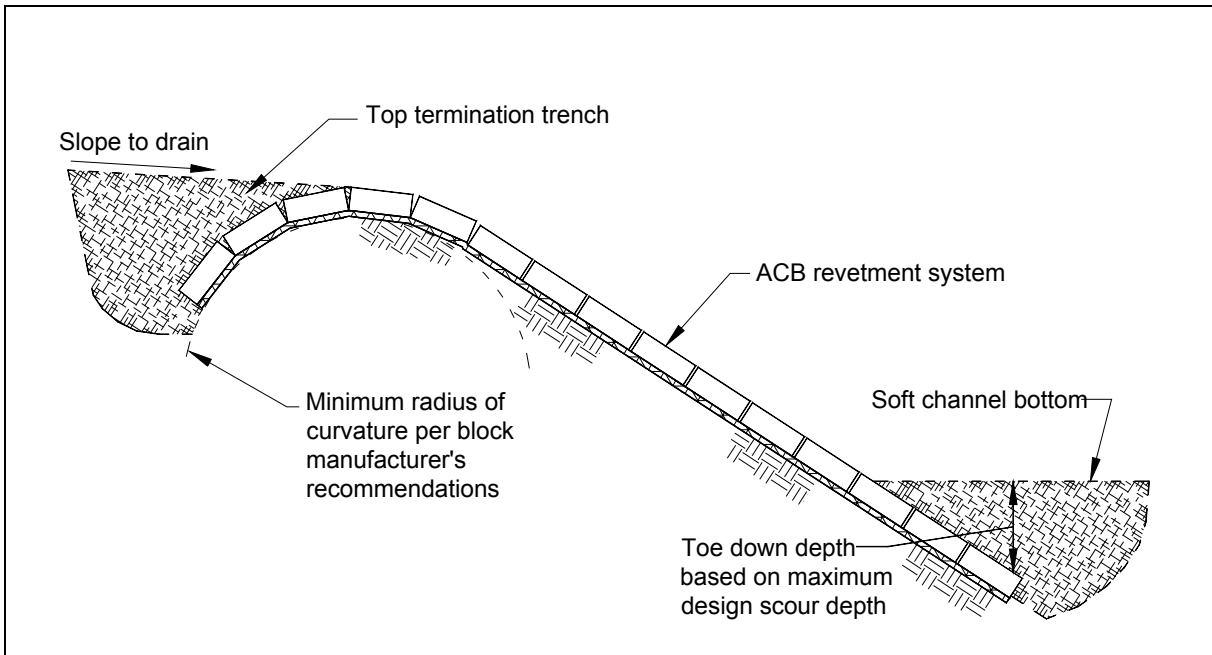

Figure 7.6—Conceptual detail of minimum radius-of-curvature for bank protection

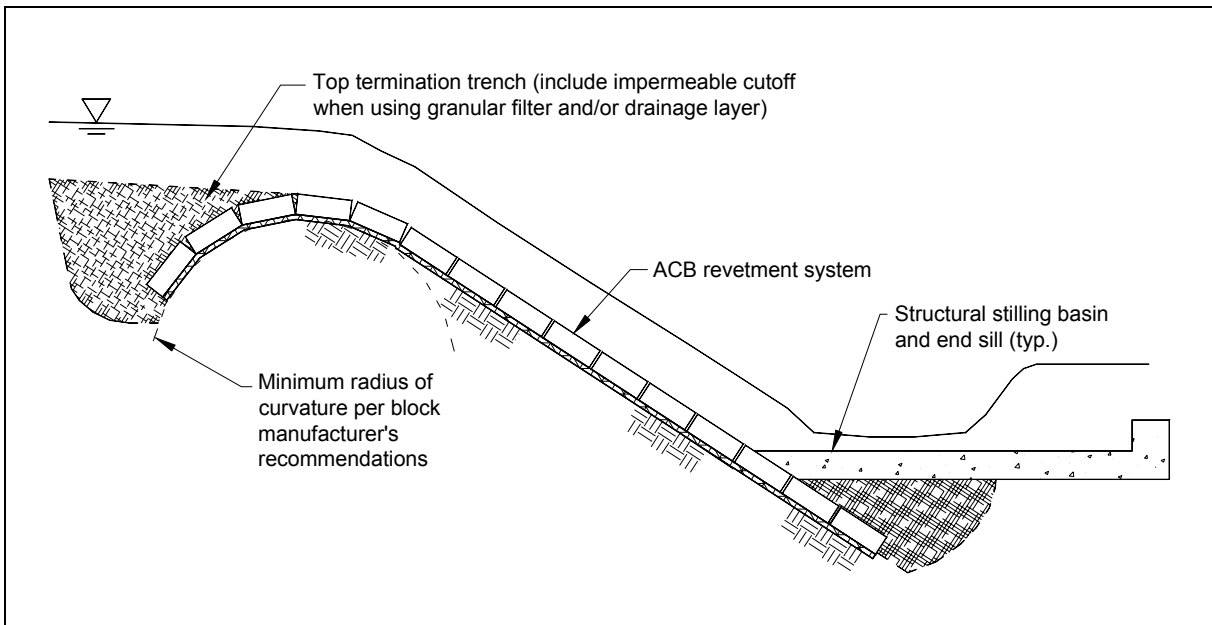

Figure 7.7—Conceptual detail of toe termination for spillways or embankment overtopping flow



Figure 7.8—Embankment dam overtopping protection with radius-of-curvature at top-of-slope termination

If a discontinuous revetment surface exists in the direction of flow, a grout seam at the grade change location should be provided to produce a continuous, flush finished surface. Grout seams should not be wider than one-half the maximum dimension of a single block.

Termination trenches should be backfilled with approved fill material and compacted flush with the top of the blocks. The integrity of a soil trench backfill must be maintained so as to ensure a surface that is flush with the top surface of the articulating blocks for its entire service life. Top, toe, and side termination trenches should be backfilled with suitable fill material and compacted immediately after the block system has been placed.

Anchors or other penetrations through the geotextile should be grouted or otherwise repaired in a permanent fashion to prevent migration of subsoil through the penetration point.

7.4 Finishing

The open area of the articulating concrete block system is typically either backfilled with suitable soil for revegetation or with 3/8- to 3/4-inch (9.5 to 19 mm) diameter uniform crushed stone or a mixture thereof. Crushed stone can enhance the interlock restraint, but can make the ACB revetment system less flexible. Backfilling with soil or granular fill within the cells of the system should be completed as soon as possible after the revetment has been installed. When topsoil is used as a fill material above the normal waterline, overfilling by 1 to 2 inches (25 to 51 mm) may be desirable to allow for consolidation.

7.5 Inspection

Each step of installation, including subgrade preparation, geotextile and granular filter placement, ACB revetment placement, and the overall finished condition, including termination points, should be inspected and approved by the Engineer.

8.0 WORKSHEETS

Subsequent pages in this section provide design worksheets. The worksheets are provided as a design aid given the complexity of some of the calculations necessary for ACB system design. They are intended to guide the designer through the appropriate series of calculations and decisions and to expedite the review process of the reviewing agency. It is the responsibility of the designer to contact manufacturers and investigate alternative products and ACB systems appropriate to each specific application.

Worksheet 1A—ACB Design and Selection – Customary U.S. Units

Project Information

Company: _____
 Designer: _____ Date: _____
 Project Name/Number: _____
 Client: _____
 Target Factor of Safety: _____

Additional Comments

Site Information

Description: _____
 Bed Slope (ft/ft): _____ (degrees): _____
 Side Slope (H/V): _____ (degrees): _____
Hydraulic Design Data
 Discharge (cfs): _____ Description: _____
 Velocity (ft/s): _____ Flow Depth (ft): _____
 Friction Slope (ft/ft): _____
 Design Shear Stress (lb/ft²): _____

Variables in SF Calculation	ACB Systems for SF Calculation					
Tested bed slope (degrees)						
Max. tested velocity (ft/s)						
W (lb)						
W _s (lb)						
b (ft)						
ℓ ₁ (ft)						
ℓ ₂ & ℓ ₄ (ft)						
ℓ ₃ (ft)						
τ _C (lb/ft ²)						
η ₀						
ΔZ (ft)						
F' _L & F' _D (lb)						
a _θ						
θ (degrees)						
β (degrees)						
η ₁						
δ (degrees)						
SF						
Bed Slope: Tested ≥ Application??						
Velocity: Max tested ≥ Design??						

Manufacturer/Selected ACB System

Critical Shear Stress (lb/ft²): _____
 Calculated Factor of Safety: _____
 Block Weight (lb): _____

Block Width (in.): _____
 Block Length (in.): _____
 Block Height (in.): _____
 Acceptable Protrusion (in.): _____

Worksheet 1B—ACB Design and Selection – SI Units

Project Information

Company: _____
 Designer: _____ Date: _____
 Project Name/Number: _____
 Client: _____
 Target Factor of Safety: _____

Additional Comments

Site Information

Description: _____
 Bed Slope (m/m): _____ (degrees): _____
 Side Slope (H/V): _____ (degrees): _____

Hydraulic Design Data

Discharge (cms): _____ Description: _____
 Velocity (m/s): _____ Flow Depth (m): _____
 Friction Slope (m/m): _____
 Design Shear Stress (Pa): _____

Variables in SF Calculation	ACB Systems for SF Calculation					
Tested bed slope (degrees)						
Max. tested velocity (m/s)						
W (N)						
W_S (N)						
b (m)						
l_1 (m)						
l_2 & l_4 (m)						
l_3 (m)						
τ_c (Pa)						
η_0						
ΔZ (m)						
F'_L & F'_D (N)						
a_0						
θ (degrees)						
β (degrees)						
η_1						
δ (degrees)						
SF						
Bed Slope: Tested \geq Application??						
Velocity: Max tested \geq Design??						

Manufacturer/Selected ACB System

Critical Shear Stress (Pa): _____
 Calculated Factor of Safety: _____
 Block Weight (N): _____

Block Width (mm): _____
 Block Length (mm): _____
 Block Height (mm): _____
 Acceptable Protrusion (mm): _____

Worksheet 2—Grain Size Distribution Curve

WORKSHEET 2 - PARTICLE SIZE GRADATION PLOT			
Company _____ Project Name/Number _____ Site Description _____ Client _____	Designer _____ Date _____ Remarks _____	Boring Number _____ Sample Number _____ Depth _____	
CLASSIFICATION PER ASTM D422 Cobble Coarse gravel Fine gravel Coarse sand Medium sand Fine sand Silt Clay			

Worksheet 3—Geotextile Selection and Granular Filter Design

Project Information

Site Description: _____

Company: _____

Soil Information

Designer: _____ Date: _____

Description: _____

Project Name/Number: _____

Percent Gravel: _____ Fines: _____ Clay: _____

Client: _____

Plasticity Index: _____

From Figure 5.4 – Geotextile Criterion Based on

Base Soil Properties Granular Filter Properties

For Granular Filter Only from Figure 5.5

d₁₀ BASE (mm): _____

d₁₀ FILTER (mm): _____

d₅₀ BASE (mm): _____

d₅₀ FILTER (mm): _____

d₆₀ BASE (mm): _____

d₆₀ FILTER (mm): _____

$$C_{U \text{ BASE}} = \frac{d_{60}}{d_{10}} = \frac{\quad}{\quad} = \quad$$

$$C_{U \text{ FILTER}} = \frac{\quad}{\quad} = \quad$$

Max. all. d₅₀ FILTER:
 $A_{50} \times d_{50 \text{ BASE}} = \quad \times \quad = \quad$

Description of Selected Material: Pit Run Sand

Geotextile Retention Criterion from Figure 5.4

Base Soil or Granular Filter Particle Sizes

$$C_U = \frac{d_{60}}{d_{10}} = \frac{\quad}{\quad} = \quad$$

d₁₀ (mm): _____

currents are

d₅₀ (mm): _____

mild severe

d₆₀ (mm): _____

geotextile retention criteria for O₉₅

d₉₀ (mm): _____

Geotextile Permeability Criterion

Soil permeability determined from

Fair-Hatch Equation laboratory testing of soil

Other Explain _____

K_s (cm/s): _____ geotextile permeability criterion: K_g ≥ 10K_s ≥ _____ cm/s

Worksheet 3 Continued – Geotextile Selection and Granular Filter Design

Geotextile Strength Screening Table

Geotextile Strength Properties	Selected Woven Geotextile Products					
	Value	Satisfactory?	Value	Satisfactory?	Value	Satisfactory?
Grab Strength (lb) \geq _____ ^A						
Elongation (%)						
Puncture Strength (lb) \geq _____ ^A						
Trapezoidal Tear Strength (lb) \geq _____ ^A						

Note: use additional tables if more than three products are being evaluated

^A Input appropriate strength values based on intended class of geotextile materials as specified in ASTM D6684, Table 2.

Manufacturer/Selected Geotextile

Geotextile Fabrics, Inc./XW45

Type of geotextile structure:

Woven

Non -Woven

O₉₅ (mm):

K_g (cm/s):

Percent Open Area \geq 4%:

N/A

Porosity \geq 30%:

N/A

Mass per unit Area

\geq 400g/m² (12 oz/yd²)

N/A

Worksheet 4 – ACB Design Properties and Testing Information

Manufacturer:						
Contact Person:					Date:	
Phone:			Fax:			
Address:						
Other Information:						
Block Group	Block Size/Designation					
Physical Properties						
Block Dimensions						
Moment Arm 1 (in.)						
Moment Arm 2 (in.)						
Moment Arm 3 (in.)						
Moment Arm 4 (in.)						
Percent Open Area						
Block Weight in Water (lb)						
Block Manning's n						
Performance Properties						
Critical Shear Stress (lb/ft ²) at Horizontal						
Peak Tested Velocity (ft/s)						
Tested Bed Slope (%)						
Tested/Extrapolated Data? (T/E)						
Tested with Drainage Layer? (Y/N)						

$$\text{Block Weight in Water} = \text{Block Weight} \cdot \left(\frac{\text{Specific Gravity Concrete} - 1}{\text{Specific Gravity Concrete}} \right)$$

$$\text{Moment Arm 1} = 0.5 \cdot (\text{Block Height})$$

$$\text{Moment Arm 2} = \text{Moment Arm 4} = 0.5 \cdot \sqrt{(\text{Block Width})^2 + (\text{Block Length})^2}$$

$$\text{Moment Arm 3} = 0.8 \cdot (\text{Block Height})$$

9.0 ANNOTATED BIBLIOGRAPHY

Hydraulics	ACB Design	Filtration	Reference
			<p>American Society for Testing and Materials (ASTM). Standard specifications, standard test methods, standard classifications, and standard guides.</p> <p>The following are the ASTM standards that are referenced in this manual and others that are related to ACB design, filter design, and system installation:</p> <ol style="list-style-type: none"> 1. C33-08 <i>Standard Specification for Concrete Aggregates</i> 2. D422-63(2007) <i>Standard Test Method for Particle-Size Analysis of Soils</i> 3. D698-07e1 <i>Standard Test Methods for Laboratory Compaction Characteristics of Soil Using Standard Effort (12,400 ft-lbf/ft³ (600 kN-m/m³))</i> 4. D2434-68(2006) <i>Standard Test Method for Permeability of Granular Soils (Constant Head)</i> 5. D2487-10 <i>Standard Classification of Soils for Engineering Purposes (Unified Soil Classification System)</i> 6. D4221-99(2005) <i>Standard Test Method for Dispersive Characteristics of Clay Soil by Double Hydrometer</i> 7. D4318-10 <i>Standard Test Methods for Liquid Limit, Plastic Limit, and Plasticity Index of Soils</i> 8. D4491-99a(2009) <i>Standard Test Methods for Water Permeability of Geotextiles by Permittivity</i> 9. D4533-04(2009) <i>Standard Test Method for Trapezoid Tearing Strength of Geotextiles</i> 10. D4632-08 <i>Standard Test Method for Grab Breaking Load and Elongation of Geotextiles</i> 11. D4751-04 <i>Standard Test Method for Determining Apparent Opening Size of a Geotextile</i> 12. D4833-07 <i>Standard Test Method for Index Puncture Resistance of Geotextiles, Geomembranes, and Related Products</i> 13. D5084-03 <i>Standard Test Methods for Measurement of Hydraulic Conductivity of Saturated Porous Materials Using a Flexible Wall Permeameter</i> 14. D5101-01(2006) <i>Standard Test Method for Measuring the Soil-Geotextile System Clogging Potential by the Gradient Ratio</i> 15. D5819-05 <i>Standard Guide for Selecting Test Methods for Experimental Evaluation of Geosynthetic Durability</i> 16. D6684-04 <i>Standard Specification for the Materials and Manufacture of Articulating Concrete Block (ACB) Revetment Systems</i> 17. D6884-03 <i>Standard of Practice for the Installation of Articulating Concrete Block (ACB) Revetment Systems</i> 18. D7276-08 <i>Standard Guide for Analysis and Interpretation of Test Data for Articulating Concrete Block (ACB) Revetment Systems in Open Channel Flow</i>

Hydraulics	ACB Design	Filtration	Reference
			<p>19. D7277-08 <i>Standard Test Method for Performance Testing of Articulating Concrete Block (ACB) Revetment Systems for Hydraulic Stability in Open Channel Flow</i></p> <p>ASTM standards summary can be previewed and the standard ordered through the ASTM web site at www.astm.org.</p>
Y			<p>20. Chow, V.T. <i>Open-Channel Hydraulics</i>. McGraw-Hill, New York, 1959.</p> <p>This famous textbook has been the definitive reference in open channel hydraulics since the time it was published. It was reissued in 1988 in response to a high demand after discontinued printing. The textbook is a good reference for any design professional working in open channel hydraulics, including erosion control and ACB design.</p> <p>Open-Channel Hydraulics covers a wide range of topics related to ACB design, including evaluation of shear stress, uniform flow, hydraulic backwater profiles, flow over spillways, hydraulic jumps, and flow in meandering channels. The reasons for its popularity probably include the broad range of topics and the fact that the textbook provides a useful balance between theory and application.</p>
	Y		<p>21. Clopper, P.E. <i>Hydraulic Stability of Articulated Concrete Block Revetment Systems During Overtopping Flow</i>, Technical Report FHWA RD-89 199. Federal Highway Administration, Washington, D.C., 1989.</p> <p>This document summarizes findings from full-scale laboratory testing of five proprietary ACB systems. The research was conducted as a follow up study from FHWA (1988) testing to provide a more comprehensive understanding of ACB performance. The goal of the testing was to define hydraulic processes causing ACB failure and isolate the hydraulic conditions at failure for each system. A secondary goal of the testing was to develop preliminary design guidelines for protection of embankments against erosion. The research conducted for this document has become the industry standard practice and set the starting point for continued research and development by ACB manufacturers.</p>
	Y		<p>22. Clopper, P.E., <i>Protecting Embankment Dams with Concrete Block Systems</i>. Hydro Review, April, 1991.</p> <p>The article represents the first time the factor of safety equations, as applied to ACB system, were published in a peer-reviewed journal. This document provides a good background and history of concrete block testing programs. Particular emphasis has been placed on research conducted by Simons, Li & Associates, Inc. that evaluated a number of methods for protecting embankments from erosion caused by overtopping flow. From this research a method was developed</p>

Hydraulics	ACB Design	Filtration	Reference
			<p>for assessing the stability of block systems under field hydraulic conditions. A thorough explanation introduces the resulting method referred to as the "factor of safety" procedure. This procedure has been adapted from previous research on the stability of riprap. Application of the factor of safety method is illustrated through a design example.</p>
	Y		<p>23. Clopper, P.E. And Y. Chen, <i>Minimizing Embankment Damage During Overtopping Flow</i>, Technical Report FHWA RD-88 181. Federal Highway Administration, Washington, D.C., 1988.</p> <p>This document provides a discussion and background literature review on the mechanics of overtopping flow (steep slope, high velocity conditions) and summarizes findings from full scale tests of bare soil, gabion, geosynthetics, soil cement, asphalt, cellular confinement systems, and ACB system on a 6 foot high earthen test embankment. The FHWA and the Bureau of Reclamation sponsored the research to provide pilot testing of each of the systems so that their performance and feasibility could be evaluated for field applications. Since the research was so broad in scope, the document does not provide substantial information related to ACB performance; however, it does define some of the observed failure mechanisms. A broad range of performance was observed between the three proprietary ACB systems that were tested, indicating the need for further research and development of the technology.</p>
Y	Y	Y	<p>24. Escarameia, M., <i>River and Channel Revetments: A Design Manual</i>. Thomas Telford Ltd., Heron Quay, London, 1988.</p> <p>Escarameia begins with background information including geotechnical factors affecting bank stability and the modes of bank failure most common in river engineering. A concise section on geotechnical stability addresses soil characteristics and applicable geotechnical parameters.</p> <p>The design manual identifies common revetment types and design equations for each, including ACB systems. Escarameia separates the discussion of block revetments into two sections: interlocking blocks and cabled blocks, and provides design equations for both. Parameters for these two design equations differ. Additional parameters included with the cabled block design equation include porosity of the revetment, water depth, and a slope factor. These two design equations determine required thickness only. The equations are empirical in form and very simple to apply. However, given the large variability in block performance observed in laboratory testing, the equations may not be suitable for all ACB systems. The manual does provide useful information related to the suitability of each block type to various applications.</p> <p>As an indication of the relative importance of bedding component design within the overall framework of revetment design, an individual Chapter entitled, "Use of granular filters and geotextiles," is included in this manual. The provided flowchart for filter design can be used to compare/contrast with the design steps</p>

Hydraulics	ACB Design	Filtration	Reference
			recommended in this design manual. The explanation of geotextile types is brief yet very informative and useful. Also, provided are several examples of situations where drainage layers are not advisable. In summary, Escarameia provides a compact presentation on filter design that is to the point and easy to follow.
Y	Y	Y	<p>25. Harris County Flood Control District, Harris County, Texas. <i>Design Manual for Articulating Concrete Block Systems, 2001.</i></p> <p>Ayres Associates prepared this design manual for The Harris County Flood District and it was the base for the first and the current edition of NCMA's Design Manual for Articulated Concrete Block. The manual was the first document that addressed some of the design issues and constructions of ACB systems.</p>
Y	Y	Y	<p>26. Hewlett, H.W.M., L.A. Boorman, and M.E. Bramley, <i>Design Of Grassed Waterways. Construction Industry Research and Information Association, London, 1987.</i></p> <p>This manual addresses a number of issues relating to grassed waterway design. Methods to reinforce grassed waterways are outlined and basic channel design is reviewed. Within the erosion resistance section, a recommendation is made to use a 2-dimensional woven fabric when the channel design process specifies a geotextile underlayer. A lower limit on the geotextile opening size of $O_{90} > 0.5$ mm is recommended here as well. Several field and laboratory experiences with erosion resistance reinforcement systems are reviewed within the ACB Design Manual.</p>
		Y	<p>27. Industrial Fabrics Association International, "2010 Specifiers Guide." <i>Geotechnical Fabrics Report, v. 27, No. 6, December, 2009.</i></p> <p>This guide is a special edition of the trade journal "Geotechnical Fabrics Report." It is updated annually, and provides tables of values for various physical properties of geotextiles. Tables are organized by manufacturer and product name (or alphanumeric acronym), and include most geotextiles typically specified for use in conjunction with articulating concrete block revetment systems.</p> <p>http://www.ifai.com</p>
Y	Y		<p>28. Julien, P.Y., <i>Erosion and Sedimentation. Cambridge University Press, Cambridge, UK, 1995.</i></p> <p>This sediment transport textbook is referenced because it provides the most general form of the factor of safety equations (i.e., steep slope in both longitudinal and lateral directions). The equations presented in the text are formulated for riprap design, and therefore can not be used to replace this design manual as an</p>

Hydraulics	ACB Design	Filtration	Reference
			<p>ACB design reference. The text is an important reference for subjects related to hydraulics and sediment transport. In particular, Julien's book gives an excellent presentation of turbulent velocity profiles and incipient motion analysis, both subjects pertinent to erosion control applications.</p>
		Y	<p>29. Koerner, Robert M., <i>Designing with Geosynthetics</i>, 5th edition. Prentice Hall, Upper Saddle River, New Jersey, 2005.</p> <p>Koerner presents a thorough coverage of geosynthetic design. Individual Chapters are devoted to designing with geotextiles, geogrids, geomembranes, geosynthetic clay liners, geopipes, and geocomposites. Specifically for purposes of design with geotextiles, Koerner details the functions and mechanisms of geotextiles as well as their properties and related test methods. A section addressing geotextile design for filtration proves somewhat useful although the applicable example problem is of a geotextile below riprap used as a coastal inlet protection. The description and analysis of geotextile property test methods is the strength of this reference. The soil retention function of geotextiles presented here parallels the method chosen for the HCFCF design manual.</p>
Y			<p>30. Lagasse, P.F., J.D. Schall, and E.V. Richardson, <i>Stream Stability At Highway Structures</i>, 3rd edition. Hydraulic Engineering Circular No. 20. Federal Highway Administration, Washington, D.C., 2001.</p> <p>This FHWA publication is most often referred to as HEC-20. The document provides background and methodology for stream reconnaissance and restoration projects. HEC-20 uses a multi-disciplinary approach including methods from geomorphology, sedimentology, hydrology, and hydraulics.</p> <p>An excellent feature of HEC-20 is that it is written for a broad range of audiences; it provides sufficient background for general planning, technical analysis, and design. It presents quantitative procedures for assessing local scour at piers, local scour at abutments, contraction scour, and long term degradation scour. The document suggests a three level approach to stream analysis/restoration projects that is systematic and general enough to apply to most projects. To date, HEC-20 is the most comprehensive and applied document related to stream reconnaissance and restoration projects.</p>

Hydraulics	ACB Design	Filtration	Reference
Y	Y		<p>31. Lagasse, P.F., P.E. Clopper, J.E. Pagan-Ortiz, L.W. Zevenbergen, L.A. Arneson, J.D. Schall, and L.G. Girard, Bridge Scour and Stream Instability Countermeasures: Experience, Selection, and Design Guidance - 3rd Edition. Hydraulic Engineering Circular No. 23. Federal Highway Administration, Washington, D.C., 2009.</p> <p>This FHWA publication is most often referred to as HEC-23. The document provides guidance for scour countermeasure designs at bridge crossings. HEC-23 was developed in response to the recognized need for FHWA support to design professionals related to scour countermeasures. Included is a countermeasure matrix that provides tabular information related to scour type and river environment suitability. The matrix also provides states where each countermeasure has been used successfully.</p> <p>HEC-23 provides specific design guidance for ACB systems that is similar to that presented in this document. However, this design manual is much more comprehensive and the design procedure presented here uses a more general set of equations. The 3rd edition of HEC-23 presents the Factor of Safety design equations for hydraulic stability of ACB systems that are identical to those presented in this manual.</p>
		Y	<p>32. Luettich, Scott M., Geotextile Filter Design Manual. Nicolon Mirafi Group, 1991.</p> <p>This design manual was prepared for the Nicolon Corporation by Luettich and reviewed by Dr. Robert C. Bachus and Dr. Jean-Pierre Giroud of GeoSyntec Consultants. The document closely follows a similarly titled article, "Geotextile Filter Design Guide", authored by the three individuals just mentioned, that appeared in the "Journal of Geotextiles and Geomembranes" in 1992. The manual covers many of the same topics and procedures as those presented in the HCFCD Criteria Manual bedding section. A good overview of the filtration processes associated with bedding components is presented. A step by step design procedure shows in detail the process for selecting an appropriate geotextile. Many topics relating to geotextile application design are briefly introduced and references for further information are provided. A number of design examples are included addressing a broad range of applications.</p>
Y			<p>33. Richardson, E.V. and S.R. Davis, Evaluating Scour At Bridges, 4th edition. Hydraulic Engineering Circular No. 18. Federal Highway Administration, Washington, D.C., 2001.</p> <p>This FHWA publication is most often referred to as HEC-18. The document provides guidelines for estimating scour at riverine and tidal bridges under hydraulic loading.</p>

Hydraulics	ACB Design	Filtration	Reference
			<p>HEC-18 presents two major classifications for scour: live-bed and clear water (indicating if sediment is being transported into the subject reach). Scour is also classified into three sub-types: contraction scour, pier scour, and degradation. In terms of ACB design, the scour of greatest interest is contraction scour and degradation. These variables need to be estimated when considering toe-down depth of the ACB revetment, as discussed in Sections C.3 and C.4.5.</p>
	Y		<p>34. Stevens, M.A. and D.B. Simons, “Stability Analysis For Coarse Granular Material On Slopes”. <i>River Mechanics</i>, Shen, H.W. (ed.), Fort Collins, Colorado, 1971.</p> <p>This document provides background information and development of the factor of safety design procedure. Stevens is the original developer/inventor of the design procedure for stability analysis using the moment balance approach. The document provides thorough insight into the development of the factor of safety equations; however, it is of limited use for ACB design purposes because the original equations are not tailored to analysis of blocks of known geometric dimensions.</p>
		Y	<p>35. Terzaghi, K., G. Mesri, and R.B. Peck, <i>Soil Mechanics In Engineering Practice</i>, 3rd edition. John Wiley & Sons, New York, 1996.</p> <p>This widely used and renowned textbook covers in great detail many of the soil mechanic topics critical to the field of civil engineering. Of particular importance to filter design are Articles One through Nine devoted to the index properties of soils and several articles included within Chapter 3 (permeability of soils, and particle migration and erosion). The Terzaghi rules used to determine the appropriate grain size of granular filter material are presented and briefly explained. These are the same rules used to design granular bedding components as presented within the HCFCD Design Manual. This text is particularly useful at providing definitions and explanations of the background soil information required by the bedding component design procedure.</p>
Y			<p>36. United States Army Corps of Engineers, <i>RMA2 Version 4.5</i>. USACE Waterways Experiment Station, Vicksburg, Mississippi, 2008.</p> <p>RMA2 is a sophisticated 2-dimensional model for free surface flow applications. RMA2 is a two-dimensional, depth-averaged finite element hydrodynamic numerical model. RMA2 solves the 2-dimensional version of the momentum and continuity equations at each node in a finite element mesh to calculate depth and velocity. The program is limited to sub-critical flow and longitudinal bed slopes less than 10 percent. Time dependent wind fields can also be added to the model as a boundary condition. RMA2 was originally developed by Resource Management Associates but is currently maintained by Waterways Experiment Station. The program itself does not provide</p>

Hydraulics	ACB Design	Filtration	Reference
			<p>editing utilities for the input file or a post processor for viewing model results. The most efficient way to develop the model and interpret results is using Surface-Water Modeling System (SMS) developed and supported by the Aquaveo, LLC of Provo, Utah. SMS is a pre- and post-processor that can be used to develop the finite element mesh geometry and boundary condition/run control file and view the model solution using several graphical tools. The RMA-2 source code, program, and manuals can be downloaded from the Aquaveo LLC web site:</p> <p style="text-align: center;">http://www.aquaveo.com</p> <p>The SMS program is not free but can be purchased at the above web address.</p>
Y			<p>37. United States Army Corps of Engineers, <i>HEC-RAS Version 4.1</i>. USACE Hydrologic Engineering Center, Davis, CA, January 2010.</p> <p>This is a widely used software package for 1-dimensional hydraulic modeling of open channel flow. A feature that makes HEC-RAS suitable for ACB design is that it will provide a horizontal velocity distribution at a cross section for a specified number of intervals that is based on the conveyance of each interval. However, this procedure can not replace 2-dimensional modeling for complex systems because the velocity distribution is not based on principals of momentum. The unsteady flow feature of HEC-RAS will make it suitable for tidal applications, where time dependent tide elevations can be used as a boundary condition. The HEC-RAS program and manuals are available free of charge from the HEC web site:</p> <p style="text-align: center;">http://www.wrc-hec.usace.army.mil/</p>
		Y	<p>38. Wilson-Fahmy, R.F., G.R. Koerner, and R.M. Koerner (1996). “Geotextile Filter Critique”. <i>Recent Developments in Geotextile Filters and Prefabricated Drainage Geocomposites</i>, ASTM STP 1281, Shobha K. and L. David Suits, Eds., American Society for Testing and Materials, 1996.</p> <p>This paper compares data collected from exhumed highway drainage field sites with existing geotextile design criteria for permeability, soil retention, and long term performance (clogging). The purpose here is to verify current design practices with actual in-field performance. The exhumed sites were each given a letter grade based on a visual assessment of their performance. This rating is followed by a review of the three primary requirements of geotextile filter design. Each of the specific design criteria widely in use (permeability, soil retention, and long term performance) are then presented in tabular form. These design criteria are assessed through comparison with actual in-field performance. The authors conclude by recommending a set of design criteria based upon the results of the comparison. This paper presents a very good summary of the current design methods in practice and provides some useful insight into observed behavior of geotextiles under actual field conditions.</p>

Hydraulics	ACB Design	Filtration	Reference
	Y	Y	<p>39. Lipscomb, C.M, C.I. Thornton, S.R. Abt, and J. R. Leech. “Performance of Articulated Concrete Blocks in Vegetated and Un-vegetated Conditions”</p> <p>This paper summarizes the research conducted by the U.S. Army Corps of Engineers investigating the performance of ACB system vegetated and un-vegetated showing an increase in the allowable shear stress of 41% when vegetated.</p>
	Y	Y	<p>40. Hunt, W.F., Collins, K.A., Hathaway, J.M. “Hydrologic and Water Quality Evaluation of Four Permeable Pavements in North Carolina, USA”</p> <p>This paper summarizes the research conducted on permeable pavement parking lot in eastern North Carolina consisting of four types of permeable pavement and standard asphalt. The research examined hydrologic differences in pavement surface runoff volumes, total outflow volumes, peak flow rates, and time to peak, and water quality concentrations.</p>
	Y	Y	<p>41. Kirkpatrick, R., Campbell, R, Smyth, J., Murtagh, J., Knapton, J. “Improvement Of Water Quality By Coarse Graded Aggregates In Permeable Pavements”</p> <p>The paper summarizes a research completed in Ireland to investigate the ability of permeable pavements to remove heavy metals and hydrocarbons from industrial water.</p>

APPENDIX A: DESIGN EQUATIONS – SI UNITS

A.1 The average cross-section shear stress:

$$\tau_0 = \gamma R S_f \quad (\text{Eqn. 2.1})$$

where:

τ_0	=	Cross-section-averaged shear stress, Pa
γ	=	Unit weight of water, 9,810 N/m ³
R	=	Hydraulic radius, m
S_f	=	Bed slope, m/m

A.2 The drag force on the block:

$$F'_D = 1/2 \cdot C_D (\Delta Z) b \rho V^2 \quad (\text{Eqn. 2.2})$$

where:

F'_D	=	Drag force due to block protrusion, N
C_D	=	Drag coefficient ($C_D \approx 1.0$)
ΔZ	=	Height of protrusion, m
b	=	Block width perpendicular to flow, m
ρ	=	Density of water, 1,000 kg/m ³
V	=	Velocity, m/s

A.3 Hydraulic Stability Equation for the ACB block:

$$\ell_2 W_{s2} = \ell_1 W_{s1} + \ell_3 (F_D + F'_D) + \ell_4 (F_L + F'_L) \quad (\text{Eqn. 4.1})$$

See Figure 4.1 for nomenclature.

A.4 Critical Shear Stress extrapolation from a steeper bed slope to that of a shallower bed slope for the same ACB system:

$$\tau_{C\theta U} = \tau_{C\theta T} \cdot \left(\frac{\ell_2 \cos \theta_U - \ell_1 \sin \theta_U}{\ell_2 \cos \theta_T - \ell_1 \sin \theta_T} \right) \quad (\text{Eqn. 4.2})$$

where:

$\tau_{C\theta U}$	=	Critical shear stress for untested bed slope, Pa
$\tau_{C\theta T}$	=	Critical shear stress for tested bed slope, Pa
θ_U	=	Untested bed slope (degrees) Where θ_U less than or equal to θ_T ; and where design velocity (V_{des}) less than or equal to the test Velocity (V_{max})
θ_T	=	Tested bed slope (degrees)
ℓ_x	=	Moment arms, m; Refer to Figure 4.4.

Note that the moment arms used in this equation should apply to the orientation of the block during testing and are not necessarily the same as those suggested later in this document for design.

A.5 Critical Shear Stress interpolation from one block thickness to another within the same family:

$$\tau_{CU} = \tau_{CT} \cdot \left(\frac{W_{SU} l_{2U}}{W_{ST} l_{2T}} \cdot \frac{l_{3T} + l_{4T}}{l_{3U} + l_{4U}} \right) \quad (\text{Eqn. 4.3})$$

Note: Extrapolated critical shear stress, τ_{CU} , is only applicable when considering an untested block thickness greater than that of the tested block thickness.

where:

τ_{CU}	=	Critical shear stress for untested block, Pa
τ_{CT}	=	Critical shear stress for tested block, Pa
W_{SU} and W_{ST}	=	Submerged weight of untested and tested blocks, N
l_{XU} and l_{XT}	=	Moment arms of untested and tested blocks, m

A.6 Factor of Safety of the ACB block:

$$SF = \frac{l_2 W_S a_\theta}{l_1 W_S \sqrt{1 - a_\theta^2} \cos \beta + l_3 F_D \cos \delta + l_4 F_L + l_3 F'_D \cos \delta + l_4 F'_L} \quad (\text{Eqn. 4.4})$$

The nomenclature, forces, dimensions, and angles in the equation for SF are presented in Figure 4.3.

A.7 Design Equations for ACB Systems – SI Units

$SF = \frac{(\ell_2 / \ell_1) a_\theta}{\sqrt{1 - a_\theta^2} \cos \beta + \eta_1 (\ell_2 / \ell_1) + \frac{(\ell_3 F'_D \cos \delta + \ell_4 F'_L)}{\ell_1 W_S}}$	4.5b	a_θ = Projection of W_S into subgrade beneath block b = Block width, m F'_D & F'_L = additional drag and lift forces, N P_x = Block moment arms (m) S_C = Specific gravity of concrete (assume 2.1) SF = Calculated factor of safety V_{des} = Design velocity, m/s (V_{des} less than or equal to V_{rest} or V_{max}) V_{max} = Maximum tested Velocity, m/s W = Weight of block, N W_S = Submerged weight of block, N ΔZ = Height of block protrusion above ACB matrix, m β = Angle of block projection from downward direction, once in motion δ = Angle between drag force and block motion η_0 = Stability number for a horizontal surface η_1 = Stability number for a sloped surface θ = Angle between side slope projection of W_S and the vertical θ_0 = Channel bed slope (degrees or radians) (less than or equal to test bed slope) θ_1 = Channel side slope (degrees or radians) Note - the equations cannot be solved for $\theta_1 = 0$ (i.e., division by 0); therefore, a negligible side slope must be entered for the case of $\theta_1 = 0$. ρ = Mass density of water, 1,000 kg / m ³ τ_C = Critical shear stress for block on a horizontal surface, Pa τ_{des} = Design shear stress, Pa
$\delta + \beta + \theta = 90^\circ$ or $\pi/2$ radians	4.6b	
$\eta_1 = \left(\frac{\ell_4 / \ell_3 + \sin(\theta_0 + \theta + \beta)}{\ell_4 / \ell_3 + 1} \right) \eta_0$	4.7b	
$\beta = \arctan \left(\frac{\cos(\theta_0 + \theta)}{(\ell_4 / \ell_3 + 1) \frac{\sqrt{1 - a_\theta^2}}{\eta_0 (\ell_2 / \ell_1)} + \sin(\theta_0 + \theta)} \right)$	4.8b	
$\theta = \arctan \left(\frac{\sin \theta_0 \cdot \cos \theta_1}{\sin \theta_1 \cdot \cos \theta_0} \right) = \arctan \left(\frac{\tan \theta_0}{\tan \theta_1} \right)$	4.9b	
$a_\theta = \sqrt{\cos^2 \theta_1 - \sin^2 \theta_0}$	4.10b	
$F'_L = F'_D = 0.5 \cdot (\Delta Z) b \rho V_{des}^2$	4.11b	
$\eta_0 = \frac{\tau_{des}}{\tau_C}$	4.12b	
$W_S = W \cdot \left(\frac{S_C - 1}{S_C} \right)$	4.13b	

A.8 Maximum shear stress:

$$\tau_{\max} = \tau_0 \cdot \left(\frac{V_{\text{des}}}{V_{\text{avg}}} \right)^2 \quad (\text{Eqn. 4.14})$$

where:

τ_{\max}	=	Maximum shear stress on the designed section, Pa
τ_0	=	Cross-section-averaged shear stress, Pa
V_{des}	=	Design velocity on the designed section, m/s
V_{avg}	=	Average velocity on the designed section, m/s

A.9 Permeability of soil

$$K_s = 1.958 \times 10^6 \frac{\phi^3}{(1-\phi)^2} \left(\frac{1}{49 \left(\sum_{n=1}^N \frac{P_n}{d_n} \right)^2} \right) \quad (\text{Eqn. 5.1})$$

where:

K_s	=	Soil permeability, cm/s
ϕ	=	Dimensionless soil porosity determined from Equation 5.2 or Table 5.1
P	=	Percentage of material in the distribution between adjacent particle sizes
d	=	Geometric mean of adjacent particle sizes in the distribution, mm
N	=	Number of intervals between adjacent particle sizes

A.10 Porosity of soil:

$$\phi = 1 - \left(\frac{C}{100} \cdot \frac{\gamma_d}{25.99 \text{ kN/m}^3} \right) \quad (\text{Eqn. 5.2})$$

where:

ϕ	=	Soil porosity (dimensionless)
C	=	Soil compaction in percent of Standard Proctor Density (90 to 100)
γ_d	=	Maximum dry unit weight of the soil at 100 percent of Standard Proctor Density, kN/m^3

A.11 Uniformity Coefficient, C_u :

$$C_u = \frac{d_{60}}{d_{10}} \quad (\text{Eqn. 5.3})$$

where:

d_x	=	Particle size of which X percent is smaller
-------	---	---

A.12 Geotextile Permeability Criterion:

$$K_g \geq 10K_s \quad (\text{Eqn. 5.4})$$

where:

K_g = Permeability of the geotextile, cm/s
 K_s = Permeability of the base soil or granular filter, cm/s

Conversion Table

Inch-Pound	To	Metric
1 inch (in.)	=	25.4 millimeters (mm)
1 foot (ft)	=	0.3048 meters (m)
1 yard (yd)	=	0.9144 meters (m)
1 square foot (ft ²)	=	0.0929 square meters (m ²)
1 square yard (yd ²)	=	0.8361 square meters (m ²)
1 ounce (oz)	=	28.35 grams (gm)
1 pound (lb)	=	0.4536 kilogram (kg)
1 pound (force) (lbs)	=	4.448 newtons (N)
1 pound/foot (lbs/ft)	=	0.0146 kilonewtons/meter (kN/m)
1 pound/inch (lbs/in.)	=	0.1751 kilonewtons/meter (kN/m)
1 pound/sq. inch (psi)	=	6.895 kilopascal (kPa)
1 pound/sq. foot (psf)	=	0.0479 kilopascal (kPa)
1 pound/cu. foot (pcf) (kN/m ³)	=	0.1571 kilonewtons/cubic meter

Metric	To	Inch-Pound
1 millimeter (mm)	=	0.03937 inches (in.)
1 meter (m)	=	39.37 inches (in.)
1 meter (m)	=	3.281 feet (ft)
1 square meter (m ²)	=	10.76 sq. feet (ft ²)
1 square meter (m ²)	=	1.196 sq. yards (yd ²)
1 gram (gm)	=	0.0353 ounces (oz)
1 kilogram (kg)	=	2.205 pounds (lb)
1 newton (N) (1 kg, force)	=	0.2248 pounds force (lb)
1 kilonewton/meter (kN/m)	=	68.5 pounds/foot (lbs/ft)
1 kilonewton/meter (kN/m)	=	5.71 pounds/inch (lbs/in.)
1 kilopascal (kPa)	=	0.145 pounds/sq. inch (psi)
1 kilopascal (kPa)	=	20.87 pounds/sq. foot (psf)
1 kilonewton/cubic meter (kN/m ³)	=	6.365 pounds/cu. foot (pcf)

Notations and Abbreviations

a_0	=	Projection of W_S into subgrade beneath block
b	=	Block width perpendicular to flow, ft (m)
C	=	Soil compaction in percent of Standard Proctor Density (90 to 100)
C_D	=	Drag coefficient ($C_D \approx 1.0$)
d	=	Geometric mean of adjacent particle sizes in the distribution (mm)
d_x	=	Particle size of which X percent is smaller
F_D'	=	Drag force due to block protrusion, lb (N)
F_L'	=	Lift force due to block protrusion, lb (N)
K_g	=	Permeability of the geotextile, cm/s
K_s	=	Permeability of the base soil or granular filter, cm/s
l_x	=	Moment arms, ft (m)
l_{XU} and l_{XT}	=	Moment arms of untested and tested blocks, ft (m)
N	=	Number of intervals between adjacent particle sizes
P	=	Percentage of material in the distribution between adjacent particle sizes
P.C.	=	Point of Curvature (beginning of the curve)
PI	=	Plasticity Index
P.T.	=	Point of Tangent (end of the curve)
P_x	=	Block moment arms (ft)
R	=	Hydraulic radius, ft (m)
S_C	=	Specific gravity of concrete (assume 2.1)
SF	=	Calculated factor of safety
S_f	=	Bed slope, ft/ft (m/m)
V	=	Velocity, ft/s (m/s)
V_{avg}	=	Average velocity on the designed section, ft/s (m/s)
V_{des}	=	Design velocity on the designed section, ft/s (m/s)
V_{test} or V_{max}	=	Test velocity determined during full-scale flume testing, ft/s (m/s)
W	=	Weight of block, lb (kg)
W_S	=	Submerged weight of block, lb (kg)
W_{SU} and W_{ST}	=	Submerged weight of untested and tested blocks, lbs (N)
β	=	Angle of block projection from downward direction, once in motion
γ	=	Unit weight of water, 62.4 lb/ft ³ (9,810 N/m ³)
γ_d	=	Dry unit weight of the soil at 100 percent of Standard Proctor Density lbs/ft ³ (kN/m ³)
ΔZ	=	Height of protrusion, ft (m)
ΔZ	=	Height of block protrusion above ACB matrix, ft (m)
δ	=	Angle between drag force and block motion
η_0	=	Stability number for a horizontal surface
η_1	=	Stability number for a sloped surface
θ	=	Angle between side slope projection of W_S and the vertical
θ_0	=	Channel bed slope (degrees or radians)
θ_1	=	Channel side slope (degrees or radians)
θ_T	=	Tested bed slope (degrees)
θ_U	=	Untested bed slope (degrees)
ρ	=	Density of water, 1.94 slugs/ft ³ (1,000 kg/m ³)
τ_C	=	Critical shear stress for block on a horizontal surface (lb/ft ²)
τ_{CT}	=	Critical shear stress for tested block, lb/ft ² (Pa)

τ_{CU}	=	Critical shear stress for untested block, lb/ft ² (Pa)
$\tau_{C\theta U}$	=	Critical shear stress for untested bed slope, lb/ft ² (Pa)
$\tau_{C\theta T}$	=	Critical shear stress for tested bed slope, lb/ft ² (Pa)
τ_{des}	=	Design shear stress, lb/ft ² (Pa)
τ_{max}	=	Maximum shear stress on the designed section, lb/ft ² (Pa)
τ_0	=	Cross-section-averaged shear stress, lb/ft ² (Pa)
ϕ	=	Soil porosity (dimensionless)

NATIONAL
CONCRETE MASONRY
ASSOCIATION